

INDUSTRIAL FLUID CONTROLS

CINCINNATI, OHIO 45246 (513)874-8499

dixonvalve.com

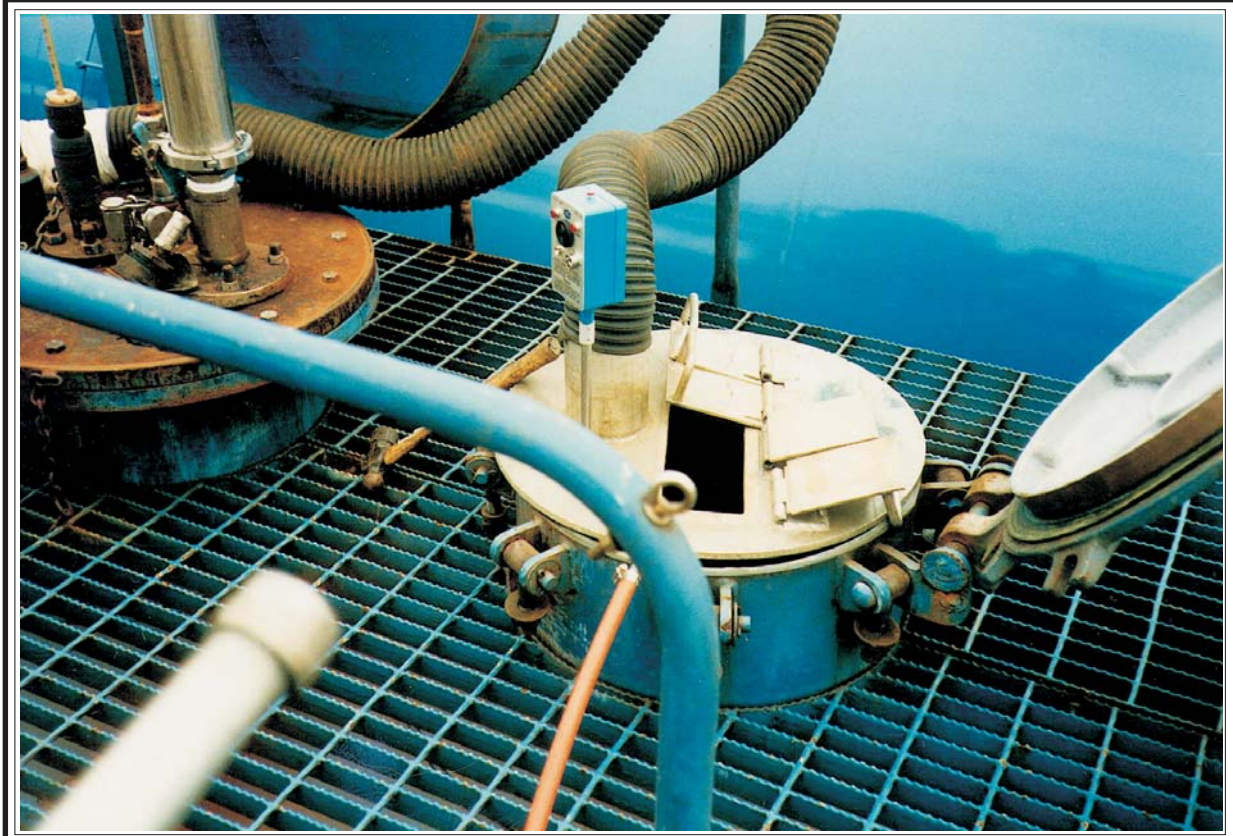

Manufacturers of liquid level controls for overflow prevention.

- Liquid terminal operations
- Field storage

**A Leader in Liquid Terminal Automation Controls.
Standard Products, Custom Designs and Applications.**

- Specifically designed for liquid terminal operation.
- Inherently safe for the most hazardous areas.
- Rugged *Phase-Shift* level sensor. No moving parts.
- Optional self-test feature permits testing entire system prior to loading.
- Graduated rod, laser engraved scale, up to 60" long.
- Adjustable insertion length, 1/2" NPT connection.
- Stainless Steel interlocking armor probe cable.
- Fail-Safe design. Trips on open or shorted cable or power failure.

Batch Loading and Overfill Protection, Tank Cars, Tank Trucks, Marine Barges, Open and Close Dome



Model A-100 OutalarmTM self-contained Battery operated alarm. Up to 2500 Hour battery life, high intensity visual and audible outputs, optional remote output.



SpillguardTM A-210 Automatic High Level Shutdown
Optional ground varification and tilt interlocks



SpillguardTM A-200 Automatic High Level Shutdown
Optional ground varification and tilt interlocks

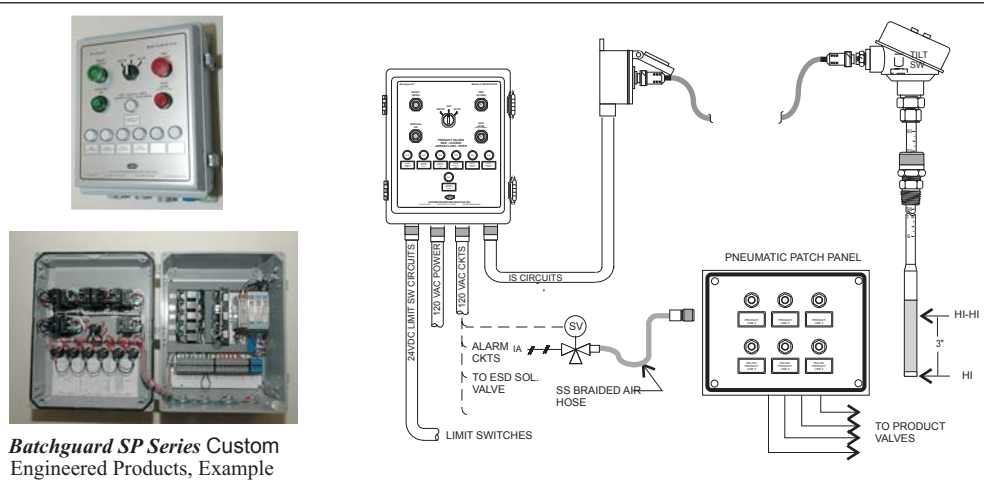

Batchguard SP Series Custom Engineered Products, Example

INDUSTRIAL FLUID CONTROLS

CINCINNATI, OHIO 45246 (513) 874-8499 dixonvalve.com

Model A-100 *Outalarm*TM Portable Battery Operated Liquid Level Alarm

- Various configurations
- Options
- Accessories



Manufacturers of liquid level controls for overfill prevention.

- Liquid terminal automation
- Field storage



OUTALARM™



BATTERY OPERATED
PORTABLE ULLAGE ALARM

MODEL A-100

SELF CONTAINED PORTABLE ULLAGE ALARM for use in loading *tank cars, tank trucks, barges, ships.* Prevent spills, personnel exposure, overloading. Suitable for open and closed dome loading.

FEATURES:

- Totally self contained - no wires, no tubing, no external power.
- Rugged weather and corrosion resistant construction.
- No moving parts, tip sensitive *phase shift™* digital capacitance sensor.
- Intrinsically safe design per ANSI/UL913 for Class I, Div 1 Groups A, B, C, & D Hazardous Areas.
- Requires no calibration or adjustment.
- Operates up to 2500 hours on single 9 V alkaline battery.
- Adjustable insertion length through standard 1/2" NPT fitting.
- High intensity audible and flashing visual outputs.
- Full hard graduated rod, laser engraved.
- Optional opto-isolated solid state contact output.
- Fail Safe continuous battery monitor, goes to alarm state on low battery.

SPECIFICATIONS:

- Activation point: 1/4" above liquid surface.
- Probe length: 2 ft. 3 ft. 4 ft. & 5 ft. standard. Custom and longer lengths available.
- Insertion length: 4" to max probe length.
- Battery current drain: <0.23 ma during standby, <50 ma in alarm state.
- Minimum dielectric constant 1.8
- Horn intensity: 101 db at 2 ft.
- Light output: 3 ea 3000 mcd high intensity flashing LED's.
- Wetted materials: 316 SS, Teflon™ Other materials available.
- Temperature range -14 to +250 Deg F
- Pressure rating - standard unit 50 psig. Consult factory for applications up to 300 psig.



SLIDING
GLAND
1/2" NPT

1/2" OD SHAFT
316 SS, 1/4"
GRADUATIONS

5/8" OD TIP
TEFLON

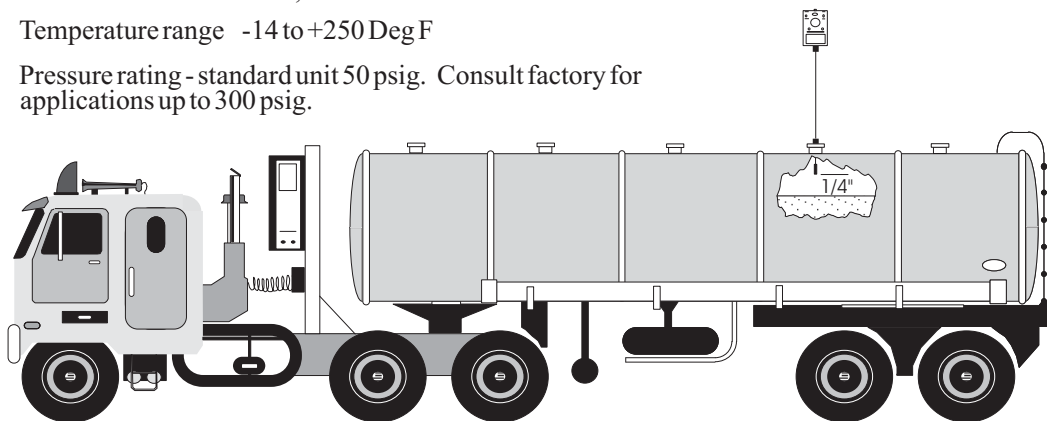

INDUSTRIAL FLUID CONTROLS

CINCINNATI, OHIO 45246 (513) 874-8499

dixonvalve.com

OUTALARMTM

OPERATING INSTRUCTIONS

MODEL A-100

1. Test unit by operating battery test. If the test light glows green the battery is ok. Replace battery with a fresh 9 v alkaline if the lamp flashes red..

Note: The A-100 features a continuous fail safe battery monitor. In the event that the battery voltage drops below the lower threshold voltage, the unit will go into alarm and remain so until turned off. While in the low battery alarm mode the battery test light will flash red.

2. Turn unit on by operating the toggle to the right. The protective ring has been provided to ensure that the toggle does not get accidentally bumped to the off position.
3. Test operation of alarm by letting the probe tip contact a liquid or firm object. The horn should activate and the alarm lights should flash. If the battery test light flashes red replace the battery.
4. Insert probe into vessel through a 1/2" NPT connection. Finger tight is adequate in most cases.
5. Adjust probe to proper outage and tighten the knurled nut. Again, finger tight should be adequate.
6. Alarm is now in operation.
7. Caution - loosen packing nut before moving rod up or down to prevent galling rod.

GENERAL COMMENTS:

1. The alarm activates when the probe tip is approximately 1/4" below the liquid surface, +/- 1/4" depending on the dielectric constant of the material being sensed. The response time is instantaneous.
2. Battery life is quite long. The current drain at standby conditions is less than 0.30 MA, and in the alarm mode the drain is approximately 40 MA. The capacity of a fresh alkaline battery is approximately 600 MA-hours. The new Ultralife U9VL Lithium battery can be safely used in this apparatus and meets the Intrinsic Safety requirement. Life expectancy of the lithium battery is approximately twice that of an alkaline battery with a somewhat louder horn output as a result of the battery's higher output voltage.



OUTALARM™



BATTERY OPERATED
PORTABLE ULLAGE ALARM

MODEL A100-HT325

SELF CONTAINED PORTABLE ULLAGE ALARM for use in loading *high temperature liquids up to 325F* Prevent spills, personnel exposure, overloading. Suitable for open and closed dome loading. *Tip sensitive Phase-Shift™ Capacitance Sensor* for conductive and non-conductive fluids.

FEATURES:

- Totally self contained - no wires, no tubing, no external power.
- Rugged weather and corrosion resistant construction.
- No moving parts, tip sensitive *phase shift™* digital capacitance sensor.
- Intrinsically safe design per ANSI/UL913 for Class I, Div 1 Groups A, B, C, & D Hazardous Areas.
- Requires no calibration or adjustment.
- Operates up to 2500 hours on single 9 V alkaline battery.
- Adjustable insertion length through standard 1/2" NPT fitting.
- High intensity audible and flashing visual outputs.
- Full hard graduated rod, laser engraved.
- Optional opto-isolated solid state contact output.
- Fail Safe continuous battery monitor, goes to alarm state on low battery.

SPECIFICATIONS:

- Activation point: 1/4" above liquid surface.
- Probe length: 2 ft. 3 ft. 4 ft. & 5 ft. standard. Custom and longer lengths available.
- Insertion length: 4" to max probe length.
- Battery current drain: <0.23 ma during standby, <50 ma in alarm state.
- Minimum dielectric constant 1.7
- Horn intensity: 101 db at 2 ft.
- Light output: 3 ea 3000 mcd high intensity flashing LED's.
- Wetted materials: 316 SS, Teflon™ Other materials available.
- Temperature range -14 to +325 Deg F
- Pressure rating - standard unit 50 psig. Consult factory for applications up to 300 psig.

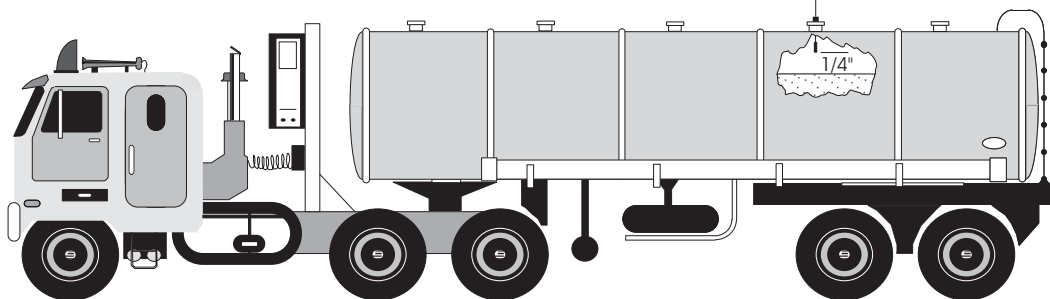

INDUSTRIAL FLUID CONTROLS

CINCINNATI, OHIO 45246 (513) 874-8499

dixonvalve.com



OUTALARMTM

OPERATING INSTRUCTIONS



MODEL A100-HT325

1. Test unit by operating battery test. If the test light glows green the battery is ok. Replace battery with a fresh 9 v alkaline if the lamp flashes red..

Note: The A-100 features a continuous fail safe battery monitor. In the event that the battery voltage drops below the lower threshold voltage, the unit will go into alarm and remain so until turned off. While in the low battery alarm mode the battery test light will flash red.

2. Turn unit on by operating the toggle to the right. The protective ring has been provided to ensure that the toggle does not get accidentally bumped to the off position.
3. Test operation of alarm by letting the probe tip contact a liquid or firm object. The horn should activate and the alarm lights should flash. If the battery test light flashes red replace the battery.
4. Insert probe into vessel through a 1/2" NPT connection. Finger tight is adequate in most cases.
5. Adjust probe to proper outage and tighten the knurled nut. Again, finger tight should be adequate.
6. Alarm is now in operation.
7. Caution - loosen packing nut before moving rod up or down to prevent galling rod.

GENERAL COMMENTS:

1. The alarm activates when the probe tip is approximately 1/4" below the liquid surface, +/- 1/4" depending on the dielectric constant of the material being sensed. The response time is instantaneous.
2. Battery life is quite long. The current drain at standby conditions is less than 0.25 MA, and in the alarm mode the drain is approximately 40 MA. The capacity of a fresh alkaline battery is approximately 600 MA-hours. The new Ultralife U9VL Lithium battery can be safely used in this apparatus and meets the Intrinsic Safety requirement. Life expectancy of the lithium battery is approximately twice that of an alkaline battery with a somewhat louder horn output as a result of the battery's higher output voltage.



OUTALARM™



BATTERY OPERATED

HIGH TEMPERATURE PORTABLE ULLAG ALARM MODEL A-100C

SELF CONTAINED PORTABLE ULLAGE ALARM. for use in loading *tank cars, tank trucks, barges, ships.* Prevent spills, personnel exposure, overloading. Suitable for open and closed dome loading. Conductivity sensor for conductive fluids.

FEATURES:

- Totally self contained - no wires, no tubing, no external power.
- Rugged weather and corrosion resistant construction.
- No moving parts, variable sensitivity conductivity sensor.
- Intrinsically safe design per ANSI/UL913 for Class I, Div 1 Groups A, B, C, & D Hazardous Areas.
- Requires no calibration or adjustment.
- Operates up to 5000 hours on single 9 V alkaline battery.
- Adjustable insertion length through standard 1/2" NPT fitting.
- High intensity audible and flashing visual outputs.
- Graduated rod, laser engraved.
- Optional opto-isolated solid state contact output.
- Fail Safe continuous battery monitor, goes to alarm state on low battery.

SPECIFICATIONS:

- Activation point: tip 1/2" below liquid surface.
- Sensor sensitivity adjustable from 0 - 500 k ohms. Nominal setting 200 kohms.
- Probe length: 2 ft. 3 ft. 4 ft. & 5 ft. standard. Custom and longer lengths available.
- Insertion length: 4" to max probe length.
- Battery current drain: <0.12 ma standby, <50 ma alarm state.
- Horn intensity: 100 db at 2 ft.
- Light output: 3 ea 3000 mcd high intensity flashing LED's.
- Wetted materials: 316 SS and teflon. Other materials available.
- Temperature range -50 to 500 Deg F standard.
- Pressure rating - standard unit 50 psig. Consult factory for applications up to 300 psig.

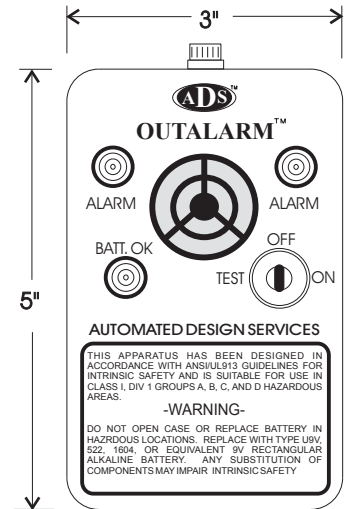

1/2" OD SHAFT
316 SS, LASER
ENGRAVED
SCALE

SLIDING
GLAND
1/2" NPT

← ACTIVATION
POINT

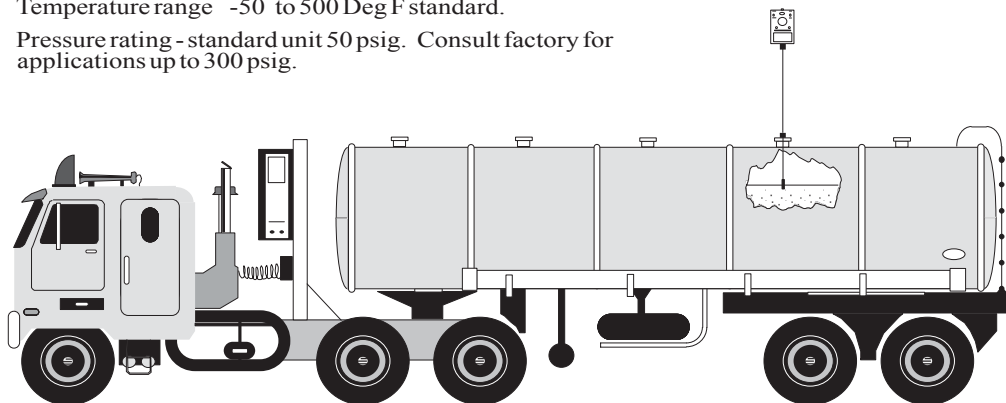

INDUSTRIAL FLUID CONTROLS

CINCINNATI, OHIO 45246 (513) 874-8499

dixonvalve.com



OUTALARM™

BATTERY OPERATED PORTABLE ULLAGE ALARM FOR CONDUCTIVE FLUIDS



The Right Connection®

MODEL A-100 CSS

SELF CONTAINED PORTABLE ULLAGE ALARM for use in loading tank cars, tank trucks and barges. Prevent spills, personnel exposure, overloading. Suitable for closed dome loading.

FEATURES:

- Totally self contained - no wires, no tubing, no external power.
- Rugged weather and corrosion resistant construction.
- No moving parts, conductivity sensor with integral splash shield
- Intrinsically safe design per ANSI/UL913 for Class I, Div 1 Groups A, B, C, & D Hazardous Areas.
- Requires no calibration or adjustment.
- Operates up to 5000 hours on single 9 V alkaline battery.
- Adjustable insertion length through standard 1/2" NPT fitting.
- High intensity audible and flashing visual outputs.
- Graduated rod, laser engraved.
- Optional opto-isolated solid state contact output.
- Fail Safe continuous battery monitor, goes to alarm state on low battery.

SPECIFICATIONS:

- Sensor sensitivity 200k ohms
- Probe length: 2 ft. 3 ft. 4 ft. & 5 ft. standard. Custom and longer lengths available.
- Insertion length: 4" to max probe length.
- Battery current drain: <0.12 ma during standby, <50 ma in alarm state.
- Horn intensity: 100 db at 2 ft.
- Light output: 3 ea 3000 mcd high intensity flashing LED's.
- Wetted materials: 316SS and Teflon .
- Temperature range -14 to +500 Deg F
- Pressure rating - standard unit 50 psig. Consult factory for applications up to 300 psig.

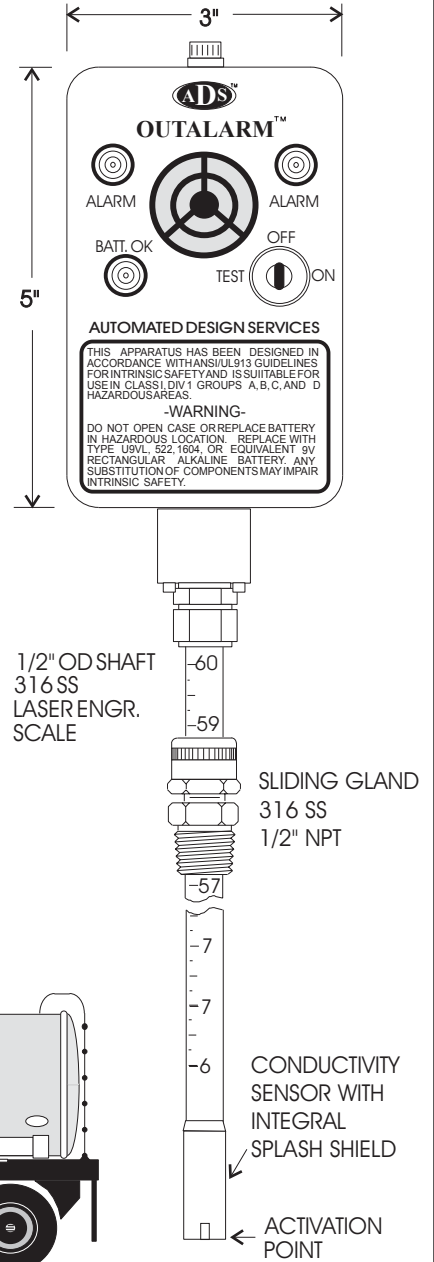
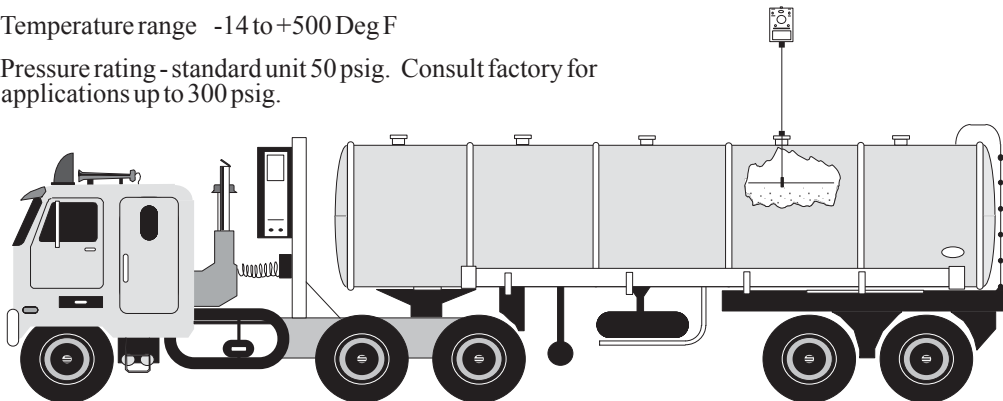

INDUSTRIAL FLUID CONTROLS

CINCINNATI, OHIO 45246 (513) 874-8499

dixonvalve.com



OUTALARMTM

OPERATING INSTRUCTIONS



MODEL A-100C/CSS

1. Test unit by operating battery test. If the test light glows green the battery is ok. Replace battery with a fresh 9 v alkaline if the lamp does not light.
Note: The A-100 features a continuous fail safe battery monitor. In the event that the battery voltage drops below the lower threshold voltage, the unit will go into alarm and remain so until turned off. While in the low battery alarm mode the battery test light will flash red.
2. Turn unit on by operating the toggle to the right. The protective ring has been provided to ensure that the toggle does not get accidentally bumped to the off position.
3. Test operation of alarm by letting the probe tip contact a sample of the liquid to be detected. The horn should activate and the alarm lights should flash. If the battery test light flashes red, replace battery with a fresh 9 V rectangular alkaline battery.
4. Insert probe into vessel through a 1/2" NPT connection. Finger tight is adequate in most cases.
5. Adjust probe to proper outage and tighten the knurled packing nut. Again, finger tight should be adequate.
6. Alarm is now in operation.
7. Caution - loosen packing nut before moving rod up or down to prevent galling rod.

GENERAL COMMENTS:

1. The alarm activates when the probe tip electrodes are bridged by a conductive fluid. The resistance at which activation occurs is factory set at 200 k ohms. Other sensitivities are available in the range of 0 to 500K ohms.
2. Battery life is quite long. The current drain at standby conditions is less than 0.14 MA, and in the alarm mode the drain is approximately 40 MA. The capacity of a fresh alkaline battery is approximately 600 MA-hours. The new Ultralife U9VL Lithium battery can be safely used in this apparatus and meets the Intrinsic Safety requirement. Life expectancy of the lithium battery is approximately twice that of an alkaline battery, with a somewhat louder horn output as a result of the battery's higher output voltage.



OUTALARM™

BATTERY OPERATED PORTABLE ULLAGE ALARM
FOR HYDROCHLORIC ACID SERVICE



The Right Connection®
MODEL A-100H

SELF CONTAINED PORTABLE ULLAGE ALARM. . . . for use in loading HCl into tank cars and tank trucks. Prevent spills, personnel exposure, overloading. Suitable for closed dome loading.

FEATURES:

- Totally self contained - no wires, no tubing, no external power.
- Rugged weather and corrosion resistant construction.
- No moving parts, conductivity sensor with integral splash shield
- Intrinsically safe design per ANSI/UL913 for Class I, Div 1 Groups A, B, C, & D Hazardous Areas.
- Requires no calibration or adjustment.
- Operates up to 5000 hours on single 9 V alkaline battery.
- Adjustable insertion length through standard 1/2" NPT fitting.
- High intensity audible and flashing visual outputs.
- Graduated rod, laser engraved.
- Optional opto-isolated solid state contact output.
- Fail Safe continuous battery monitor, goes to alarm state on low battery.

SPECIFICATIONS:

- Sensor sensitivity 200k ohms
- Probe length: 2 ft. 3 ft. 4 ft. & 5 ft. standard. Custom and longer lengths available.
- Insertion length: 4" to max probe length.
- Battery current drain: <0.12 ma during standby, <50 ma in alarm state.
- Horn intensity: 100 db at 2 ft.
- Light output: 3 ea 3000 mcd high intensity flashing LED's.
- Wetted materials: Hastelloy C-276 and Teflon .
- Temperature range -14 to +300 Deg F
- Pressure rating - standard unit 50 psig. Consult factory for applications up to 300 psig.



SLIDING GLAND
SOLID TEFLON
1/2" NPT

1/2" OD SHAFT
HAST C-276,
LASER ENGR.
SCALE

CONDUCTIVITY SENSOR WITH
INTEGRAL
SPASH SHIELD

← ACTIVATION
POINT

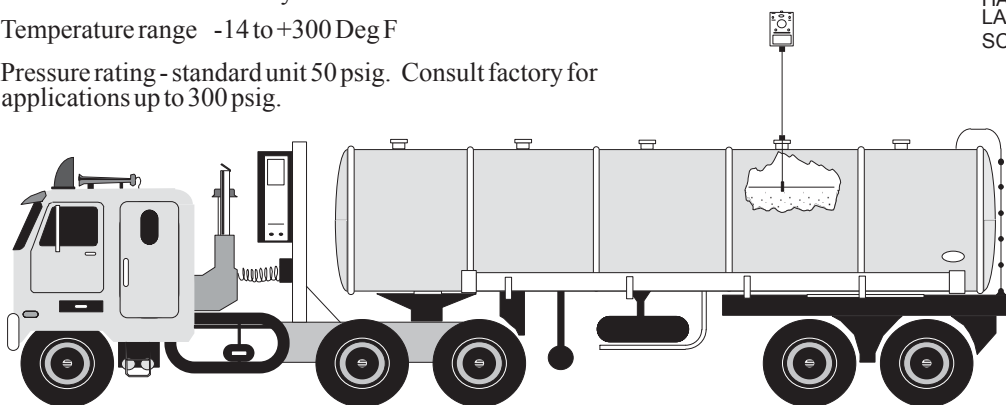

INDUSTRIAL FLUID CONTROLS

CINCINNATI, OHIO 45246 (513) 874-8499

dixonvalve.com



OUTALARMTM

OPERATING INSTRUCTIONS



MODEL A-100HCL

1. Test unit by operating battery test. If the test light glows green the battery is ok. Replace battery with a fresh 9 v alkaline if the lamp does not light.
Note: The A-100 features a continuous fail safe battery monitor. In the event that the battery voltage drops below the lower threshold voltage, the unit will go into alarm and remain so until turned off. While in the low battery alarm mode the battery test light will flash red.
2. Turn unit on by operating the toggle to the right. The protective ring has been provided to ensure that the toggle does not get accidentally bumped to the off position.
3. Test operation of alarm by letting the probe tip contact a sample of the liquid to be detected. The horn should activate and the alarm lights should flash. If the battery test light flashes red, replace battery with a fresh 9 V rectangular alkaline battery.
4. Insert probe into vessel through a 1/2" NPT connection. Finger tight is adequate in most cases.
5. Adjust probe to proper outage and tighten the knurled packing nut. Again, finger tight should be adequate.
6. Alarm is now in operation.
7. Caution - loosen packing nut before moving rod up or down to prevent galling rod.

GENERAL COMMENTS:

1. The alarm activates when the probe tip electrodes are bridged by a conductive fluid. The resistance at which activation occurs can be adjusted from 0 to 500K ohms. The nominal setting as shipped is 200K ohms. Adjustment is made via a 11 turn trim pot on the amplifier module inside the monitor. To change the setting connect a resistor with the desired resistance and adjust the trim pot until the monitor changes state.
2. Battery life is quite long. The current drain at standby conditions is less than 0.14 MA, and in the alarm mode the drain is approximately 40 MA. The capacity of a fresh alkaline battery is approximately 600 MA-hours. The new Ultralife U9VL Lithium battery can be safely used in this apparatus and meets the Intrinsic Safety requirement. Life expectancy of the lithium battery is approximately twice that of an alkaline battery, with a somewhat louder horn output as a result of the battery's higher output voltage.



OUTALARM™

BATTERY OPERATED
PORTABLE PRESSURE ALARM



MODEL A100 PRS Hy-Lo

SELF CONTAINED PORTABLE PRESSURE ALARM. For use in closed dome loading or unloading of *tank cars, tank trucks, barges, ships.* Prevent over or under pressurizing

FEATURES:

- Totally self contained - no wires, no tubing, no external power.
- Rugged weather and corrosion resistant construction.
- Dual set points. Can be configured to alarm on both low pressure decreasing and high pressure increasing over a range of full vacuum to 50 PSIA.
- Intrinsically safe design per ANSI/UL913 for Class I, Div 1 Groups A, B, C, & D Hazardous Areas.
- Operates over one year in standby mode on a single 9V alkaline battery.
- Adapts to a standard 1/4" NPT fitting.
- High intensity audible and flashing visual outputs.
- Optional opto-isolated solid state contact output.
- Fail Safe continuous battery monitor, goes to alarm state on low battery.

SPECIFICATIONS:

- Pressure range 0 - 50 psia adjustable. Higher ranges available.
- Process connection 1/8" and 1/4" male NPT
- Battery current drain: <0.50 MA during standby (1200 hr life), <50 ma in alarm state.
- Horn intensity: 101 db at 2 ft minimum.
- Light output: 3 ea 3000 mcd high intensity flashing LED's.
- Wetted parts all 316 SS welded construction
- Temperature range -40 to +180 Deg F ambient.
- Proof pressure standard unit 150 psia

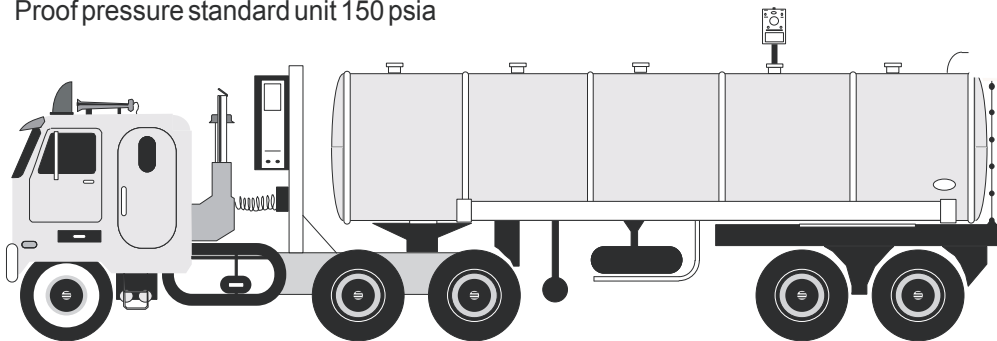

INDUSTRIAL FLUID CONTROLS

CINCINNATI, OHIO 45246 (513) 874-8499

dixonvalve.com



PRESSURE ALARM OPERATING INSTRUCTIONS



MODEL A100 PRS Hy-Lo

1. Test unit by operating battery test. If the test light glows green the battery is ok. Replace battery with a fresh 9 v alkaline if the lamp flashes red.
Note: The A-100 features a continuous fail safe battery monitor. In the event that the battery voltage drops below the lower threshold voltage, the unit will go into alarm and remain so until turned off. While in the low battery alarm mode the battery test light will flash red.
2. The unit is turned on by operating the toggle to the right. The protective ring has been provided to ensure that the toggle does not get accidentally bumped to the off position.
3. Connect pressure port to vessel through 1/4" NPT connection. Hand tight is adequate in most cases.
4. Turn the power switch on.
5. Alarm is now in operation.

NOTE

REFER TO PRESSURE SWITCH INSTRUCTION SHEET
BEFORE ATTEMPTING TO ADJUST PRESSURE SWITCH

GENERAL COMMENTS:

Battery life is quite long. The current drain at standby conditions is approx. 0.50 MA, and in the alarm mode the drain is approximately 40 MA. The capacity of a fresh alkaline battery is approximately 600 MA-hours. The new Ultralife U9VL Lithium battery can be safely used in this apparatus and meets the Intrinsic Safety requirement. Life expectancy of the lithium battery is approximately twice that of an alkaline battery with a somewhat louder horn output as a result of the battery's higher output voltage.

CALIBRATION PROCEDURE DUAL SET POINT ELECTRONIC PRESSURE SWITCH

MODEL NO.:	A300-19C050PA4K-2PT
CALIBRATION RANGE:	0 - 50 PSIA
OUTPUT:	NAMUR (LO < 1 MA, HI > 2 MA)
WETTED PARTS:	316 SS WELDED DIAPHRAGM
PROOF PRESSURE:	150 PSIA



LOCATION OF CALIBRATION
TRIM POTS, TOP VIEW

The electronic pressure switch can be calibrated either as a direct acting or reverse acting single point switch, or as a dual set-point switch that can alarm within or outside of a gap via the two calibration trim pots located at the top of the unit. The calibration procedures are as follow:

Trim pots are multi-turn (11 turns) with slip clutch at each end. When Setting to full CW or full CCW turn screw a minimum of 15 full turns in the appropriate direction. To access the trim pots remove the top fitting by first removing the single Phillips head screw then pulling out the fitting. There is sufficient slack in the wires to allow access to the trim pots.

DIRECT ACTING SINGLE POINT: (Output goes from low to high at the set-point on increasing pressure)

Set R-1 fully CCW.
Apply set pressure at the port.
adjust R-2 CW to raise set-point, or CCW to lower set-point.

REVERSE ACTING SINGLE POINT: (Output goes from high to low at the set-point on increasing pressure)

Set R-2 fully CW.
Apply set pressure at the port.
adjust R-1 CW to raise set-point, or CCW to lower set-point.

ALARM OUTSIDE OF A GAP: (Output goes high below a low pressure set-point or above a high pressure set-point)

Temporarily set R-2 fully CW.
Apply low set pressure at the port.
adjust R-1 until alarm goes on (output goes high), CW to raise/CCW to lower .
Raise set pressure to the high value (alarm will clear and output will go low).
Adust R-2 CCW until alarm goes back on (output goes high).



INDUSTRIAL FLUID CONTROLS
CINCINNATI, OHIO 45246 (513) 874-8499





OUTALARM™



The Right Connection®

BATTERY OPERATED
PORTABLE ULLAGE/PRESSURE ALARM

MODEL A-110

SELFCONTAINED PORTABLE ULLAGE/PRESSURE ALARM.... for use in loading *tank cars, tank trucks, barges, ships.* Prevent spills, personnel exposure, overloading, overpressure. Suitable for open and closed dome loading.

FEATURES:

- Totally self contained - no wires, no tubing, no external power.
- Rugged weather and corrosion resistant construction.
- No moving parts, non contact proximity level sensor.
- Intrinsically safe design per ANSI/UL913 for Class I, Div 1 Groups A, B, C, & D Hazardous Areas.
- Alarms on either high level or dual set-point high/low pressure.
- Operates up to 1000 hours on single 9 V alkaline battery.
- Adjustable insertion length through standard 1/2" NPT fitting.
- High intensity audible and flashing visual outputs.
- Graduated rod, laser engraved.
- Optional opto-isolated solid state contact output.
- Fail Safe continuous battery monitor, goes to alarm state on low battery.

SPECIFICATIONS:

- Level activation point: 1/4" above liquid surface. Pressure: user adjustable full vacuum to 50 psia, dual point. See calibration instructions.
- Probe length: 2 ft. 3 ft. 4 ft. & 5 ft. standard. Custom and longer lengths available.
- Insertion length: 4" to max probe length.
- Battery current drain: <0.60 ma standby, <50 ma alarm.
- Horn intensity: 101 db at 2 ft.
- Light output: 3 ea 3000 mcd high intensity flashing LED's.
- Wetted materials: 316 SS, Teflon™ Other materials available.
- Temperature range -14 to +212 Deg F
- Pressure rating - standard unit 50 psig.
- Pressure transducer proof pressure 150 psia.

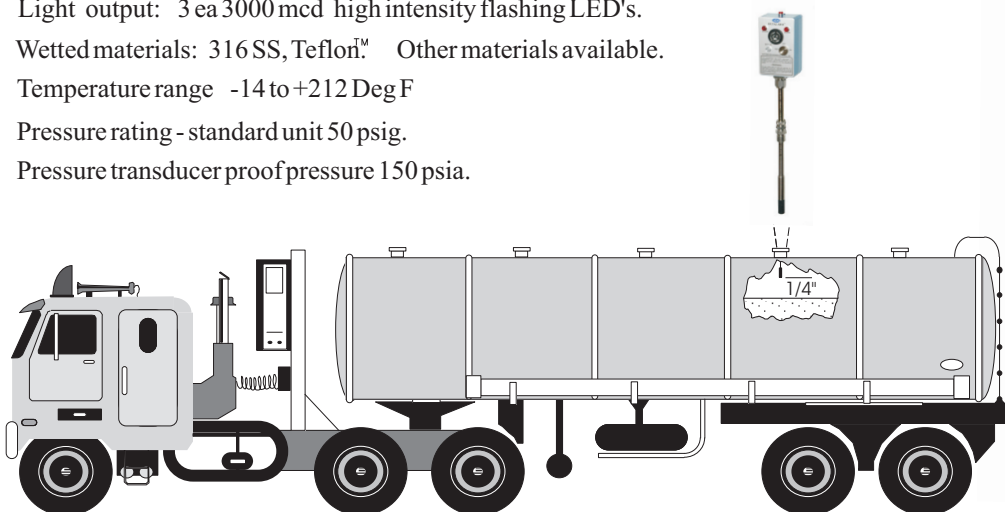

STANDARD
A-100 MONITOR



INDUSTRIAL FLUID CONTROLS

CINCINNATI, OHIO 45246 (513) 874-8499

dixonvalve.com

LEVEL/PRESSURE ALARM OPERATING INSTRUCTIONS

MODEL A-110

1. Test unit by operating battery test. If the test light glows green the battery is ok. Replace battery with a fresh 9 v alkaline if the lamp glows red

Note: The A-110 features a continuous fail safe battery monitor. In the event that the battery voltage drops below the lower threshold voltage, the unit will go into alarm and remain so until turned off. While in the low battery alarm mode the battery test light will flash red.

2. The unit is turned on by operating the toggle to the right. The protective ring has been provided to ensure that the toggle does not get accidentally bumped to the off position.
3. Test operation of the level alarm by letting the probe tip contact a liquid or firm object. The horn should activate and the alarm lights should flash. If the battery test light flashes red replace the battery. The pressure transducer can only be functionality tested by pressurization.
4. Insert probe into vessel through 1/2" NPT connection.. Finger tight is adequate in most cases.
5. Adjust probe to proper outage and tighten the knurled nut . Again, finger tight should be adequate.
6. Alarm is now in operation.
7. Caution - loosen packing nut before moving rod up or down to prevent galling rod.

- NOTE -

REFER TO PRESSURE TRANSDUCER INSTRUCTION SHEET
BEFORE ATTEMPTING TO ADJUST SETPOINTS

GENERAL COMMENTS:

Battery life is quite long. The current drain at standby conditions is approx. 0.6 MA, and in the alarm mode the drain is approximately 40 MA. The capacity of a fresh alkaline battery is approximately 600 MA-hours.

The new Ultralife U9VL Lithium battery can be safely used in this apparatus and meets the Intrinsic Safety requirement. Life expectancy of the lithium battery is approximately twice that of an alkaline battery with a somewhat louder horn output as a result of the battery's higher output voltage.

CALIBRATION PROCEDURE DUAL SET POINT ELECTRONIC PRESSURE SWITCH MOUNTED INSIDE A-100 MONITOR



LOCATION OF CALIBRATION
TRIM POTS, TOP VIEW

The electronic pressure switch can be calibrated either as a direct acting or reverse acting single point switch, or as a dual set-point switch that can alarm within or outside of a gap via the two calibration trim pots located at the top of the unit. The calibration procedures are as follow:

Trim pots are multi-turn (11 turns) with slip clutch at each end. When Setting to full CW or full CCW turn screw a minimum of 15 full turns in the appropriate direction. The trim pots are located in the top of the transducer electronic module labeled R-1 and R-2.

DIRECT ACTING SINGLE POINT: (Output goes from low to high at the set-point on increasing pressure)

Set R-1 fully CCW.
Apply set pressure at the port.
adjust R-2 CW to raise set-point, or CCW to lower set-point.

REVERSE ACTING SINGLE POINT: (Output goes from high to low at the set-point on increasing pressure)

Set R-2 fully CW.
Apply set pressure at the port.
adjust R-1 CW to raise set-point, or CCW to lower set-point.

ALARM OUTSIDE OF A GAP: (Output goes high below a low pressure set-point or above a high pressure set-point)

Temporarily set R-2 fully CW.
Apply low set pressure at the port.
adjust R-1 until alarm goes on (output goes high), CW to raise/CCW to lower .
Raise set pressure to the high value (alarm will clear and output will go low).
Adjust R-2 CCW until alarm goes back on (output goes high).



INDUSTRIAL FLUID CONTROLS CINCINNATI, OHIO 45246
(513) 874-8499



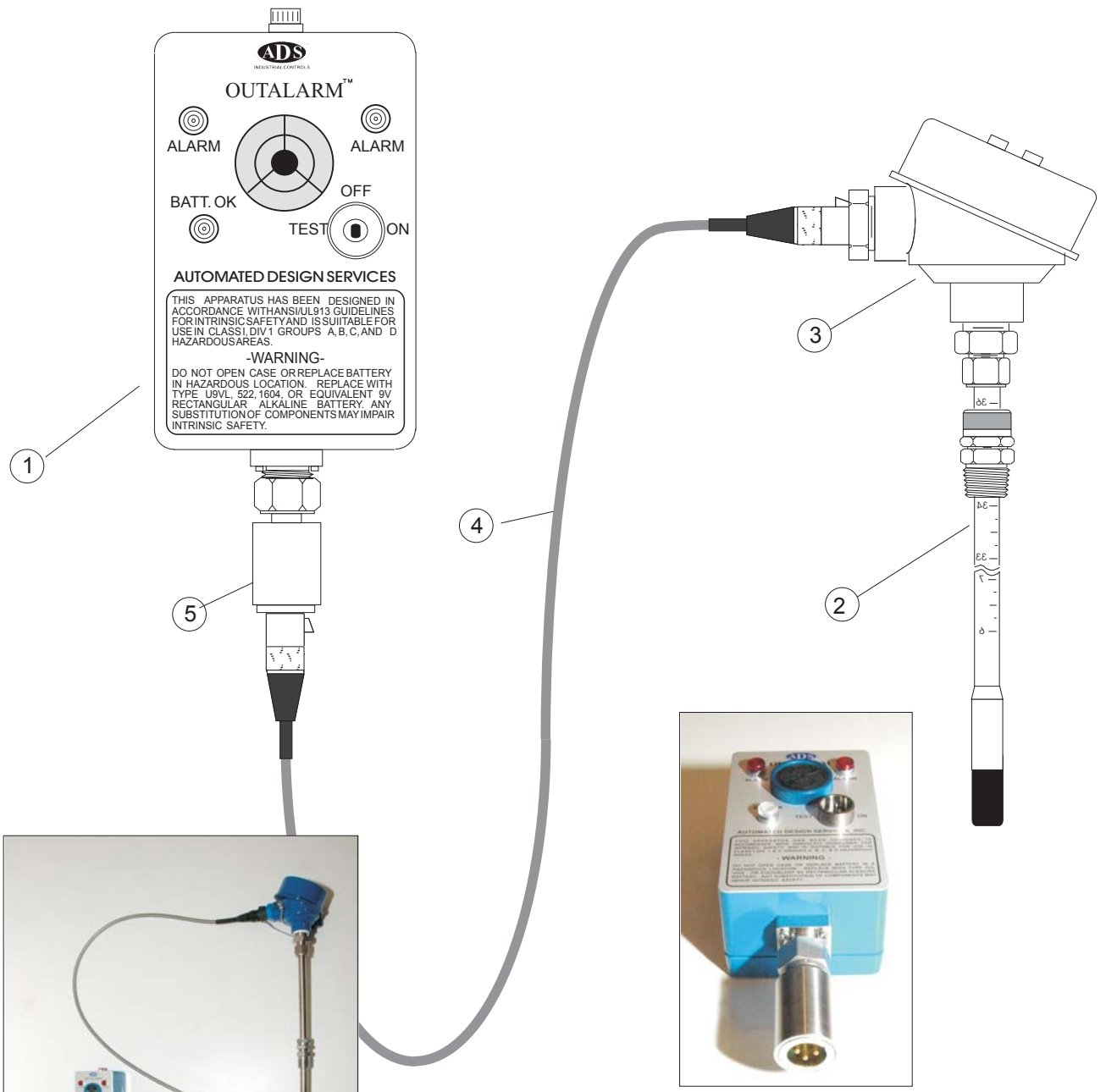

- ① MONITOR A100-MTR
- ② PROBE A100-PRB-3FT
- ③ A200 PROBE CONNECTOR HEAD
- ④ 25 FT CABLE, MODEL A200-CA-3PIN-25FT
- ⑤ A100 CABLE-TO-MONITOR ADAPTER



INDUSTRIAL FLUID CONTROLS
 CINCINNATI, OHIO 45246
 (513) 874-8499



JOSEPH SHEFSKY, P.E.		09/11/12
A-100 WITH REMOTE CONNECTED A-200 PROBE WITH HEAVY DUTY CONNECTOR		
DRAWING NO.	20120911-1	

HAZARDOUS AREA
CLASS I, DIV 1, GR. A, B, C, & D

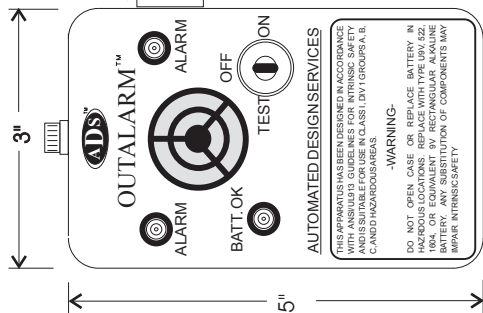

INTRINSICALLY SAFE REMOTE OPTO-ISOLATED TRANSISTOR OUTPUT

CABLE, 2/C SS INTERLOCKING ARMOR QUICK CONNECT CORROSION RESISTANT CONNECTORS AT BOTH ENDS. STANDARD LENGTH 12 FT., LONGER LENGTHS OPTIONAL.

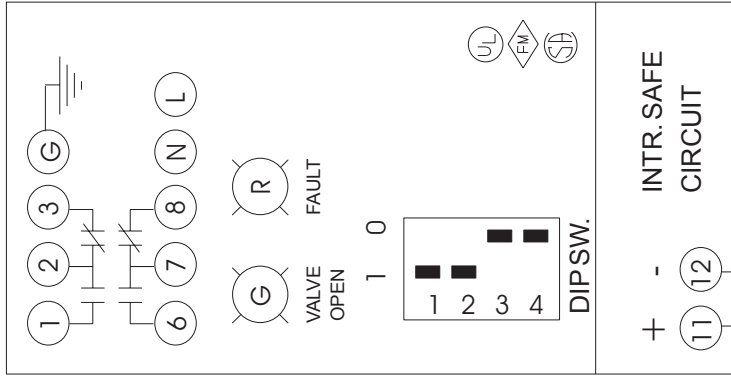

DIPSWITCH SETTINGS

A-200-9251/01-40 SW. AMPL.

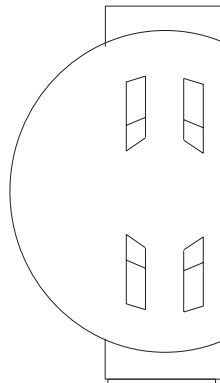

FIELD-TO-CONTROL ROOM WIRING. UP TO 12,000 FT. 2/C #20 AWG FOR GROUPS A & B. LONGER LENGTHS FOR GROUPS C & D.



INDUSTRIAL FLUID CONTROLS
CINCINNATI, OHIO 45246
(513) 874-8499



JOSEPH SHEFSKY, P.E. 2/23/90

MODEL A-100 OUTALARM REMOTE ALARM HOOK-UP FOR SHUTDOWN

DRAWING NO. 9002232

REV 7/01

REMOTE OUTPUT MODEL A-100 *Outalarm*TM

The remote output option of the Model A-100 *Outalarm*TM features a solid state Opto-isolator consisting of an infrared emitting diode optically coupled to a silicon photo-transistor that functions as a solid state DC switch. The absolute maximum ratings of the switch are as follow:

Output photo-transistor switch maximum ratings:

Power Dissipation	150 mW
Forward Current	150 mA
(Continuous)	
Maximum Voltage	100 Volts
Max voltage drop	1.5 Volts
($I_F = 10 \text{ mA}$)	
Capacitance	50 picofarads

The solid state switch can be considered as a passive non-incendive device that can be used safely in conjunction with intrinsically safe circuits. Care must be taken to ensure that an approved barrier is used to limit the current and voltage to a safe value consistent with the specific intrinsic safety criteria followed.

CONNECTION:

When connecting the remote output to an external device, take care not to exceed the maximum voltage and current ratings as per the table above. Typical applications include industrial annunciators powered by 6-24 VDC and NAMUR type switching amplifiers such as the ADS, Inc. Model A210-9251/01-40.

Figures 1 and 2 below illustrate typical connections. For Hazardous Areas, an approved barrier should be employed as shown. The Model A210-9251/01-40 switching amplifier has a built-in Factory Mutual, UL, and CSA approved barrier certified for Class I, Div 1 Gr. A,B,C,D Hazardous areas.

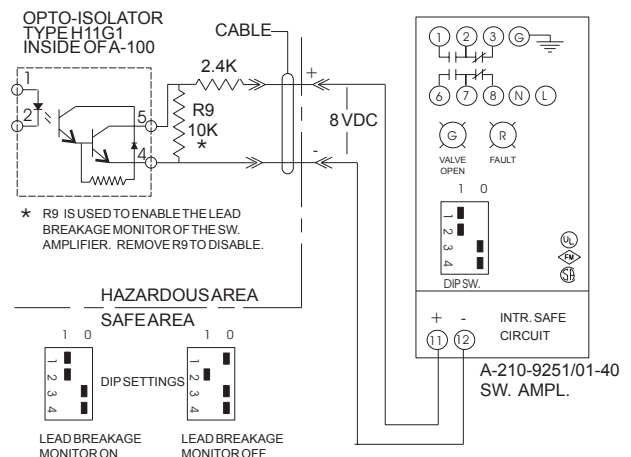

Fig. 1. Connection to remote shutdown.

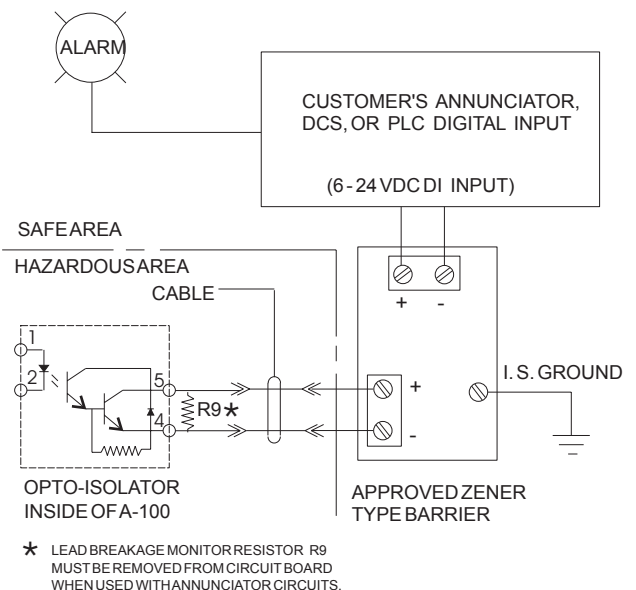

Fig. 2. Connection to remote alarm

INDUSTRIAL FLUID CONTROLS

CINCINNATI, OHIO 45246 (513) 874-8499

dixonvalve.com



Manufacturers of liquid level controls for overfill prevention.

- Liquid terminal automation
- Field storage

NOW WITH OPTIONAL GROUND
VERIFICATION AND TILT INTERLOCKS
FOR ADDITIONAL PROTECTIVE LAYERS

ADS, Inc. Model A210 *Spillguard*[™] HI LEVEL SHUTDOWN SYSTEM for tank cars, tank trucks, barges, ships. . . . *the simple and economical solution. Prevent spills, personnel exposure, overloading.* Suitable for open and closed dome loading.

FEATURES:

- Rugged Explosion Proof, weather and corrosion resistant control unit with LED status lights visible through glass cover.
- Intrinsically safe all solid state probe, suitable for Class I, II, III, Div 1 Groups A, B, C, & D in conjunction with supplied controller. Inserts into tank through standard 1/2" NPT fitting.
- Probe can be portable or permanently installed in vessel.
- Variable insertion length, laser engraved graduated rod with 1/4" graduations.
- Optional self test feature permits testing entire system prior to loading product.
- Optional tilt and ground verification interlocks for added protection layers.
- Rugged, corrosion and chemical resistant probe-to-controller cable, protected by stainless steel interlocking armor sheath with heavy duty latching connectors at both ends.
- Fail safe design. Unit trips in the event of an open or shorted cable or loss of power.
- Relay output, 2 form C contacts.
- Optional latching circuit with explosion proof reset push button switch.

SPECIFICATIONS:

- Controller housing NEMA 4X, NEMA 7, Explosion Proof, Class I, II, Groups B, C & D.
- Choice of sensor technologies, capacitance, conductivity, ultrasonic, temperature, or float.
- Insertion length 4" to 60" adjustable, longer lengths available.
- Wetted materials 316 SS, Teflon. Other materials available.
- Sensor suitable for Class I, II, III, Div 1, Gr. A, B, C, & D when used with supplied controller and cable lengths of 10,000 ft. or less.
- Input power either 120 VAC, 240 VAC OR 24 VDC, 2.5 Watts.
- Output relay contacts, 2 form C (2PDT) rated 2 amps at 120/240 VAC, 1 form C (SPDT) with optional latching circuit and reset switch.
- Sensor excitation open circuit voltage 8 VDC, short circuit current 8 MA with built in FM approved barrier.
- Output relay deenergizes on high level, broken or shorted sensor cable, or loss of power.
- Probe temperature range -14 to +212 Deg F.
- Probe pressure rating 50 psig with standard fitting. Consult factory for applications up to 300 psig.
- Standard cable lengths 15, 25, and 50 Ft. Other lengths available.
- Cable connectors are designed for repeated mating and meet IP 65 mechanical and environmental specs.

INDUSTRIAL FLUID CONTROLS

CINCINNATI, OHIO 45246 (513) 874-8499

dixonvalve.com

HAZARDOUS AREA

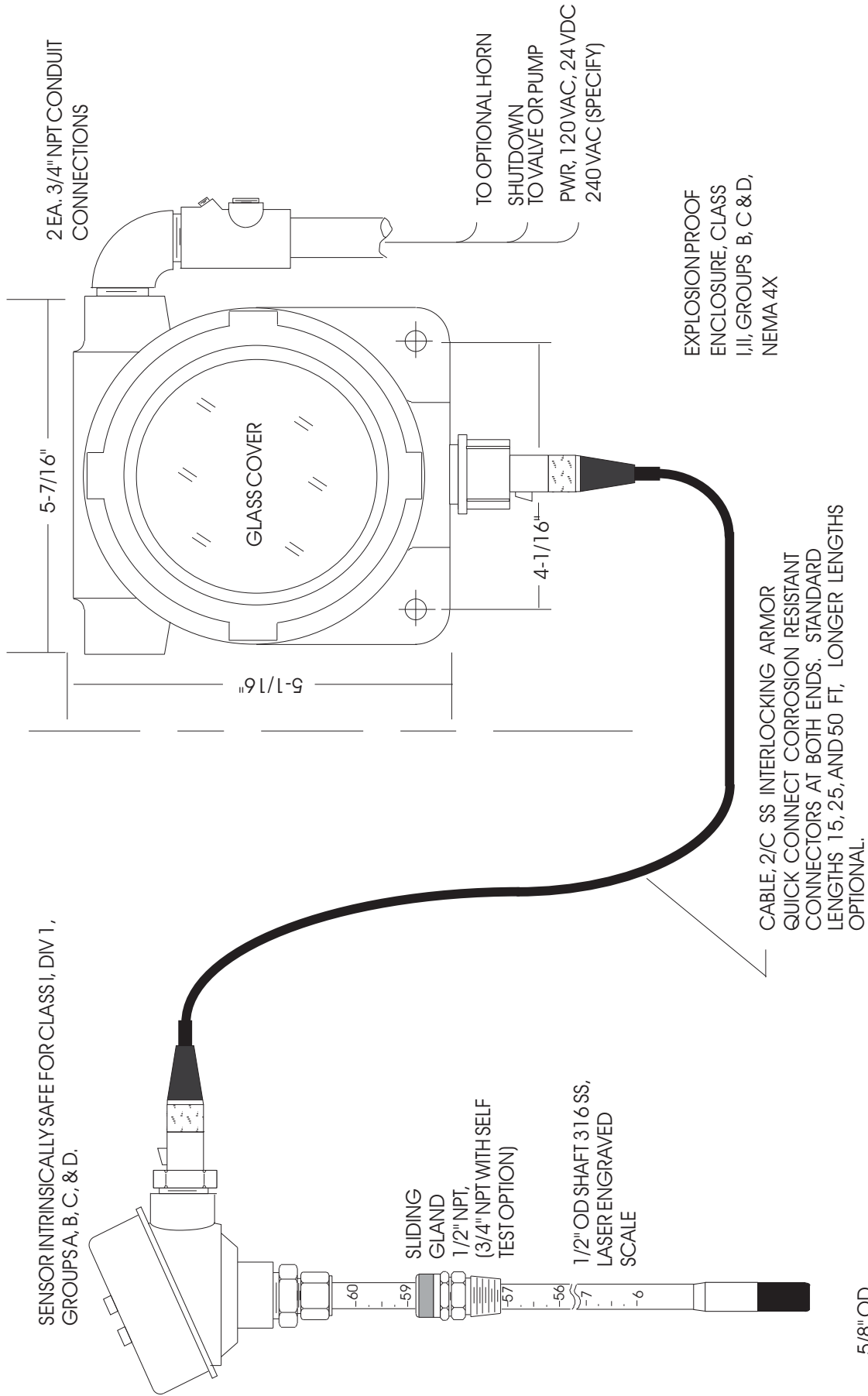

SENSOR INTRINSICALLY SAFE FOR CLASS I, DIV 1, GROUPS A, B, C, & D.

SLIDING GLAND 1/2" NPT. (3/4" NPT WITH SELF TEST OPTION)

1/2" OD SHAFT 316 SS, LASER ENGRAVED SCALE

5/8" OD TIP, TEFLON

EXPLOSION PROOF ENCLOSURE, CLASS I, II, GROUPS B, C & D, NEMA 4X

TO OPTIONAL HORN SHUTDOWN TO VALVE OR PUMP
PWR, 120VAC, 24VDC
240VAC (SPECIFY)

CABLE, 2/C SS INTERLOCKING ARMOR
QUICK CONNECT CORROSION RESISTANT CONNECTORS AT BOTH ENDS. STANDARD LENGTHS 15, 25, AND 50 FT. LONGER LENGTHS OPTIONAL.

 <p>INDUSTRIAL FLUID CONTROLS CINCINNATI, OHIO 45246 (513) 874-8499</p>	 <p>JOSEPH SHEFSKY, P.E. MODEL A-210 HIGH LEVEL SHUTDOWN SYSTEM INTRINSICALLY SAFE, FM APPROVED COMPONENTS</p>	<p>6/25/91</p> <p>DRAWING 910625-1</p> <p>REV 08/13</p>
---	---	---

OPTIONAL LATCH
RESET SWITCH,
EXPLPROOF

DIP SWITCH SETTINGS

4 Lead fault detection
OFF: Deactivated
ON: Activated

3 Action
OFF: Sensor Dry: relay de-energized
Sensor Wet: relay energized)
ON: Sensor Dry: relay energized
Sensor Wet: relay de-energized)

2 Not used

1 Not used

MODEL
A210-9170/10-11-21
AUTOMATED DESIGN SERV., INC.

ⓐ POWER
Ⓡ FAULT
ⓐ RESET

DIP SETTINGS
(UNDER FRONT PANEL)



BOTTOM
(GREEN)
7 9
120/230 VAC

MIDDLE
(BLACK)
4 5 6

TOP
(BLACK)
1 2 3

IS CIRCUIT
(BLUE)
10 +
11 -

GND



LED LOGIC:

	GREEN	AMBER	RED
POWER ON	ON	---	---
RESET	ON	ON	OFF
TRIPPED	ON	OFF	OFF
FAULT	ON	OFF	ON
POWER OFF	OFF	OFF	OFF

RELAY DE-ENERGIZES ON
HIGH LEVEL OR FAULT.

NOTE:

WITH THE RESET SWITCH OPTION POWER IS REMOVED FROM SWITCHING AMP WHILE IN THE TRIPPED STAGE, THEREFORE THE RED LED WILL NOT COME ON IF A FAULT CONDITION CAUSED THE TRIP. TO DETERMINE IF THE TRIP IS DUE TO A FAULT, DEPRESS AND HOLD THE RESET SWITCH AND OBSERVE THE STATUS OF THE RED LED. RED LED ON MEANS TRIP DUE TO FAULT, RED LED OFF MEANS THAT THE TRIP IS DUE TO HIGH LEVEL.

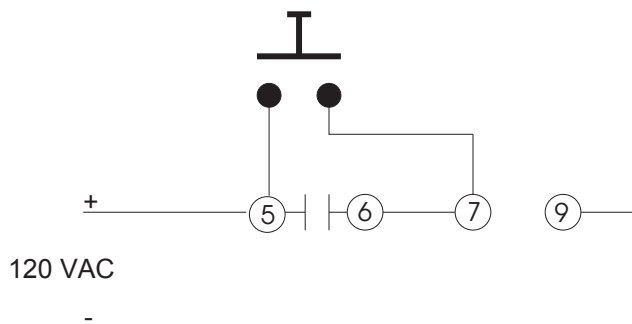

OPTIONAL LATCH CIRCUIT WIRING DIAGRAM



INDUSTRIAL FLUID CONTROLS
CINCINNATI, OHIO 45246
(513) 874-8499



JOSEPH SHEFSKY, P.E.

02/07/07

MODEL A-210 CONTROLLER, 120/230 VAC
AMPLIFIER, ADS MODEL A-210-9170/10-11-21

DRAWING NO.

20070207-1

rev 091815

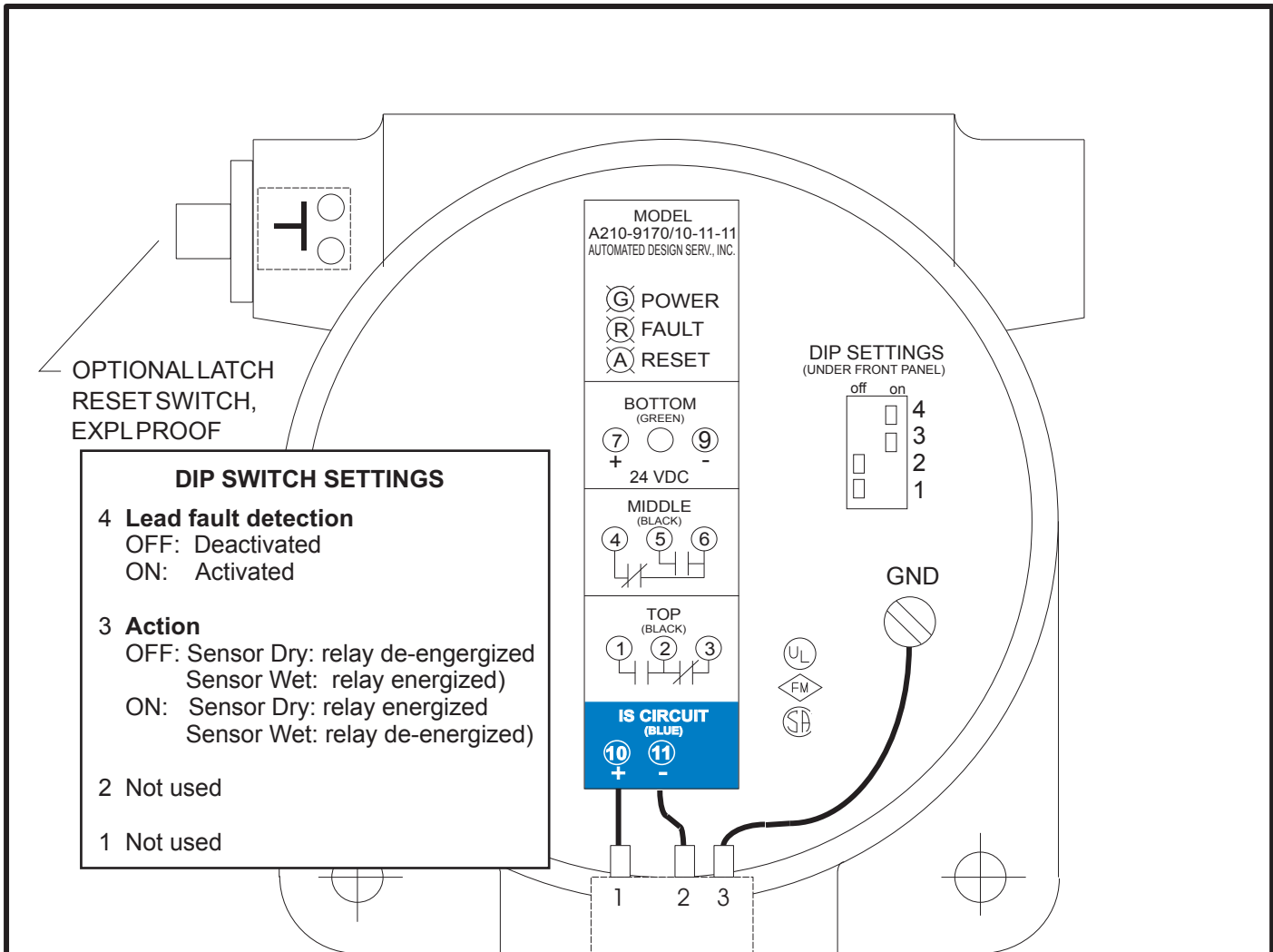

DIP SWITCH SETTINGS

4 Lead fault detection
 OFF: Deactivated
 ON: Activated

3 Action
 OFF: Sensor Dry: relay de-energized
 Sensor Wet: relay energized)
 ON: Sensor Dry: relay energized
 Sensor Wet: relay de-energized)

2 Not used

1 Not used

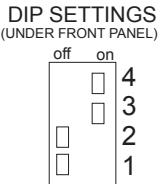

LED LOGIC:

	GREEN	AMBER	RED
POWER ON	ON	---	---
RESET	ON	ON	OFF
TRIPPED	ON	OFF	OFF
FAULT	ON	OFF	ON
POWER OFF	OFF	OFF	OFF

NOTE:

WITH THE RESET SWITCH OPTION POWER IS REMOVED FROM SWITCHING AMP WHILE IN THE TRIPPED STAGE, THEREFORE THE RED LED WILL NOT COME ON IF A FAULT CONDITION CAUSED THE TRIP. TO DETERMINE IF THE TRIP IS DUE TO A FAULT, DEPRESS AND HOLD THE RESET SWITCH AND OBSERVE THE STATUS OF THE RED LED. RED LED ON MEANS TRIP DUE TO FAULT, RED LED OFF MEANS THAT THE TRIP IS DUE TO HIGH LEVEL.

RELAY DE-ENERGIZES ON HIGH LEVEL OR FAULT.

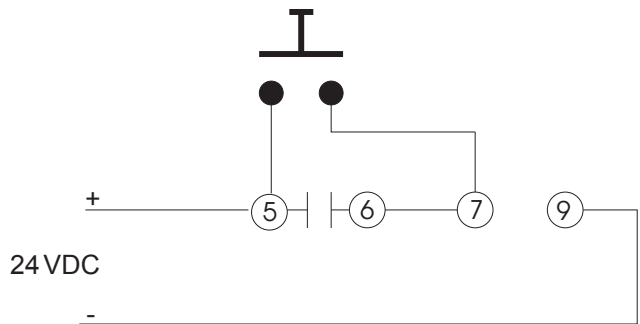

OPTIONAL LATCH CIRCUIT WIRING DIAGRAM



INDUSTRIAL FLUID CONTROLS
 CINCINNATI, OHIO 45246
 (513) 874-8499



JOSEPH SHEFSKY, P.E.

02/07/07

MODEL A-210 CONTROLLER, 24 VDC
 AMPLIFIER, ADS MODEL A-210-9170/10-11-11

DRAWING NO.

20070207-2

rev 091815

- INTRINSICALLY SAFE DESIGN, CLASS I, DIV 1, GR. A, B, C, D.
- RUGGED, RELIABLE TIP SENSITIVE Phase-Shift™ CAPACITANCE SENSOR.
- OPERATING TEMPERATURE RANGE -40 to 250F
- WETTED MATERIAL 316SS AND TEFLON™
- GRADUATED ROD, LASER ENGRAVED SCALE.
- VARIABLE INSERTION LENGTH VAPOR TIGHT SLIDING FITTING. STANDARD 1/2" MALE NPT RATED 50 PSI. OPTIONAL 1/2" NPT WITH LOCKING/GROUNDING COLLET RATED 150 PSI, AND 3/4" NPT WITH LOCKING/GROUNDING COLLET RATED 300 PSI.
- WORKS WITH ANY LIQUID WITH A DIELECTRIC CONSTANT OF 1.8 OR GREATER.
- NO CALIBRATION REQUIRED.
- NAMUR OUTPUT, DRY STATE <150 MICROAMPS WET STATE 2.75 MILLIAMPS. ENTITY PARAMETERS L < 0.1 mh, C < 0.5 mf

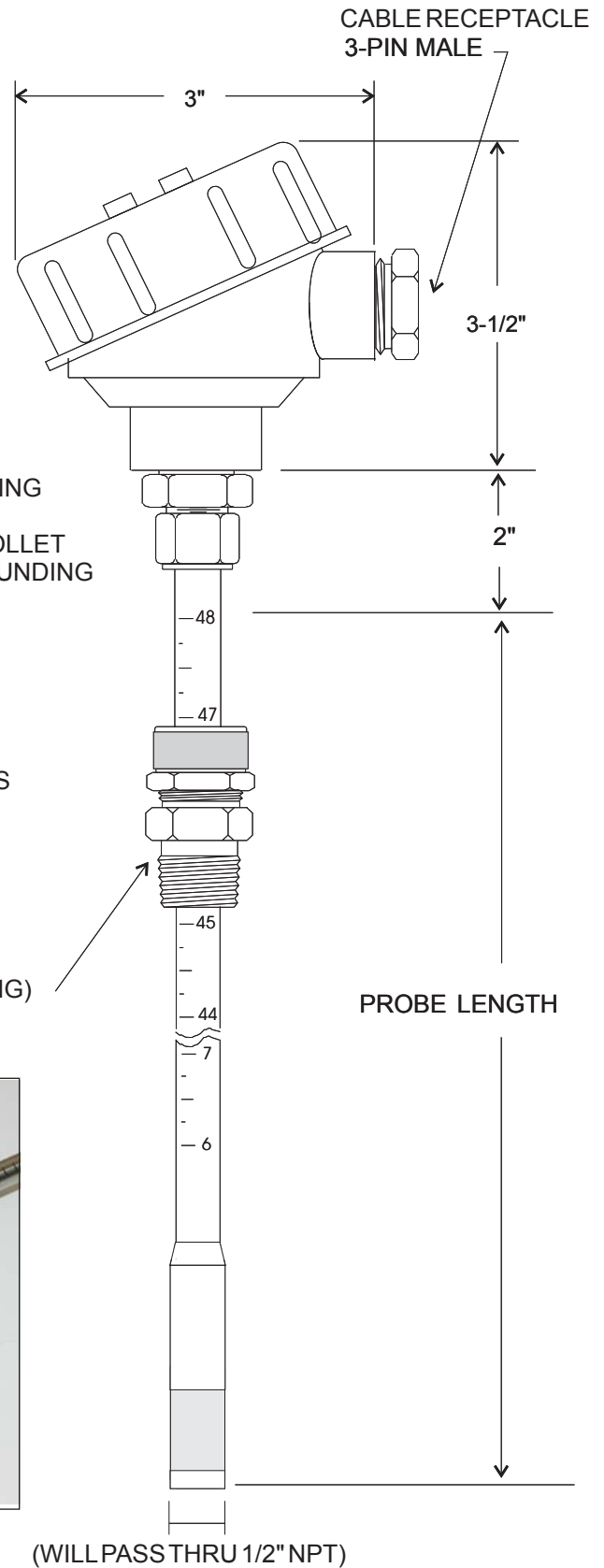

1/2" NPT (3/4" NPT WITH HIGH PRESSURE FITTING)

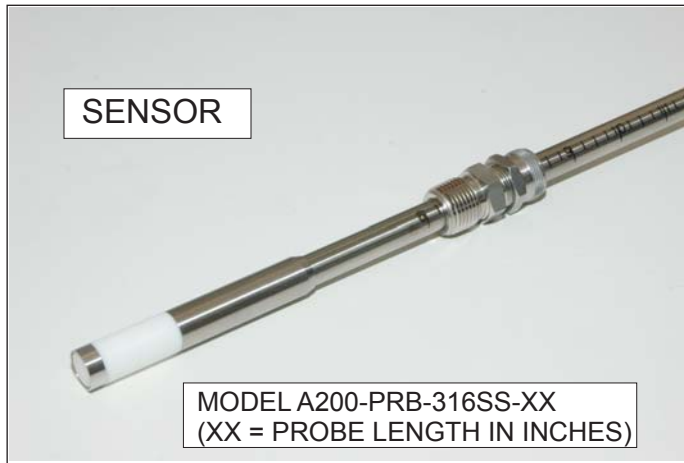

(WILL PASS THRU 1/2" NPT)



INDUSTRIAL FLUID CONTROLS
CINCINNATI, OHIO 45246
(513) 874-8499



JOSEPH SHEFSKY, P.E.

10/15/00

MODEL A-200 LEVEL PROBE, CAPACITANCE SENSOR

DRAWING

2000912-5

REV04/14

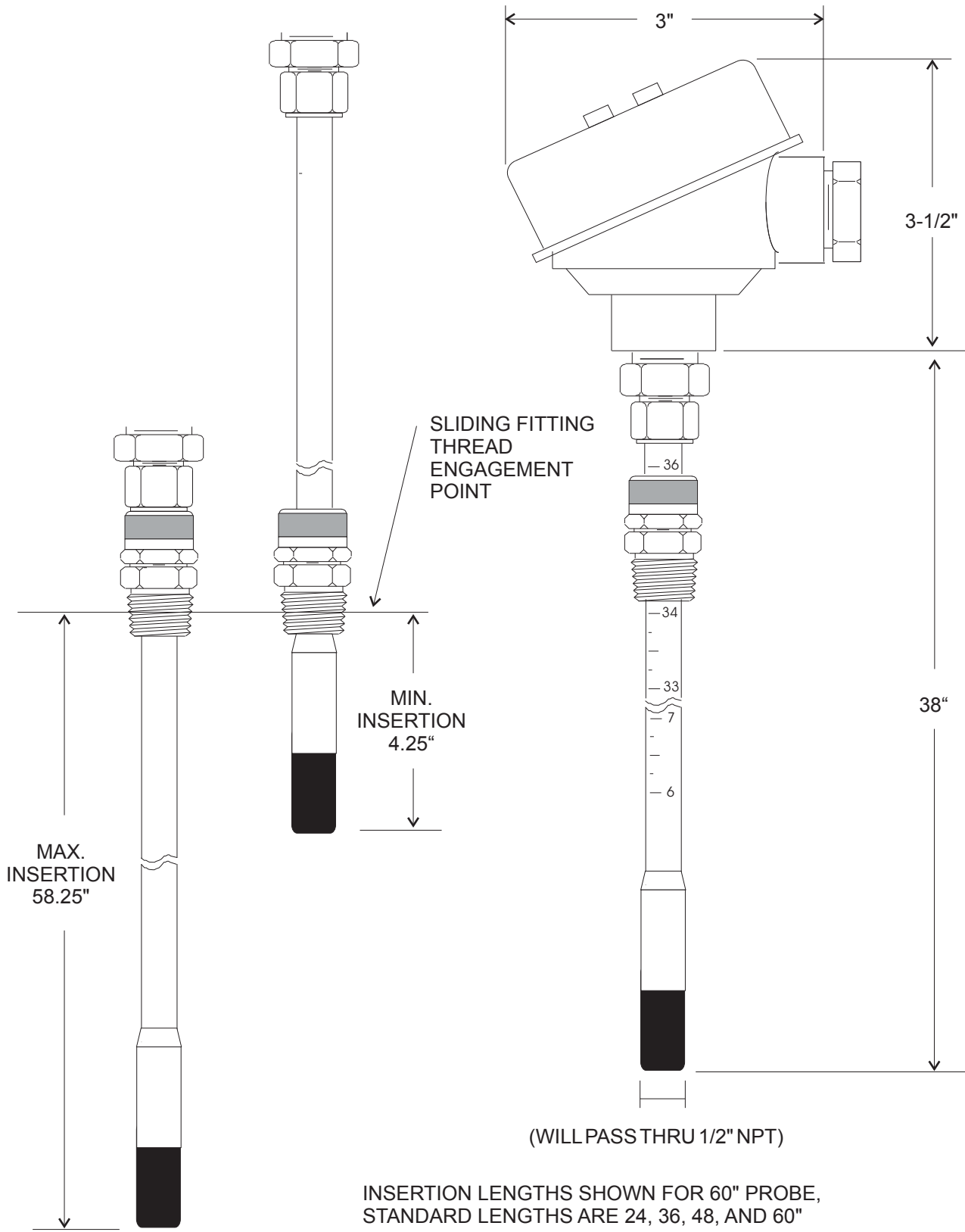

INSERTION LENGTHS SHOWN FOR 60" PROBE,
STANDARD LENGTHS ARE 24, 36, 48, AND 60"



INDUSTRIAL FLUID CONTROLS
CINCINNATI, OHIO 45246
(513) 874-8499



JOSEPH SHEFSKY, P.E.

02/23/09

MODEL A-200 LEVEL PROBE, CAPACITANCE SENSOR
DIMENSIONS

DRAWING

022309-1

REV 07/12



STAINLESS STEEL ARMORED CABLE
STANDARD LENGTHS 15, 20, 25FT.
LENGTHS UP TO 100 FEET AVAILABLE

OUTER SHEATH	304 SS SPIRAL INTERLOCKING ARMOR
WIRE TYPE	3/C SILVER PLATED COPPER, 22 AWG STRANDED PTFE INSULATION, 36AWG SILVER PLATED COPPER BRAID, EXTRUDED JACKET
CABLE ENDS	LATCHING XLR FEMALE GOLD PINS WITH CAPTIVE DUST CAPS

OPTIONS AND ACCESSORIES

TILT AND GROUND VERIFICATION INTERLOCKS FOR A-210 SPILLGUARD SYSTEM

FUNCTION:

The tilt and ground verification interlocks are intended to provide additional layers of protection by ensuring that the probe is properly mounted on the vessel before the system can be reset. The probe can be ordered with either the tilt interlock, ground verification interlock, or both.

TILT INTERLOCK:

The tilt interlock requires that the probe be within 20 deg. of vertical before the system can be reset. When off vertical by more than 20 deg. the output signal stays high (wet state). The tilt sensor located in the probe connector head is electronically filtered to be immune to vibration. The function can be disabled by unplugging the tilt sensor. Refer to the schematic on next page.

GROUND VERIFICATION INTERLOCK:

The ground verification interlock requires that the probe is physically mounted to the tank, **and** the tank be grounded per API RP2003 (less than 10 ohm to ground) before the system can be reset. When these conditions are not met the output signal of the probe will be high (wet state). The function can be disabled by unplugging the ground module. Either the 150 lb or 300 lb sliding fitting is required with this feature to ensure that the probe rod is electrically common with the tank shell via the locking collet of the fitting. See photo and refer to schematic on next page



300 LB



150 LB

OPTIONAL GROUND VERIFICATION AND TILT INTERLOCKS

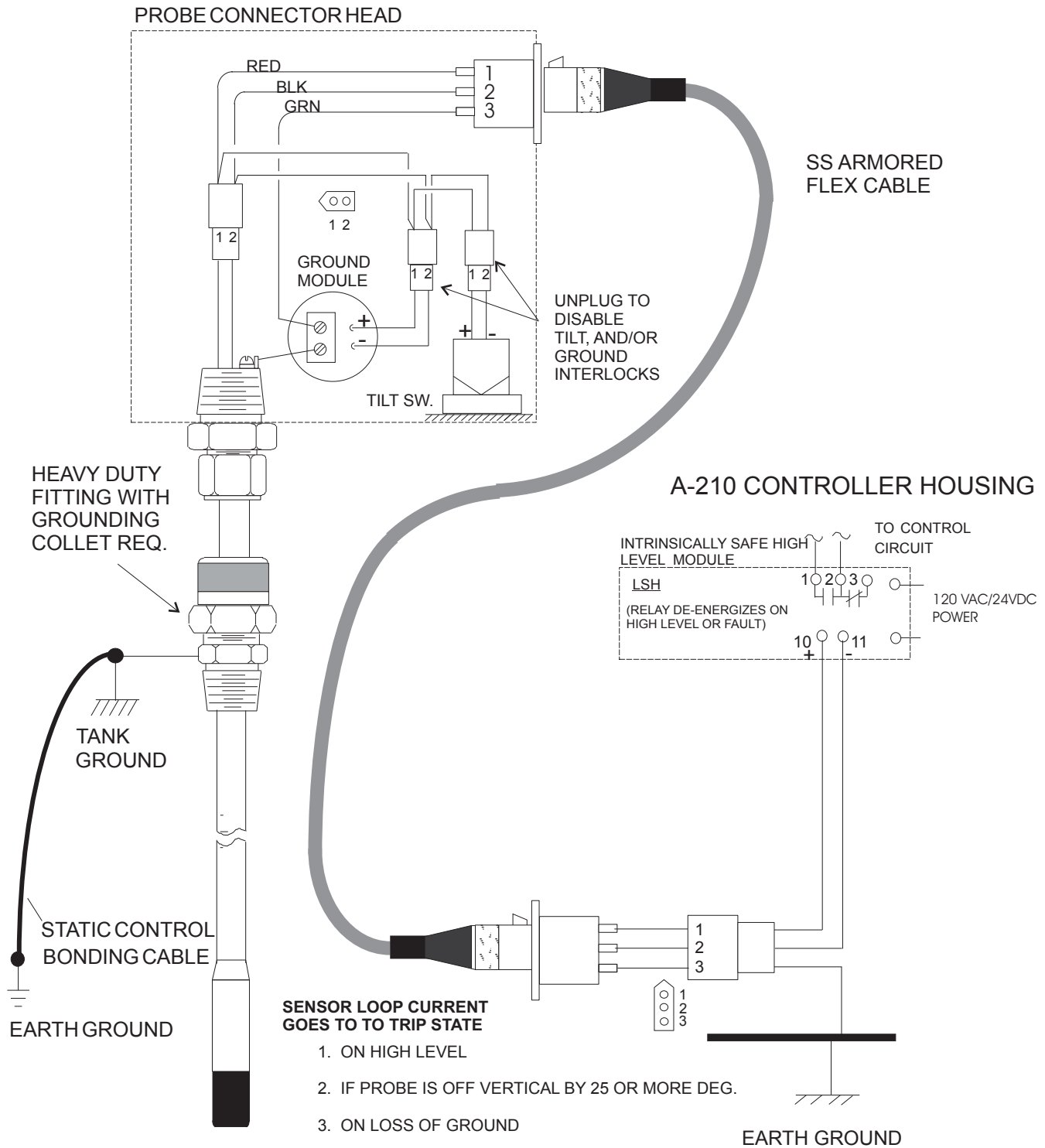

INDUSTRIAL FLUID CONTROLS
CINCINNATI, OHIO 45246
(513) 874-8499

JOSEPH SHEFSKY, P.E.

01/25/14

**MODEL A-210 LEVEL/GROUND/TILT PROBE
CIRCUIT**

DRAWING NO.

20140125-1

Rev 10/10/15

ACCESSORIES

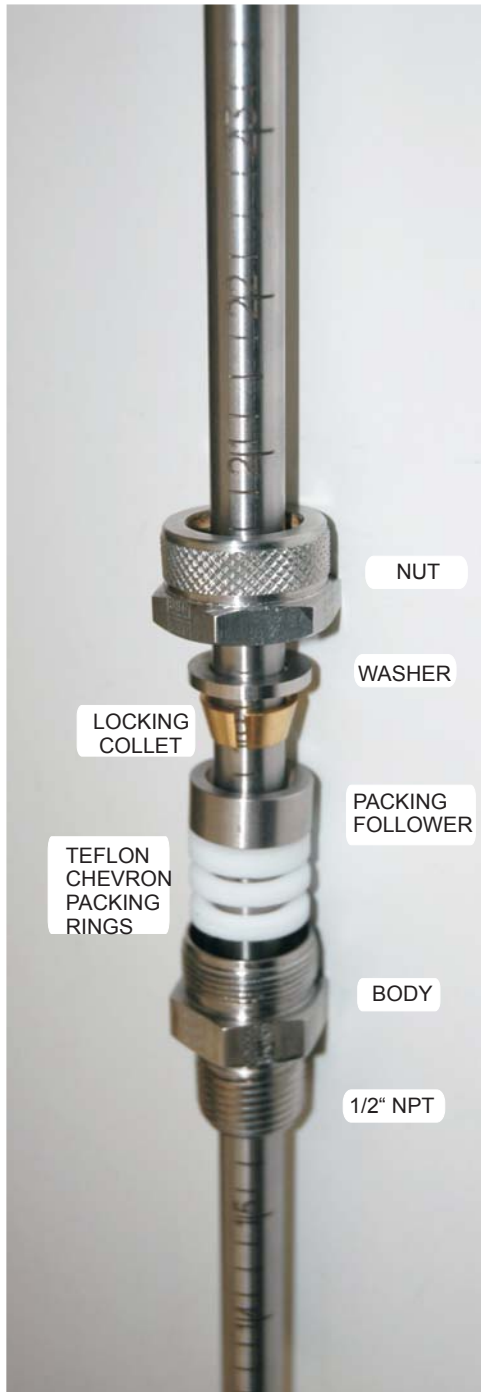

EXPLODED VIEW, 1/2" 150 LB
SLIDING FITTING



EXPLODED VIEW, 3/4" 300 LB
SLIDING FITTING

SELF CLEARING TIMED BYPASS

OPERATION SEQUENCE

- A. On power-up the system comes up un-bypassed.
- B. The bypass function is started by depressing the pushbutton located on the left hub of the A-210 controller. While in the bypass mode the timer relay is energized and de-energizes when timed out.
- C. Depressing the pushbutton during the timing period does not add additional time to the bypass function.
- D. The red LED on the timing module will flash to signify that the trip function is bypassed. The duration of the bypass is set by the rotary switches on the front panel of the timer. The timing range is between 0.1 sec. and 10 days.



INDUSTRIAL FLUID CONTROLS CINCINNATI, OHIO 45246
(513) 874-8499



ATTACH TIMING MODULE

REMOVE THE PROTECTIVE BACKING FROM THE DOUBLE SIDED TAPE ON THE TIMING MODULE (ORANGE) AND FIRMLY PRESS ONTO THE LEFT SIDE OF THE LEVEL MODULE (GRAY) SO THAT THE TOP OF THE TIMING MODULE IS EVEN WITH THE TOP OF THE LEVEL MODULE.



- CAUTION -

WHEN SCREWING THE RESET SWITCH INTO THE HOUSING TAKE CARE NOT TO TWIST THE SWITCH WIRES.

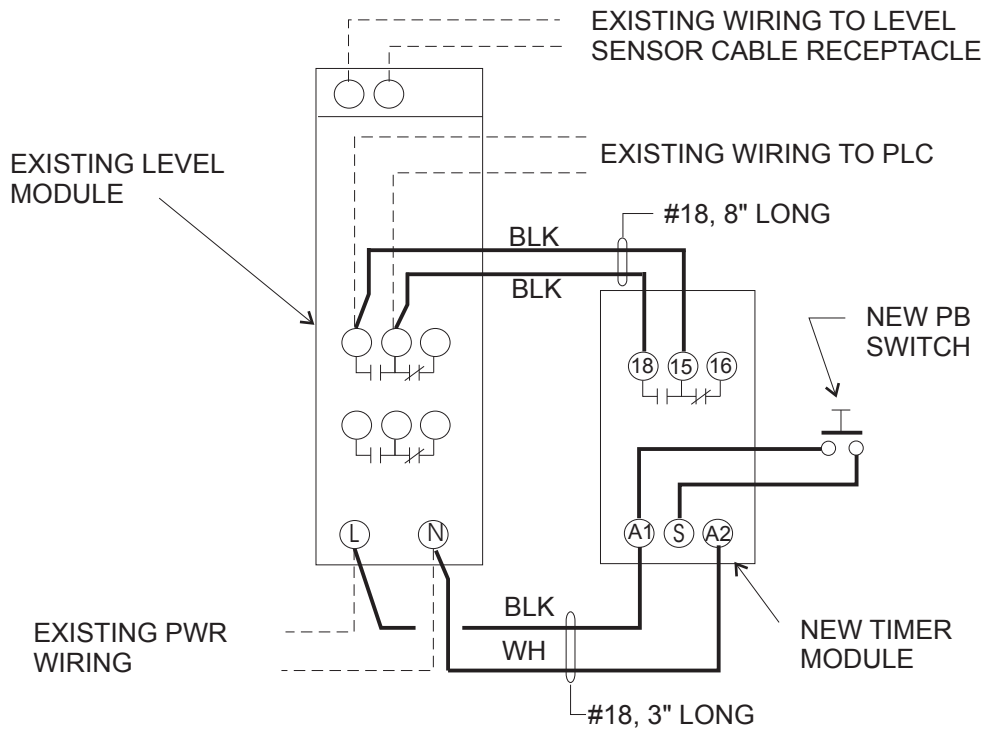

WIRING DETAIL

INDUSTRIAL FLUID CONTROLS CINCINNATI, OHIO 45246
(513) 874-8499



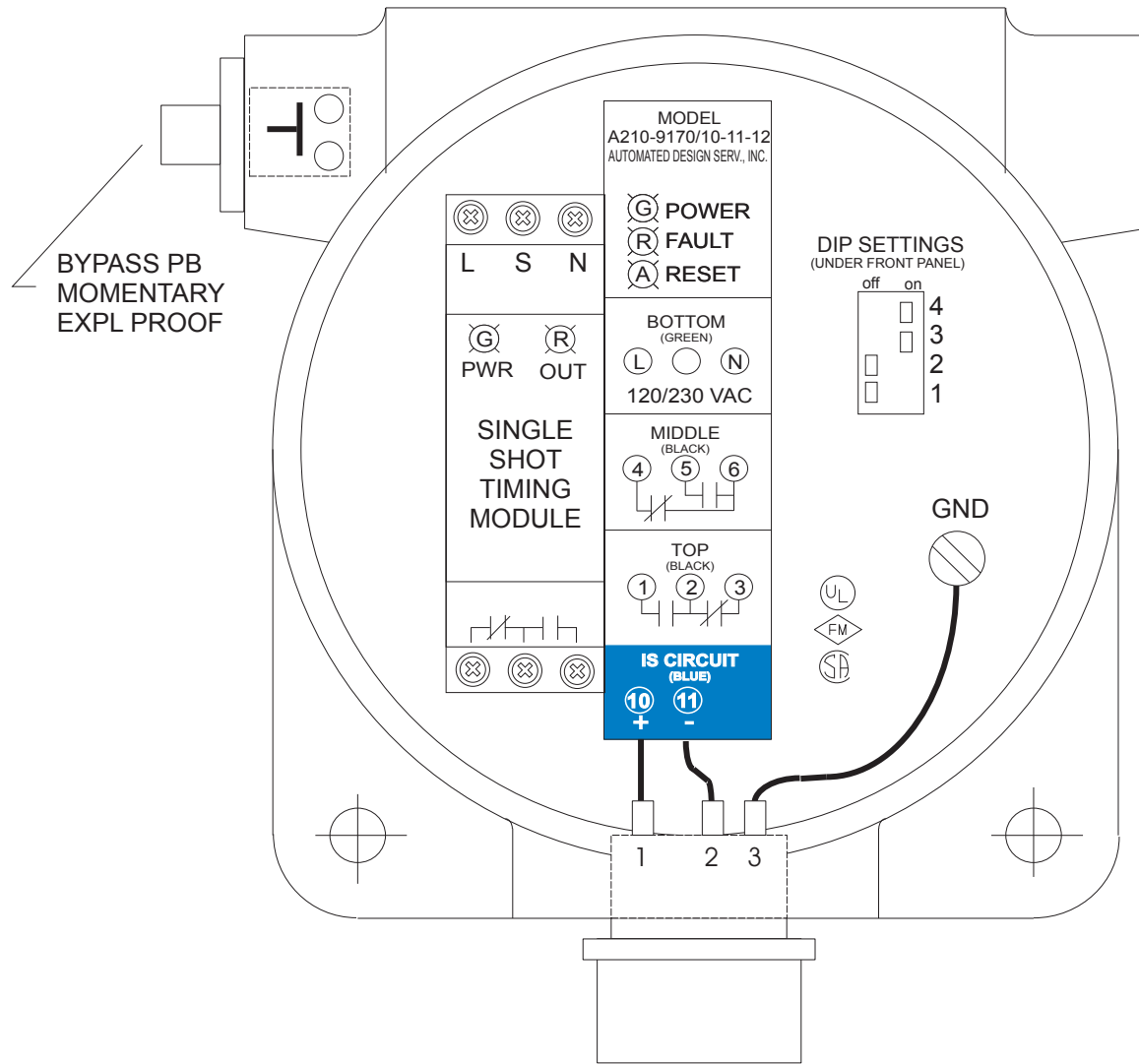

LED LOGIC LIQ LEVEL MODULE:

	GREEN	AMBER	RED
POWER ON	ON	---	---
RESET	ON	ON	OFF
TRIPPED	ON	OFF	OFF
FAULT	ON	OFF	ON
POWER OFF	OFF	OFF	OFF

TIMING MODULE LED LOGIC

	GREEN	RED
POWER ON	ON	---
BYPASS ON	ON	FLASH
BYPASS CLEARED	ON	OFF
POWER OFF	OFF	OFF

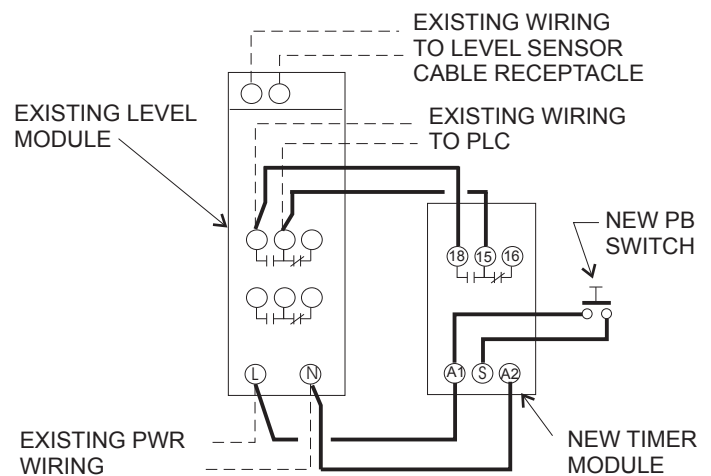

WIRING DETAIL



INDUSTRIAL FLUID CONTROLS
CINCINNATI, OHIO 45246
(513) 874-8499



JOSEPH SHEFSKY, P.E.

06/11/09

A-210 WITH PROPOSED SELF-CLEARING
BYPASS FUNCTION FOR IMTT GEISMAR

DRAWING NO.

SK-061109-1

DRILL 1-3/64" TOP AND BOTTOM

GLUE CONNECTIONS

3/4" PVC COUPLING (2 EA.)

3" PVC PIPE CAP (2 EA.)

3" SCH 40 PVC PIPE, 4.5 FT.

3/4" THIN WALL PVC, 5 FT.

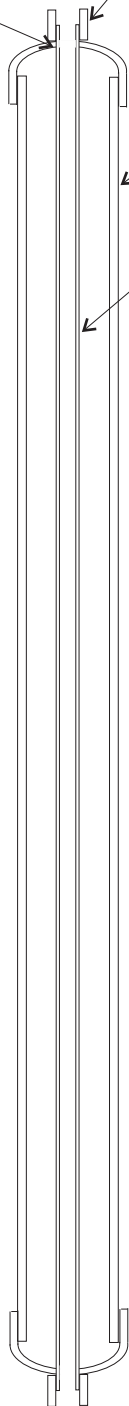

MOUNT OUTSIDE OF HAND RAIL USING 3.5" "U" BOLTS

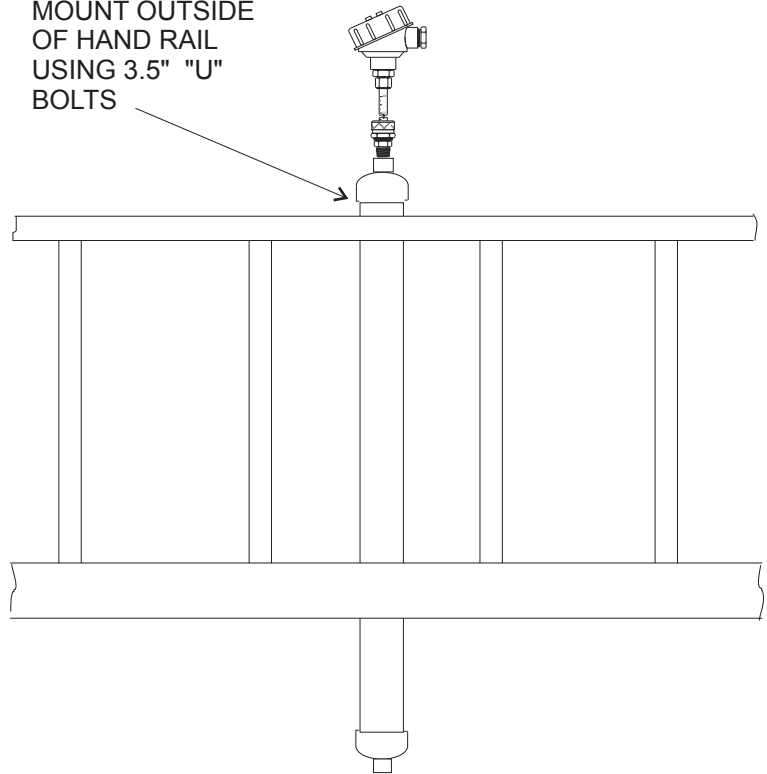

INDUSTRIAL FLUID CONTROLS
 CINCINNATI, OHIO 45246
 (513) 874-8499



JOSEPH SHEFSKY, P.E.

06/11/09

PROPOSED SHIELDED PROBE HOLDER TO PREVENT TRIPPING BY PASSERS BY

DRAWING NO.

SK-061109-2

- INTRINSICALLY SAFE DESIGN, CLASS I, DIV 1, GR. A, B, C, D.
- RUGGED, RELIABLE TIP SENSITIVE *Phase-Shift™* CAPACITANCE SENSOR.
- OPERATING TEMPERATURE RANGE -40 to 250F
- WETTED MATERIAL 316SS AND TEFLON™
- GRADUATED ROD, LASER ENGRAVED SCALE.
- VARIABLE INSERTION LENGTH VAPOR TIGHT SLIDING FITTING. STANDARD 1/2" MALE NPT RATED 50 PSI. OPTIONAL 1/2" NPT WITH LOCKING/GROUNDING COLLET RATED 150 PSI, AND 3/4" NPT WITH LOCKING/GROUNDING COLLET RATED 300 PSI.
- WORKS WITH ANY LIQUID WITH A DIELECTRIC CONSTANT OF 1.8 OR GREATER.
- NO CALIBRATION REQUIRED.
- NAMUR OUTPUT, DRY STATE <150 MICROAMPS
WET STATE 2.75 MILLIAMPS. ENTITY PARAMETERS
L < 0.1 mh, C < 0.5 mf

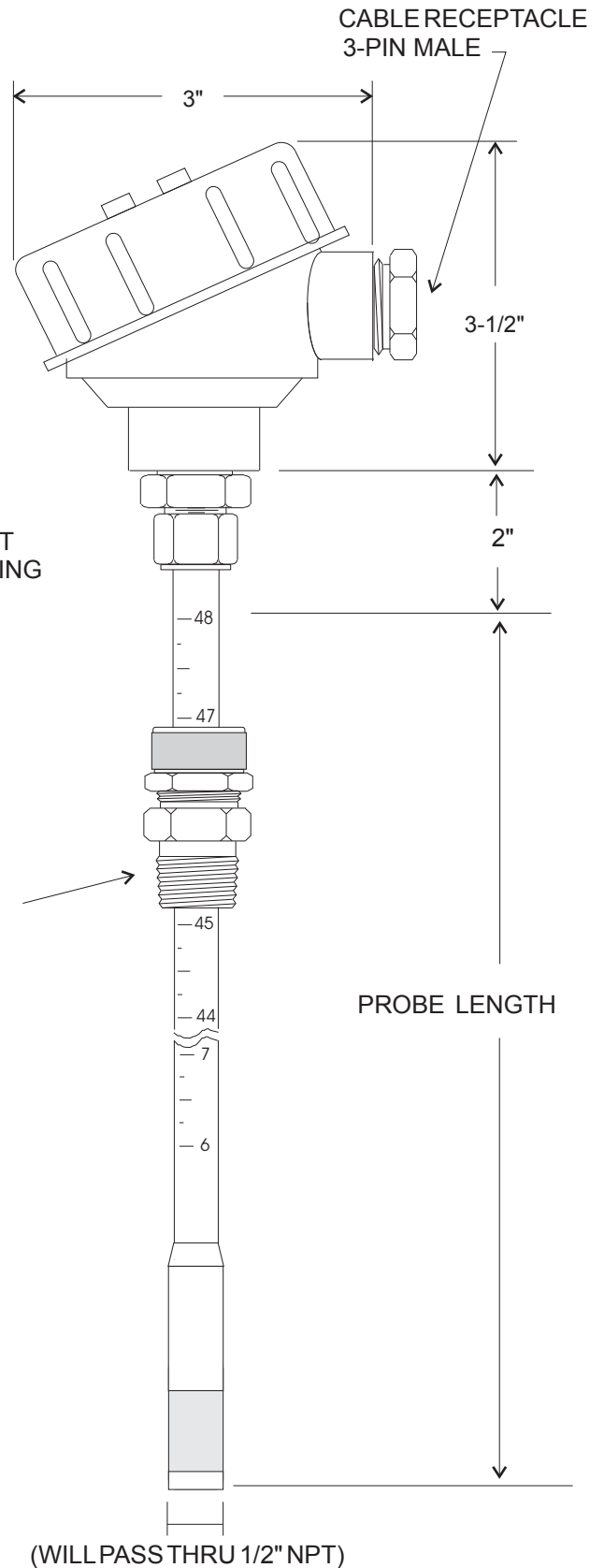

1/2" NPT (3/4" NPT WITH HIGH PRESSURE FITTING)



(WILL PASS THRU 1/2" NPT)



INDUSTRIAL FLUID CONTROLS
CINCINNATI, OHIO 45246
(513) 874-8499



JOSEPH SHEFSKY, P.E.

10/15/00

MODEL A-200 LEVEL PROBE, CAPACITANCE SENSOR

DRAWING

2000912-5

REV 10/15/2014

INDUSTRIAL FLUID CONTROLS

CINCINNATI, OHIO 45246 (513) 874-8499

dixonvalve.com

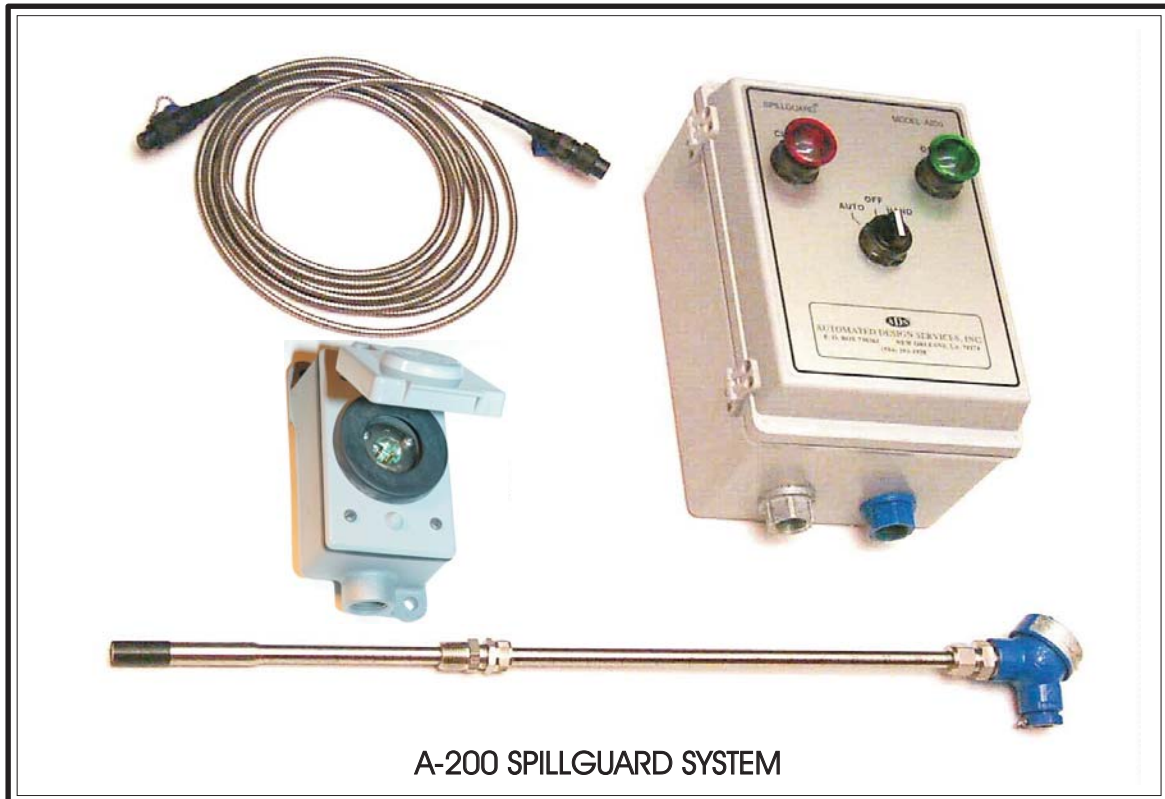

A-200 SPILLGUARD SYSTEM

Manufacturers of liquid level controls for overflow prevention.

- Liquid terminal automation
- Field storage

Model A-200 *Spillguard*[™] high level shutdown system for tank cars, tank trucks, barges, ships *the simple and economical solution.* Prevent spills, personnel exposure, overloading. Suitable for open and closed dome loading

FEATURES:

Single stage fail safe level control. Operator panel provides easy and friendly operation via heavy duty illuminated push button switches. NEMA 4X enclosure with hermetically sealed switches and relays suitable for Class I, Div 2 Hazardous areas. Single point tip sensitive capacitance level probe, intrinsically safe for Class I, Div 1 hazardous areas in conjunction with supplied controller. Adjustable probe insertion length via 1/2" NPT sliding fitting. Probe diameter 1/2" features a laser engraved graduated scale with 1/4" graduations. Rugged corrosion and solvent resistant cable protected by a stainless steel interlocking armor sheath with heavy duty latching connectors at each end. Fail safe design trips in the event of an open or shorted cable or loss of power. Powered output for single stage valve control plus outputs for external horn and strobe light, and contact outputs for pump control. Built in annunciator with silence/acknowledge via the stop button. Setup mode allows system setup and testing prior to loading. Optional ground detector interlock prevents system from being reset if the vessel is not properly bonded to earth.

SPECIFICATIONS:

- Tip sensitive proximity sensor. Works on all liquids with a dielectric constant > 1.9
- Insertion length 4" - 60" adjustable via 1/2" NPT packing gland. Longer lengths available.
- Wetted materials 316 SS, Teflon. Other materials available.
- Sensor intrinsically safe for Class I, Div 1, Gr. A, B, C, & D hazardous areas in conjunction with supplied controller.
- Probe temperature range -40 to +212 Deg F.
- Probe max pressure 50 psig standard fitting, 300 psig heavy duty fitting.
- NEMA 4X enclosure with factory sealed switches and relays suitable for Class I, Div. 2 hazardous areas without purge.
- Open/close lighted pushbuttons, long life LED lamps.
- Optional ground interlock prevents system from being reset if vessel is not properly bonded to ground (resistance from vessel to ground is 10 ohms or less. Green "Ground OK" light provided with this option.
- Fail safe design. Trips in the event of open or shorted cable conductors, or loss of power.
- Stainless steel armored cable, standard length 25 ft. Other lengths available.
- Cable connectors are designed for repeated mating and meet IP-65 environmental specs.



INDUSTRIAL FLUID CONTROLS CINCINNATI, OHIO 45246
(513) 874-8499



HAZARDOUS AREA
CLASS I, DIV 1, GR. A, B, C, & D

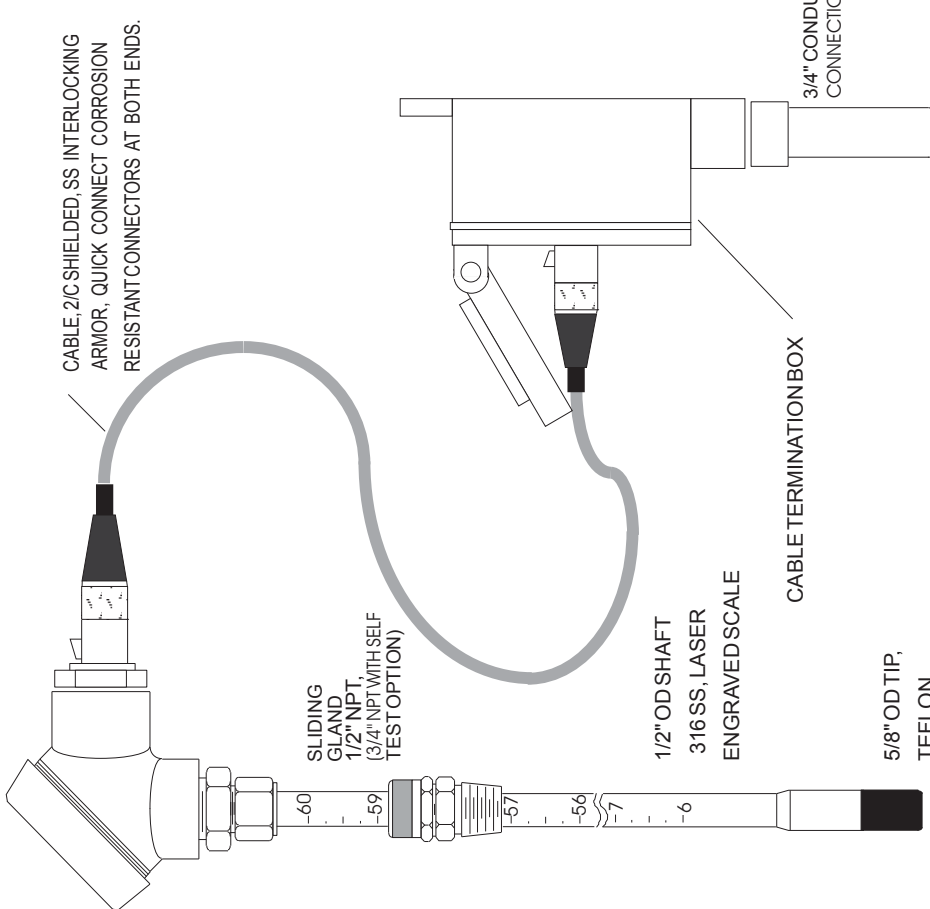

CAUTION: RUN SENSOR CABLE ONLY IN THIS CONDUIT TO MAINTAIN INTRINSIC SAFETY, 2/C SHIELDED.

HAZARDOUS AREA
CLASS I, DIV 2, GR. A, B, C, & D

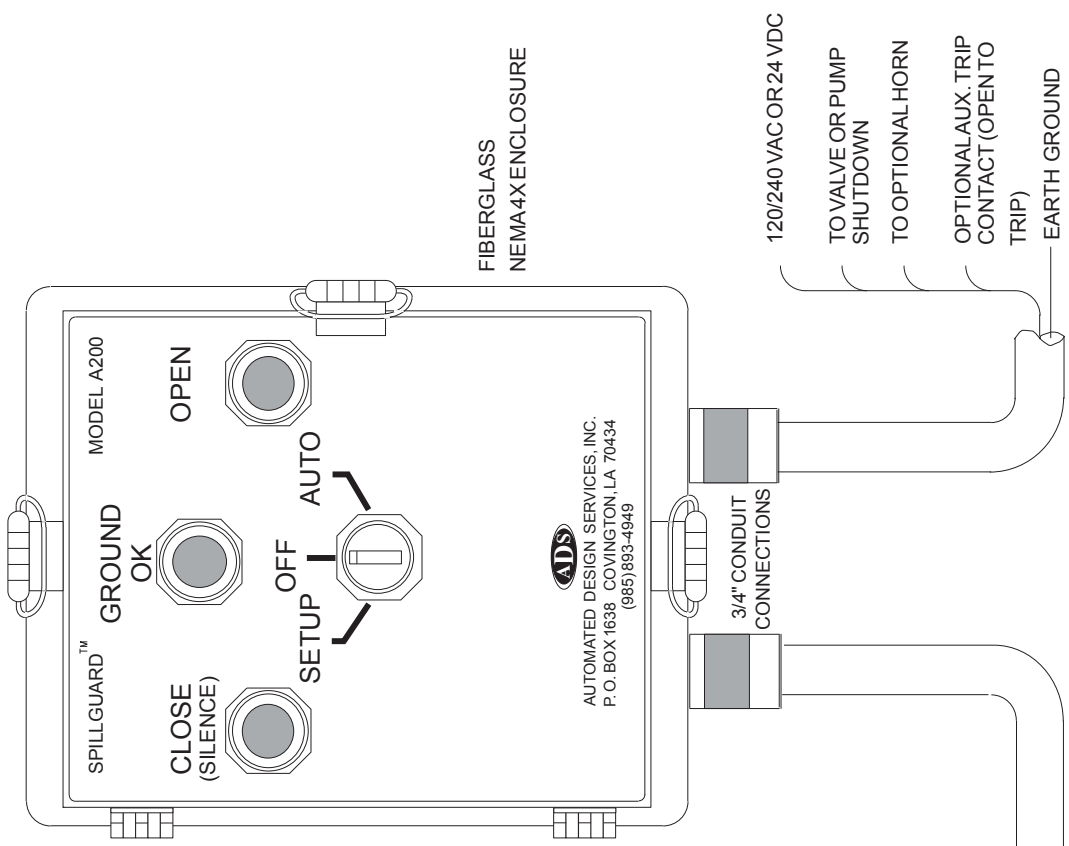

INDUSTRIAL FLUID CONTROLS
CINCINNATI, OHIO 45246
(513) 874-8499



JOSEPH SHEFSKY, P.E.

02-12-06
MODEL A-200 HIGH LEVEL SHUTDOWN SYSTEM
INTRINSICALLY SAFE, FM APPROVED COMPONENTS,
REMOTE CABLE TERMINATION BOX

DRAWING NO. 20060212-1

02/17/10

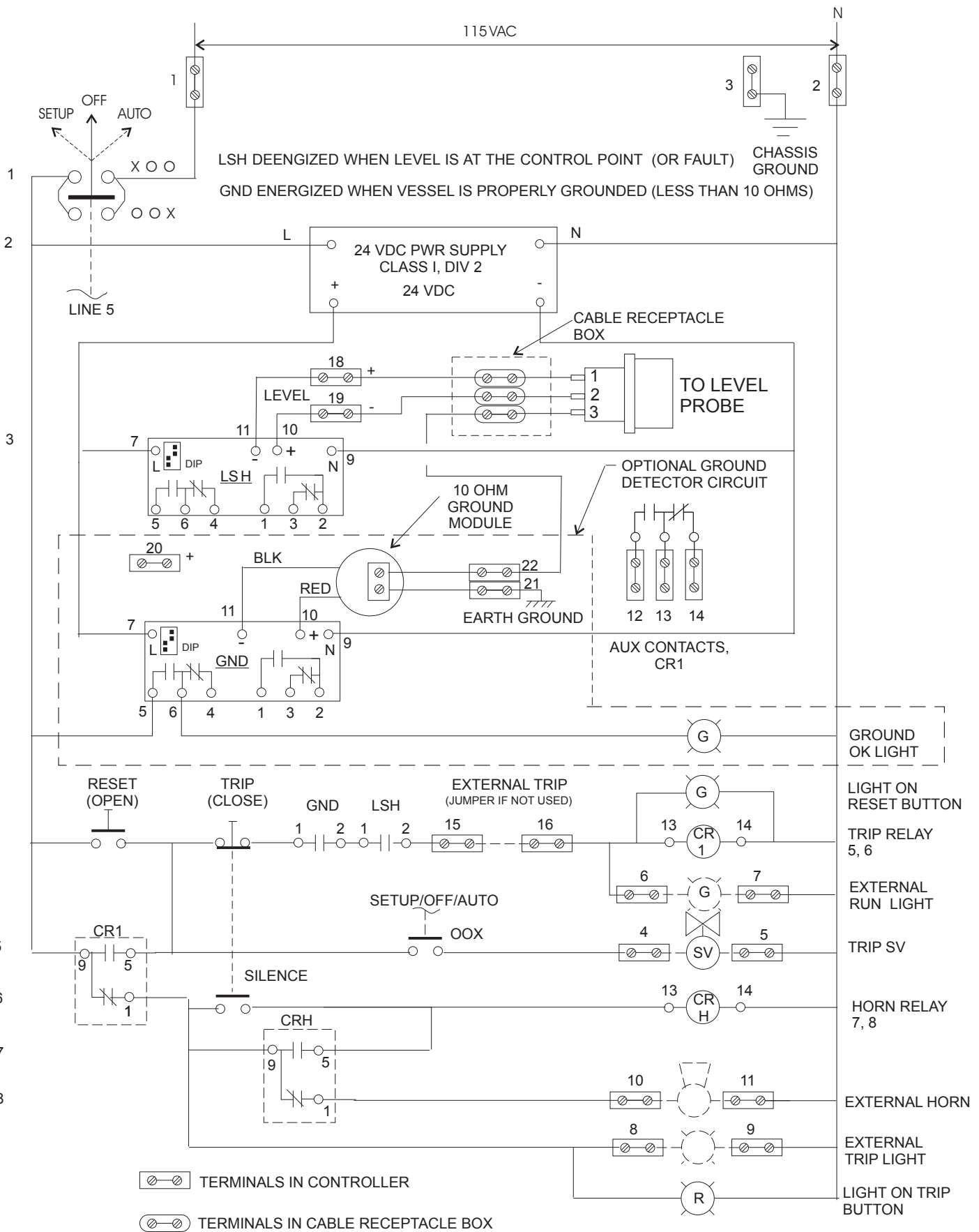

INDUSTRIAL FLUID CONTROLS
CINCINNATI, OHIO 45246
(513) 874-8499



JOSEPH SHEFSKY, P.E.

02/12/06

A200 SCHEMATIC, STANDARD SYSTEM
WITHOUT GROUND INTERLOCK

DRAWING NO.

20060212-2

REV 02/20/10

120 VAC CIRCUITS

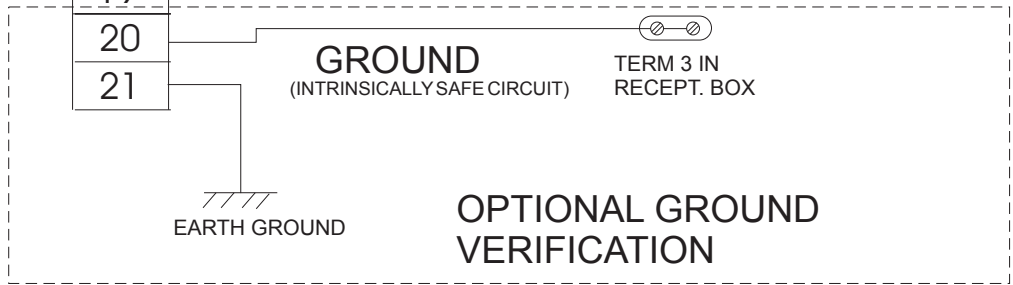
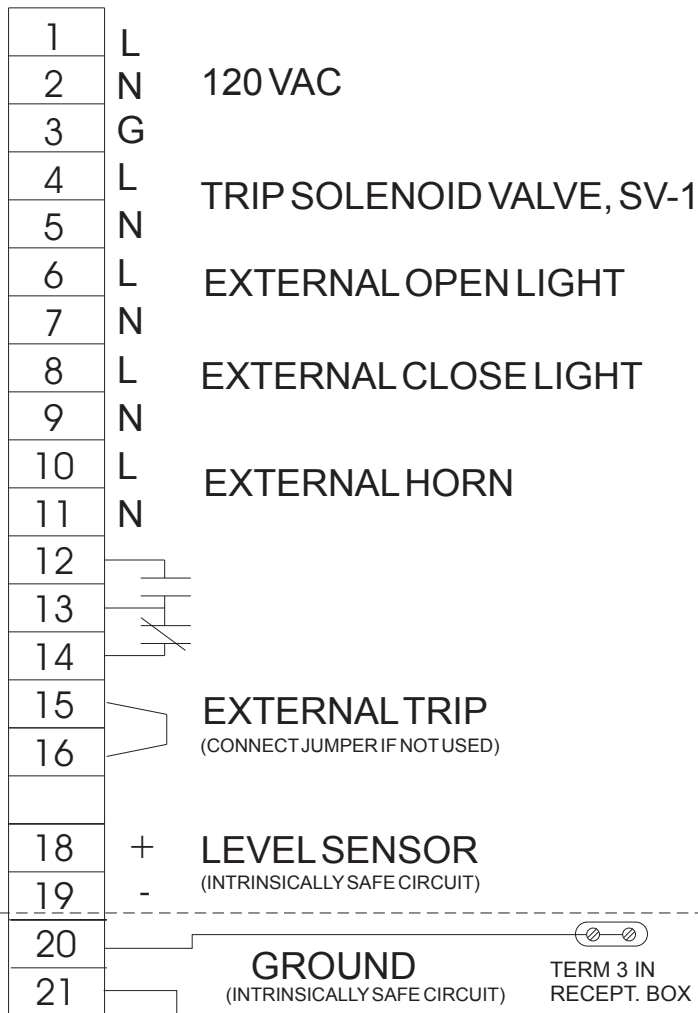

INDUSTRIAL FLUID CONTROLS
CINCINNATI, OHIO 45246
(513) 874-8499



JOSEPH SHEFSKY, P.E.

02/12/06

A200 SCHEMATIC DIAGRAM

DRAWING NO.

20060212-3

REV 02/17/10

- INTRINSICALLY SAFE DESIGN, CLASS I, DIV 1
- RUGGED, RELIABLE TIP SENSITIVE CAPACITANCE SENSOR.
- MAX TEMPERATURE, 212 DEG F MAX
- WETTED MATERIAL 316SS AND TEFLON™
- GRADUATED ROD, LASER ENGRAVED.
- VARIABLE INSERTION LENGTH
- WORKS WITH ANY LIQUID WITH A DIELECTRIC CONSTANT OF 1.8 OR GREATER.
- NO CALIBRATION REQUIRED.
- MAX PRESSURE 50 P(300 P HIGH PRESS FITTING)
- LOW CURRENT DRAW, 0.50 MA AT 5 VDC.

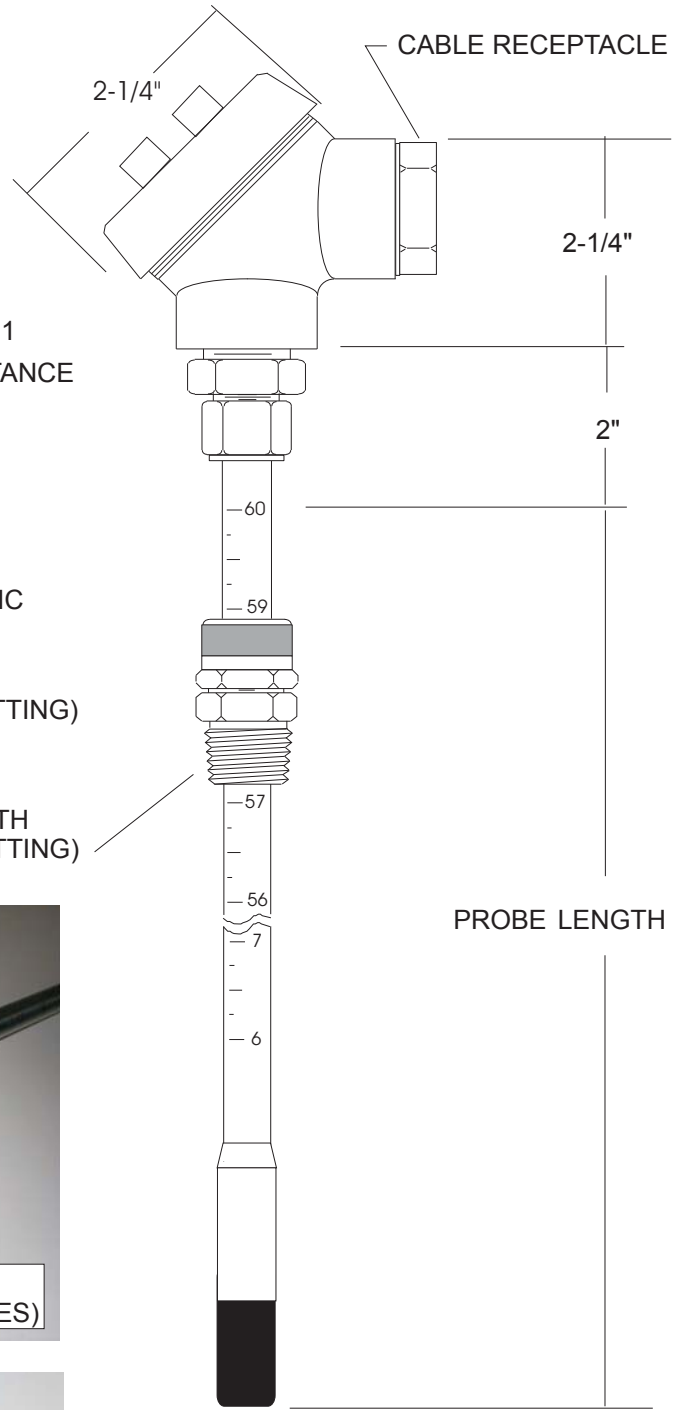

1/2" NPT (3/4" NPT WITH HIGH PRESSURE FITTING)

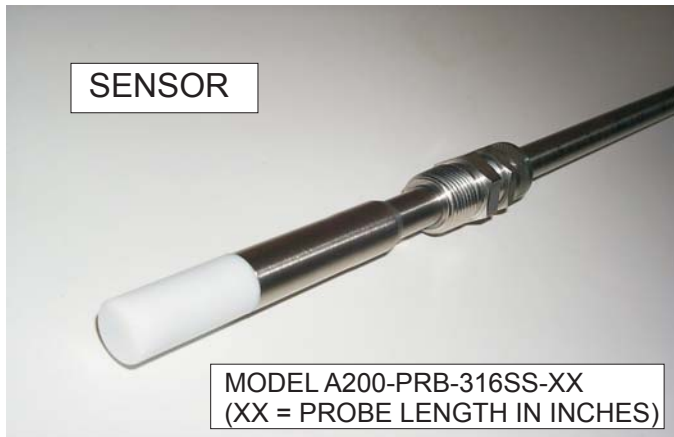

(WILL PASS THRU 1/2" NPT)



INDUSTRIAL FLUID CONTROLS
CINCINNATI, OHIO 45246
(513) 874-8499



JOSEPH SHEFSKY, P.E.

02/12/06

MODEL A-200 LEVEL PROBE, CAPACITANCE SENSOR

DRAWING

20060212-4

REV 2/08

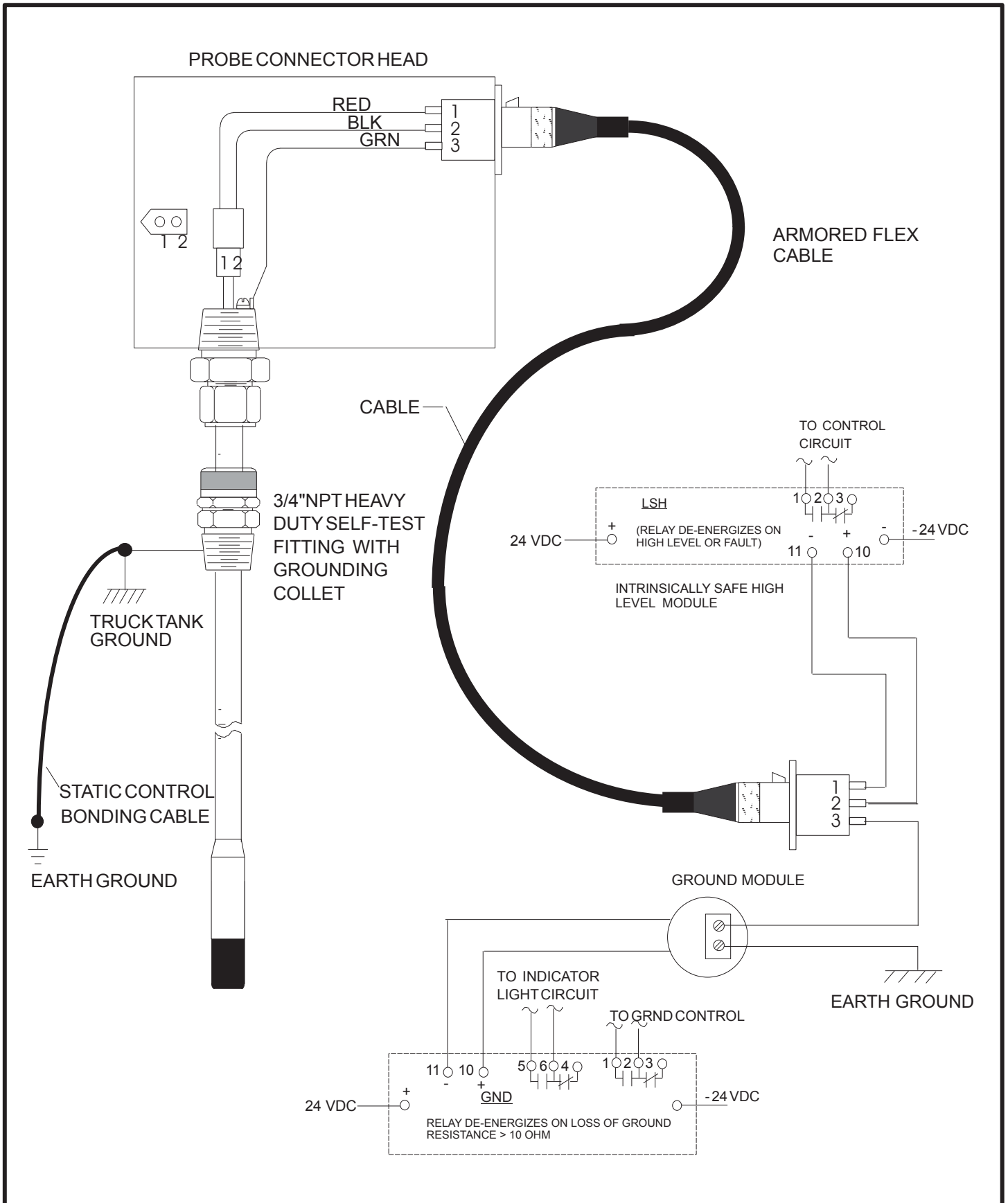

INDUSTRIAL FLUID CONTROLS
CINCINNATI, OHIO 45246
(513) 874-8499



JOSEPH SHEFSKY, P.E.

02/12/06

MODEL A-200 LEVEL/GROUND PROBE
GROUND DETECTION CIRCUIT

DRAWING NO.

20060212-5

REV 02/20/10

INDUSTRIAL FLUID CONTROLS

CINCINNATI, OHIO 45246 (513) 874-8499

dixonvalve.com

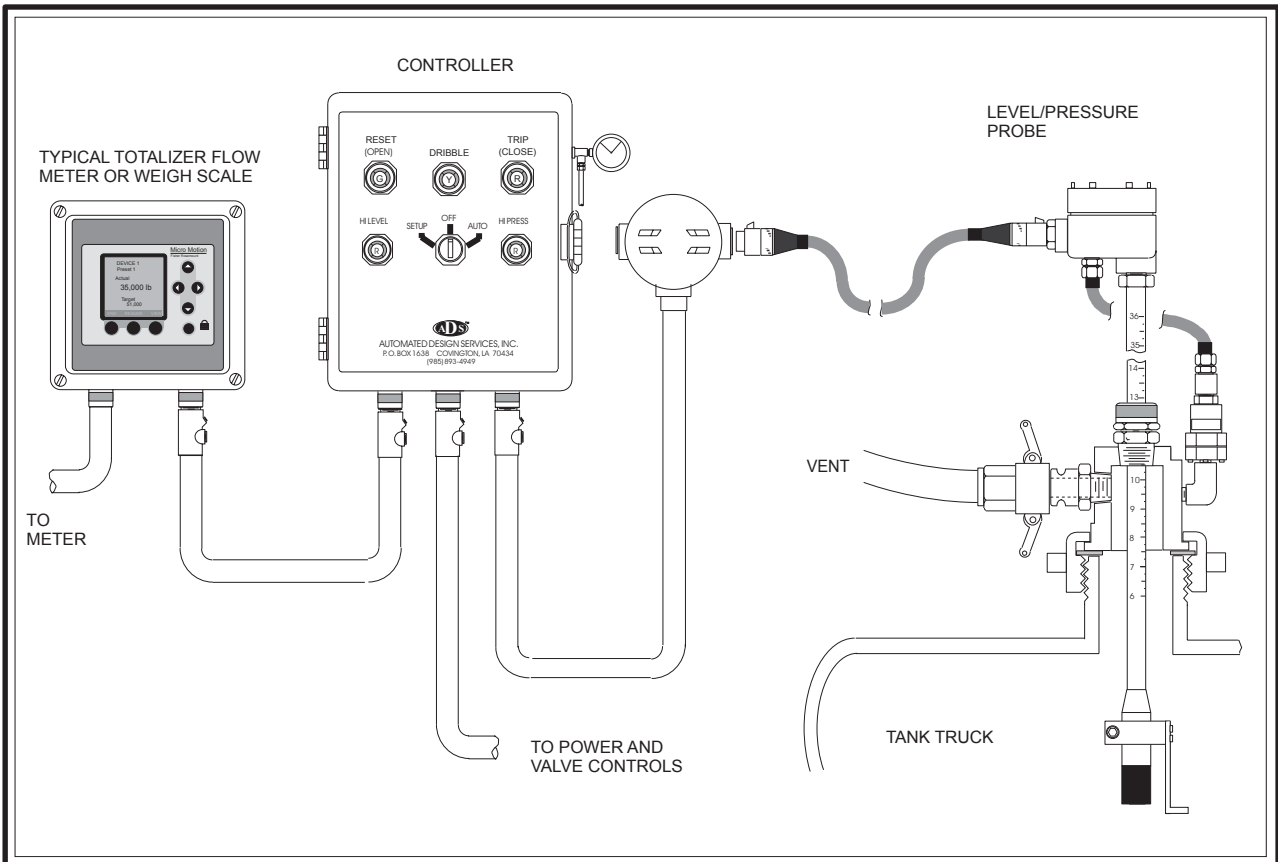

A-300-SP-1000A BATCHGUARD SYSTEM

Manufacturers of liquid level controls for overfill prevention.

- Liquid terminal automation
- Field storage



Model A-300-SP-1000A *Batchguard*[™] Batch Control System. Two mode batch control using external totalizer contact inputs with high level and high pressure trip. Specifically designed for closed dome loading.

FEATURES:

Two-stage (full flow/dribble) level control with fail safe totally independent high level and high pressure override. Easy and friendly operation via heavy duty illuminated push button switches. NEMA 4X enclosure suitable for Div 2 Hazardous areas with customer provided type Z purge. Variable insertion length single point capacitance proximity probe, intrinsically safe for Class I, Div. 1 in conjunction with supplied controller. Probe adapts to vessel via 3" W/O cap with integral vent connection. Probe diameter 1/2" features a laser engraved graduated scale with 1/4" graduations. Rugged, corrosion and solvent resistant cable, protected by a stainless steel interlocking armor sheath with heavy duty latching connectors at both ends. Fail safe design trips in the event an open or shorted cable or loss of power. Powered outputs for 2-stage valve control plus powered outputs for external horn and light.

SPECIFICATIONS:

BATCH CONTROLLER:

- NEMA 4X enclosure suitable for Class I, Div. 2 with type Z purge.
- Accepts solid state or dry contact dribble and trip inputs from flow totalizer and provides Intrinsically Safe sensor drivers for level/ pressure probe.
- Two 115 VAC/10 amp switched outputs connect directly to user's product valve controls and connections are provided to power external status lights.
- FM approved sensor drivers for Class I, Div 1 Hazardous areas.
- Setup-Off-Auto switch and lighted pushbutton switches for reset, trip, and dribble. Setup mode allows setup and testing prior to loading.
- Input power 115 VAC fused at 5 A.

HIGH LEVEL/HIGH PRESSURE SENSOR:

- Capacitance tip sensitive proximity sensor activates when liquid is within 1/4" of tip.
- Insertion length 4" to 60" adjustable. Longer lengths available.
- Wetted materials 316 SS, Teflon. Other materials available.
- Sensor intrinsically safe for Class I, Div 1, Gr. A, B, C, & D Hazardous areas when used in conjunction with supplied FM approved switching amplifiers.
- Probe temperature range -14 to +212 Deg F.
- Probe pressure rating 50 psig with standard fitting.
- All 316 SS pressure switch adjustable range 2-12 psig, incr. Other ranges available. Hermetically sealed switch element with gold contacts.

CABLE:

- Standard cable lengths 15, 25, and 50 Ft. Other lengths available.
- Cable connectors are designed for repeated mating and meet IP-65 environmental specs.

Rev. 3/29/01



INDUSTRIAL FLUID CONTROLS CINCINNATI, OHIO 45246
(513) 874-8499



HAZARDOUS AREA
CLASS I, DIV 2, GR. A, B, C, & D

TYPICAL TOTALIZER FLOW
METER OR WEIGH SCALE

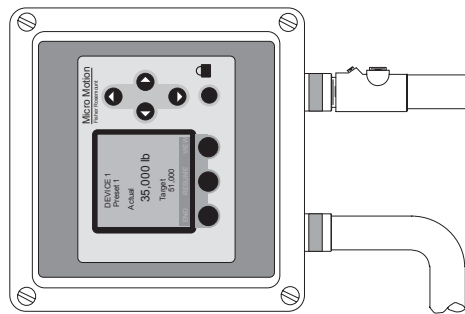

TO
METER

CONTROLLER

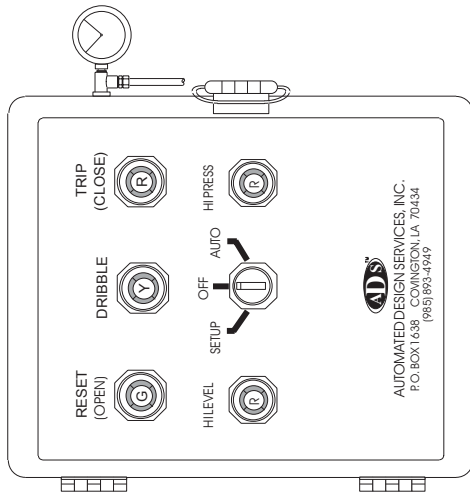

HAZARDOUS AREA
CLASS I, DIV 1, GR. A, B, C, & D

CABLE TERMINATION BOX

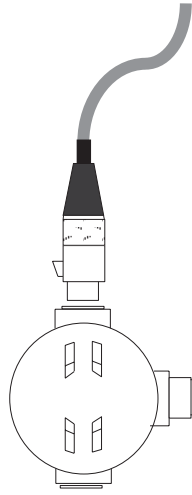

TO PROBE

INTRINSICALLY SAFE WIRING ONLY

TO POWER AND
VALVE CONTROLS



INDUSTRIAL FLUID CONTROLS
CINCINNATI, OHIO 45246
(513) 874-8499



J. SHEFSKY, P. E.
10/20/2000
2 MODEL BATCH CONTROL A300-CTR-SP1000A
MICROMOTION ALTUS TRANSMITTER

DRAWING NO. 2001020-3

REV 7/1701

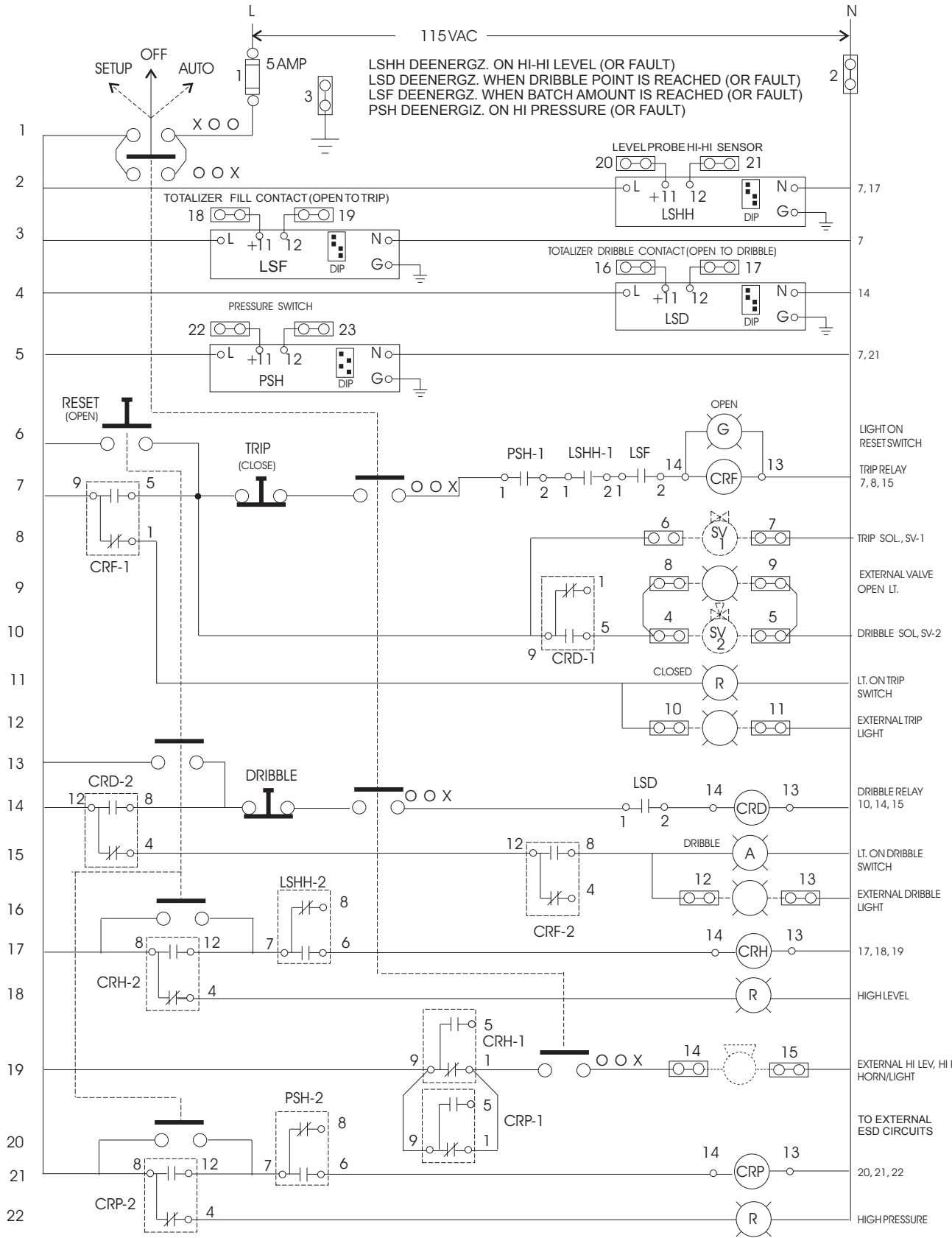

INDUSTRIAL FLUID CONTROLS
 CINCINNATI, OHIO 45246
 (513) 874-8499



JOSEPH SHEFSKY, P.E.

10/20/00

A-300-CTR-SP-1000A SCHEMATIC DIAGRAM

DRAWING NO.

2001020-1

rev 7/11/03

A-300 PROBE WITH LOCATING TAB FOR SETTING OUTAGE, CLOSED DOME

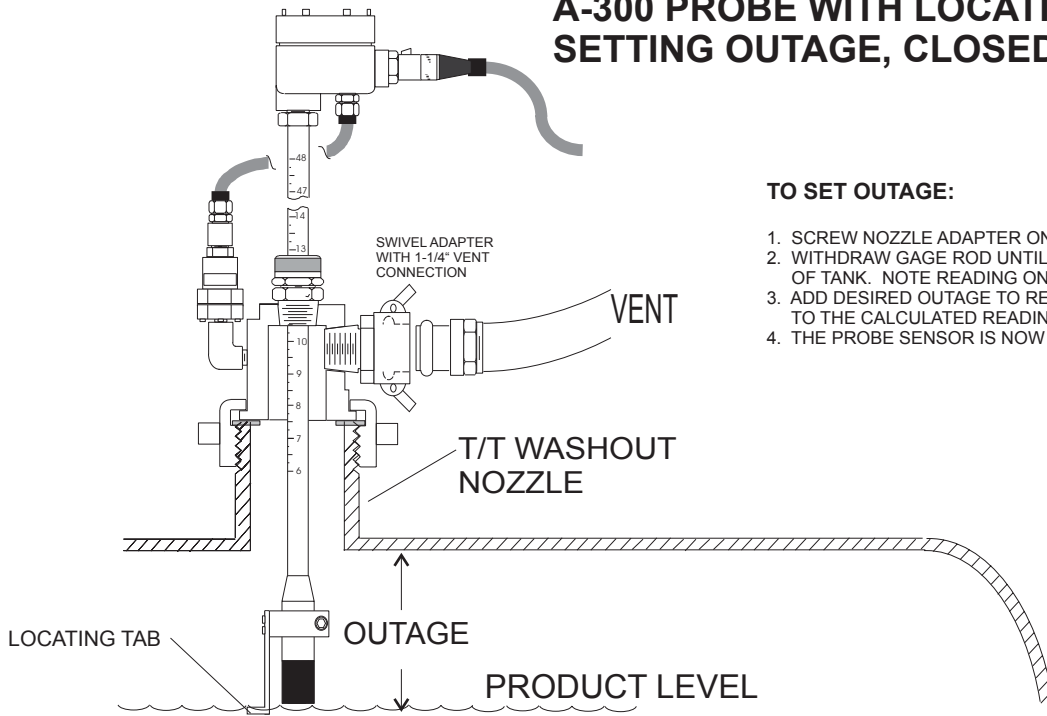

TO SET OUTAGE:

1. SCREW NOZZLE ADAPTER ONTO W/O NOZZLE.
2. WITHDRAW GAGE ROD UNTIL TAB TOUCHES INSIDE SHELL OF TANK. NOTE READING ON ROD.
3. ADD DESIRED OUTAGE TO READING AND PUSH DOWN ROD TO THE CALCULATED READING.
4. THE PROBE SENSOR IS NOW AT THE DESIRED OUTAGE.

EXAMPLE SETTING 10" OUTAGE:

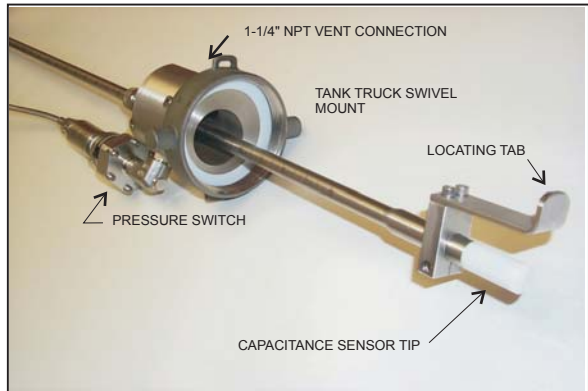

ROD WITHDRAWN
READING 12.5"

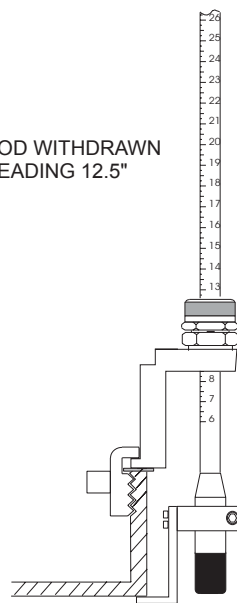

ADD 10" TO READING
(12.5 + 10 = 22.5")
PUSH ROD DOWN TO 22.5"
READING 22.5"

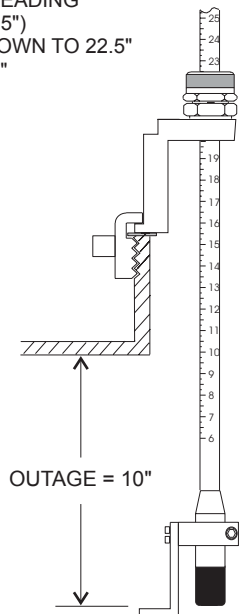

INDUSTRIAL FLUID CONTROLS CINCINNATI, OHIO 45246
(513) 874-8499



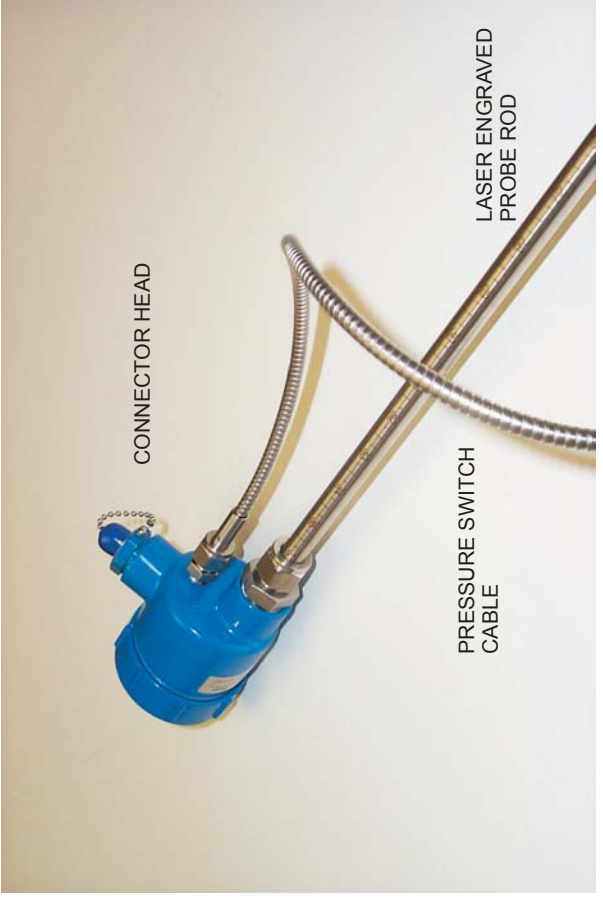
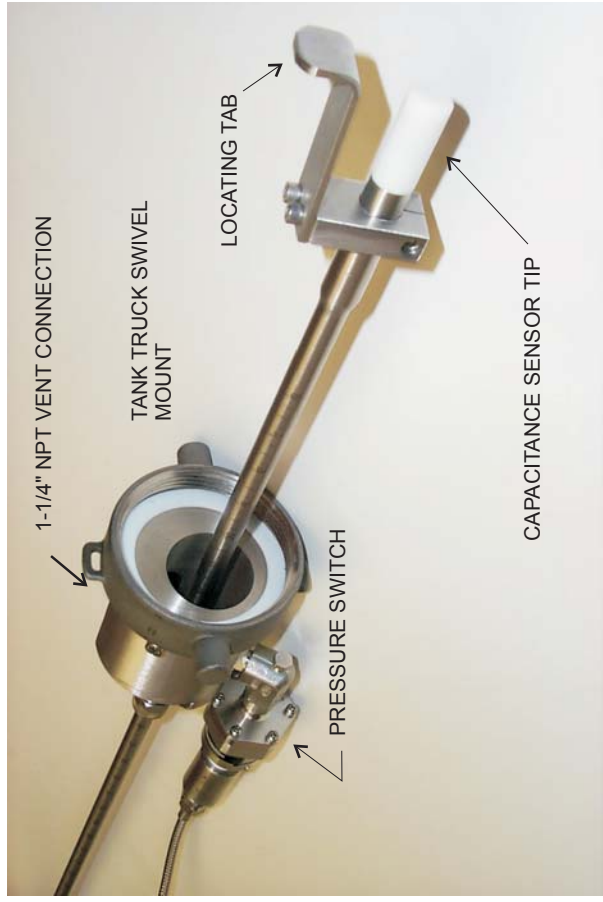
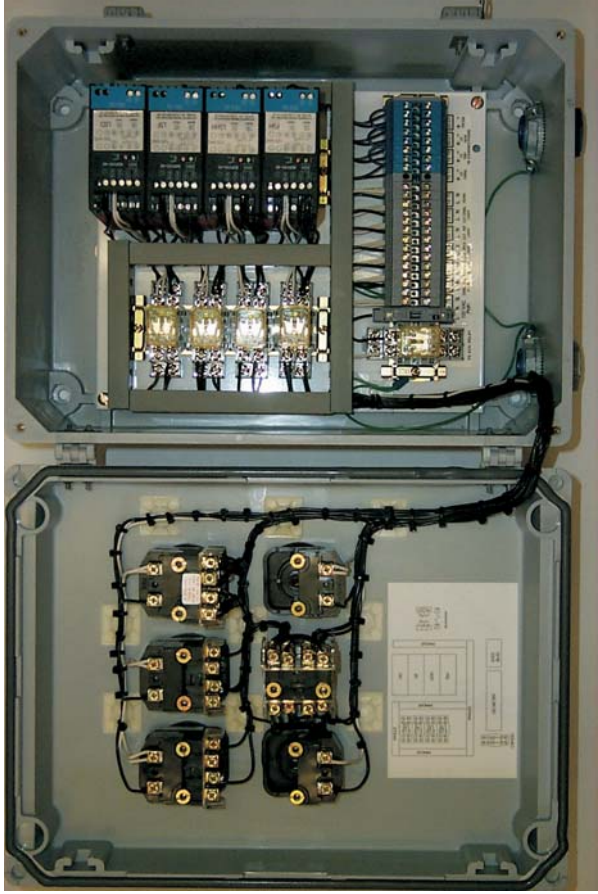
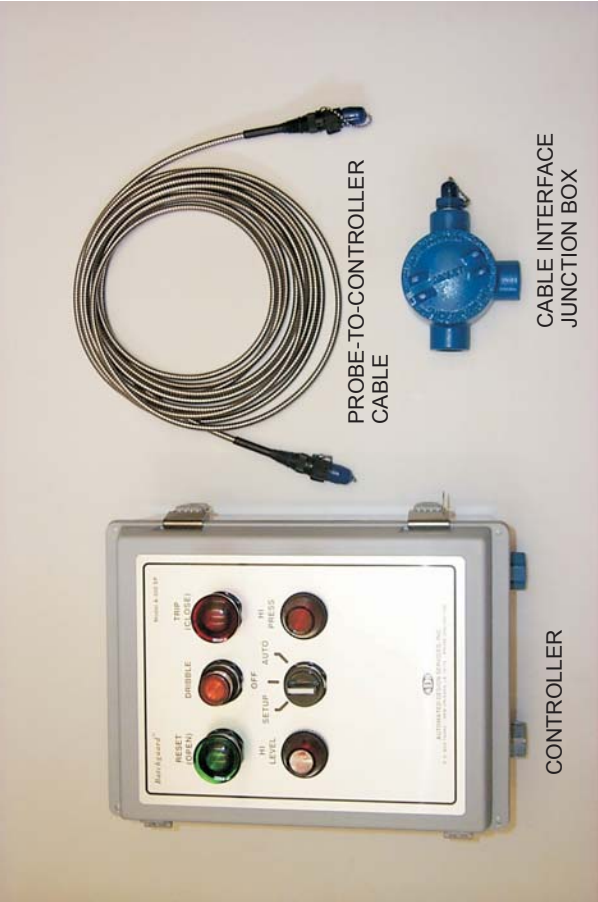

A-300-SP-1000A BATCHGUARD SYSTEM

INDUSTRIAL FLUID CONTROLS

CINCINNATI, OHIO 45246 (513) 874-8499

dixonvalve.com

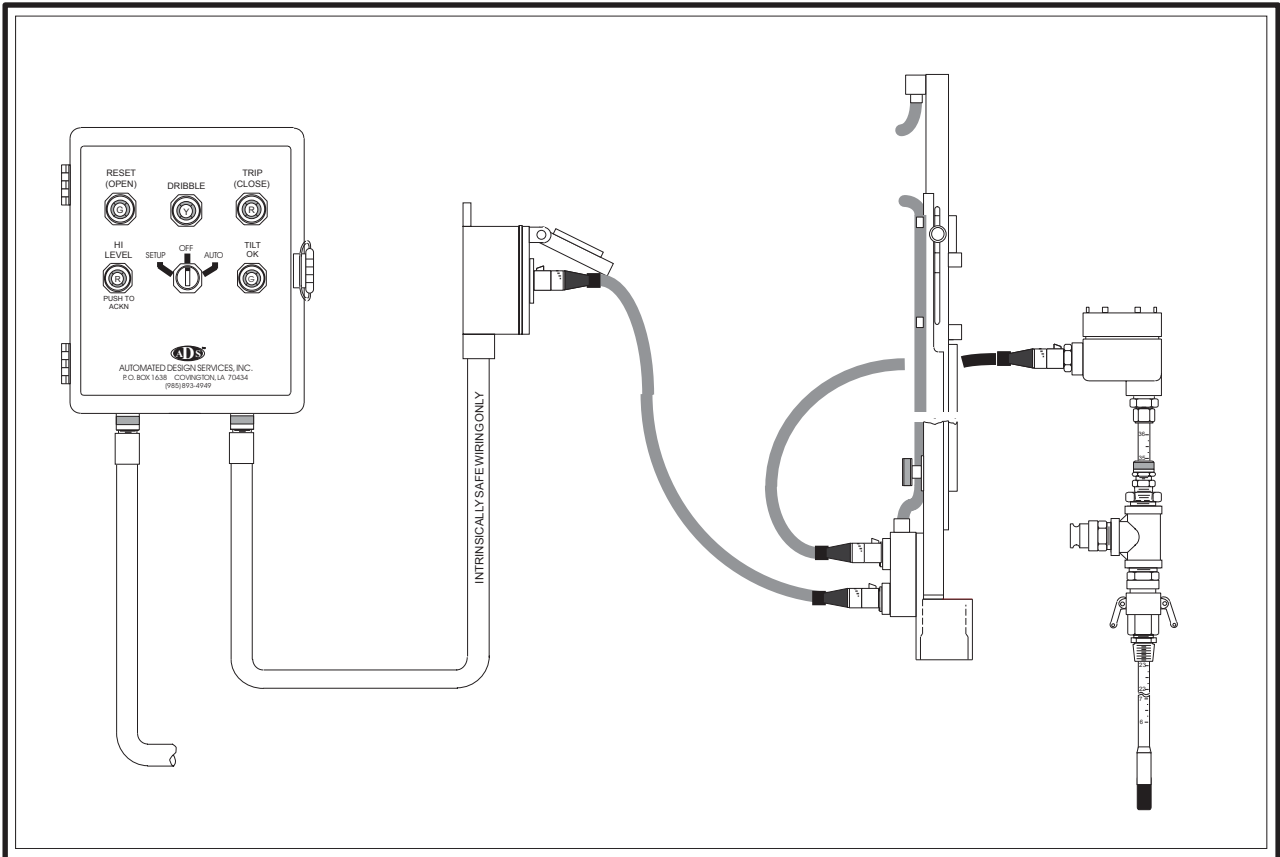

**ADS TANK CAR LOADING SYSTEM WITH DUAL MIDLAND GAGE SENSOR PRIMARY CONTROL AND SINGLE POINT CAPACITANCE SENSOR SECONDARY PROBE
PROJECT SP-0807**

Manufacturers of liquid level controls for overfill prevention.

- Liquid terminal automation
- Field storage

INDUSTRIAL FLUID CONTROLS BATCH LOADING SYSTEM USING MIDLAND B-612 GAGE SENSOR AND CAPACITANCE SECONDARY LEVEL PROBE PROJECT SP0807

SYSTEM COMPRISED OF:

- 1 ea. Midland B-612 gage sensor assy, dual point sensors, Model A300M-SENSOR-SP0807
- 1 ea. Single point capacitance level plus tilt interlock probe, 36" long, Model A200-PRB-LEV-TILT-316SS-36
- 1 ea. Batch controller, Model A300-CTR-SP0807
- 1 ea. Cable connecting Midland sensor to level probe, Model A200-CA-3PIN-5 FT
- 1 ea. Cable connecting controller to Midland gage sensor, Model A200-CA-5PIN-25 FT
- 1 ea. Controller cable receptacle box. Model A200-JB-5PIN
- 1 ea Vapor collection fitting 1" NPT process connection, Model A200-FTG-SP0807

MIDLAND B-610 GAGE SENSOR:

- Non-contact inductive proximity sensors, intrinsically safe for Class 1, Div 1, Gr. A, B, C, D.
- Dual sensors for two stage control..
- Adjustable telescoping stand adjustable from 26" to 60". Dribble/shutoff gap adjustable from 1" to 6".
- Works with all Midland B-612 gages, requires no modification.
- Mounts directly to Midland B-612 2" NPT fitting.

SINGLE POINT CAPACITANCE PROBE PLUS TILT:

- Single point capacitance sensor plus tilt sensor interlock +/- 20 deg off vertical
- 1/2" OD x 36" hardened 316 SS rod with Teflon probe tip, designed for rough handling
- Laser engraved graduated scale on probe.
- Vapor tight sliding fitting.
- 1" male NPT process connections via cam-loc fittings.
- Fail safe on open or shorted cable conductors.
- Max pressure 50 psig, 212 deg F.
- Quick connect cable receptacle.
- Integral vent connection with 1" cam-loc quick connect..
- Intrinsically Safe for Class I, Div 1 Groups A, B, C, D when used with supplied controller..

BATCH CONTROLLER:

- NEMA 4X enclosure suitable for Class I, Div. 2 Hazardous Areas without purge.
- Four discreet Intrinsically safe sensor drivers for Class I, Div 1 Hazardous areas with US and European European regulatory agency approvals.
- Two 115 VAC, 5 amp switched outputs connect directly to user's product valve controls with aux. contacts for pump trip and connections to power external multi-color status indicator beacon light..
- Logic control via hermetically sealed relays
- Powered output to external horn that sounds for 5 seconds at completion of batch, and sounds continuously if trip is due to high level probe requiring manual acknowledge to clear.
- Setup-Off-Auto switch and lighted pushbutton switches for reset, trip, and dribble. Setup mode allows setup and testing prior to loading.
- Long life LED type lamps
- Dribble at termination of batch.
- Input power 115 VAC.

(cont. on next page)



INDUSTRIAL FLUID CONTROLS CINCINNATI, OHIO 45246
(513) 874-8499



**INDUSTRIAL FLUID CONTROLS BATCH LOADING SYSTEM
USING MIDLAND B-612 GAGE SENSOR AND CAPACITANCE
SECONDARY LEVEL PROBE PROJECT SP0807**

Page 2 of 3

CONTROLLER CABLE:

Length 25 ft.
Five conductor quick connect latching connectors at each end.
Stainless steel spiral armor sheath.
Weather and corrosion resistant.
Designed for repeated mating.

MIDLAND GAGE TO PROBE INTERCONNECT CABLE:

Length 5 ft.
Three conductor quick connect latching connectors at each end.
Stainless steel spiral armor sheath.
Weather and corrosion resistant.
Designed for repeated mating.

CONTROLLER CABLE RECEPTACLE BOX:

Corrosion and weather resistant.
5 point terminal block inside.
Spring loaded hinged cover.
IS safety blue..

HAZARDOUS LOCATION STATUS INDICATOR BEACON LIGHT:

3-color LED daylight visible.
100,000 hour, vibration resistant LED source
Approved for Class I, Div 2 Hazardous Areas
12 possible flash/color combinations.
Wires directly to controller



INDUSTRIAL FLUID CONTROLS CINCINNATI, OHIO 45246
(513) 874-8499



**INDUSTRIAL FLUID CONTROLS BATCH LOADING SYSTEM
USING MIDLAND B-612 GAGE SENSOR AND CAPACITANCE
SECONDARY LEVEL PROBE PROJECT SP0807**

OPERATION SEQUENCE

- A Loading operation starts by depressing the Reset (open) pushbutton. This will fully open the product valve and start filling the tank. The tilt switch in the secondary capacitance probe will have to be within +/- 20 degrees from vertical before the valve will open. This is an interlock to make sure that the probe has been properly installed into the fitting on the rail car.
- B When the Midland gage rod reaches the lower sensor, a dribble mode (reduced flow) will be initiated by de-energizing the dribble solenoid valve and the amber light on the dribble switch will go on. When the Midland gage rod reaches the upper sensor, which is the control point, the product valve will go fully closed, the dribble light will go out, and the red light on the trip switch will go on signifying completion of the loading. 5 seconds after trip initiation the external horn will sound for 5 seconds and automatically clear.
- C The operator will be able to push the dribble button to initiate a reduced flow at any time during the loading operation. Pushing the green reset (open) button will restore the flow to full flow. Also, the operator will be able to press the trip switch to stop the loading. Doing so will close the valve and sound the horn for 5 seconds after a 5 sec. delay.. Pushing the green reset (open) button will open the valve and continue the loading.
- D If at any time the level sensor in the tank sees a liquid, the loading valve will close, the horn will sound after a 5 sec. delay, and the red high level lighted push-button will illuminate. Depressing the red ackn. button will silence the horn.

NOTE

If high level comes in within 5 sec. after normal trip, the hi level light will go off and come back on in 5 sec. and remain on until acknowledged.

Built-in logic in the controller will drive the external indicator beacon with the following display sequence:

DISPLAY SEQUENCE

ON POWER-UP	RED
START (VALVE OPEN)	GREEN
LEVEL -3" TO 0", DRIBBLE MODE	AMBER
TRIP BY PRIMARY MIDLAND SENSOR	RED STEADY
TRIP BY SECONDARY CAPACITANCE PROBE	RED FLASHING



HAZARDOUS AREA

CLASS I, DIV 2, GR. A, B, C, & D

CLASS I, DIV 1, GR. A, B, C, & D

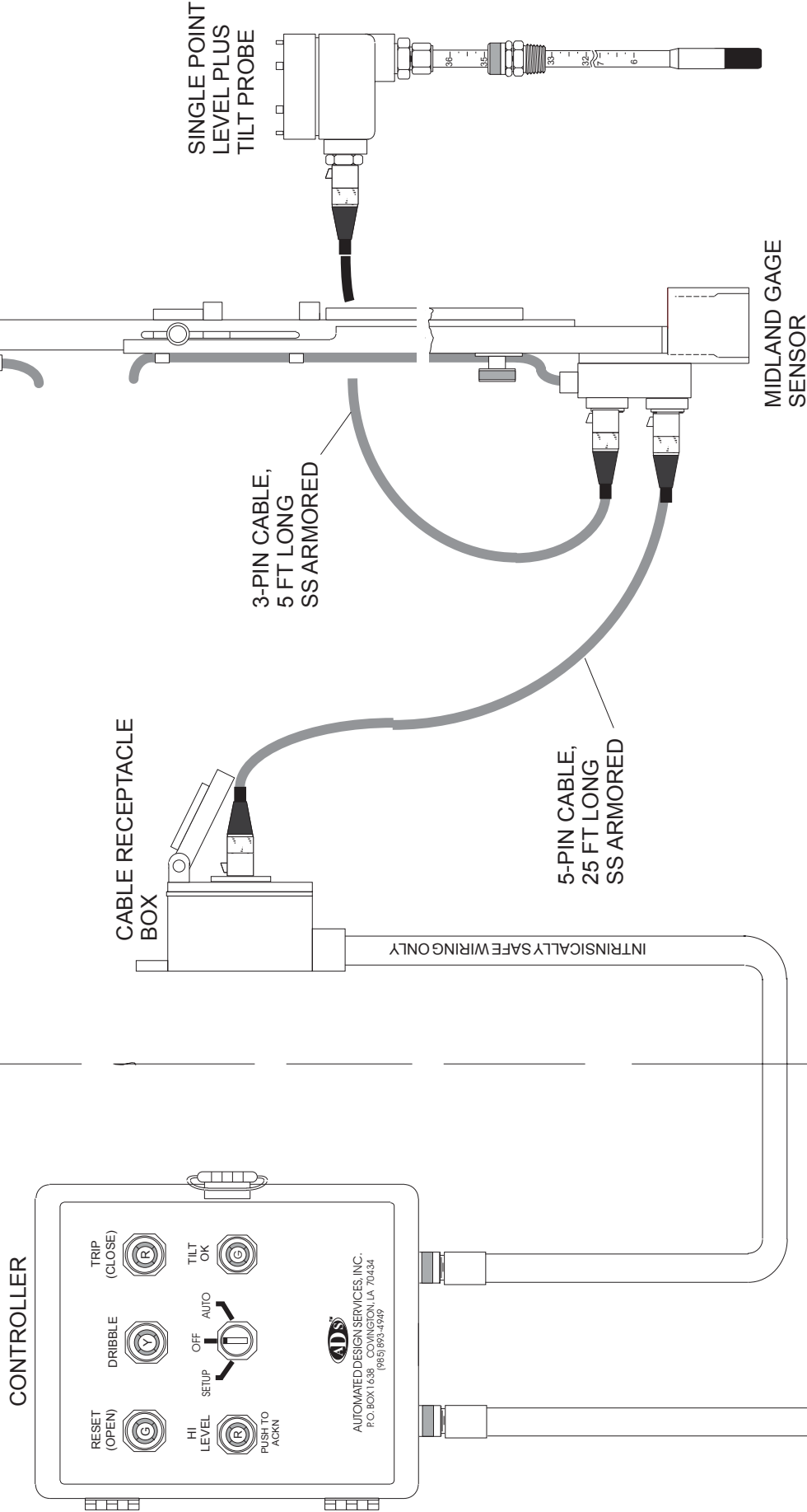

	INDUSTRIAL FLUID CONTROLS CINCINNATI, OHIO 45246 (513) 874-8499		JOSEPH SHEFSKY, P.E.	06/26/2007
BATCH LOADING SYSTEM MIDLAND B-612 GAGE SENSOR PRIMARY CONTROL WITH CAPACITANCE LEVEL PROBE FOR HIGH LEVEL PLUS TILT OVERRIDE		DRAWING NO.	20070626-2	REV 082407

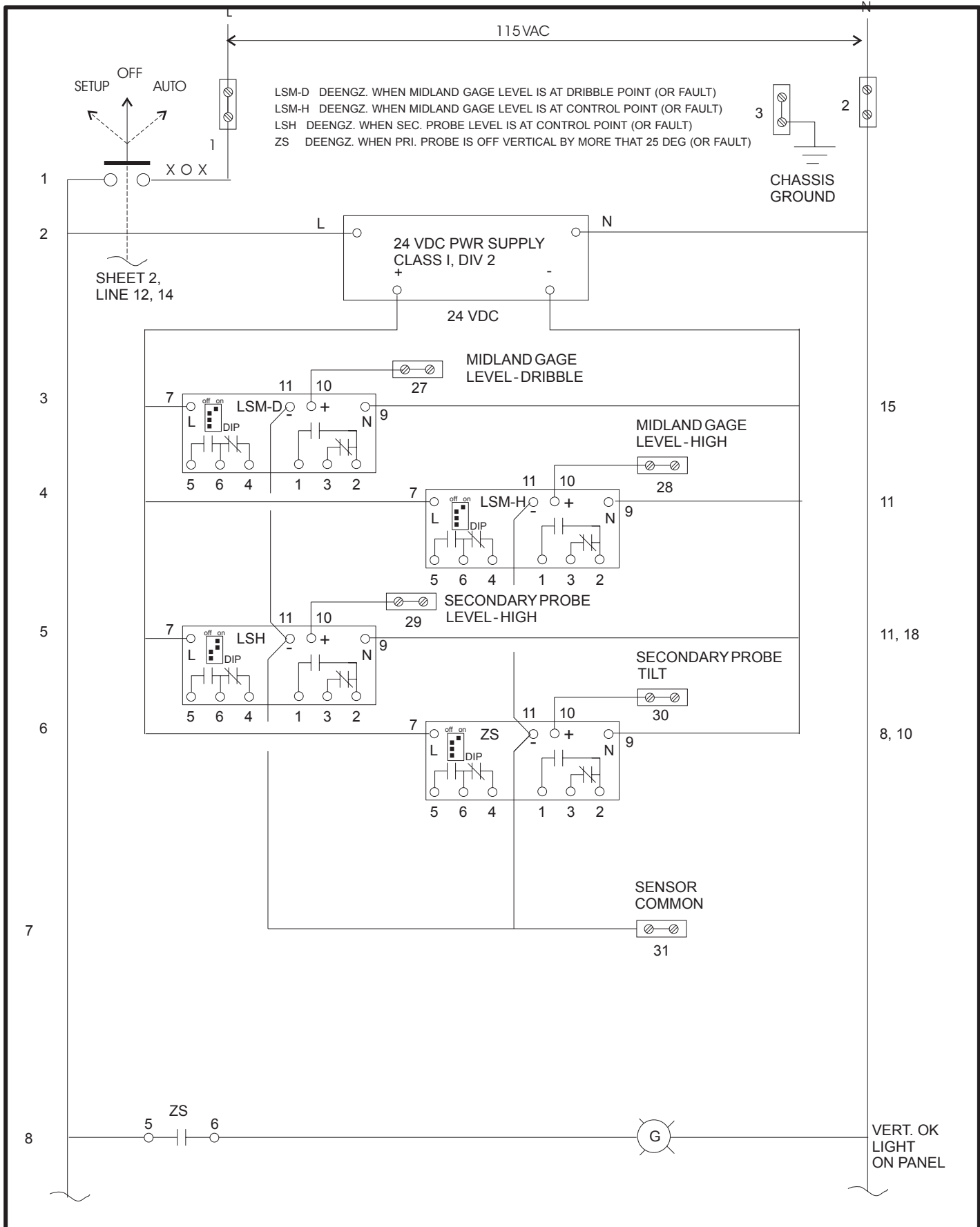

INDUSTRIAL FLUID CONTROLS
CINCINNATI, OHIO 45246
(513) 874-8499



JOSEPH SHEFSKY, P.E.

09/09/07

A300-CTR-SP0807 CONTROLLER
SCHEMATIC DIAGRAM

SH 1 OF 3

DRAWING NO.

20070909-1-1

REV 11/05/07

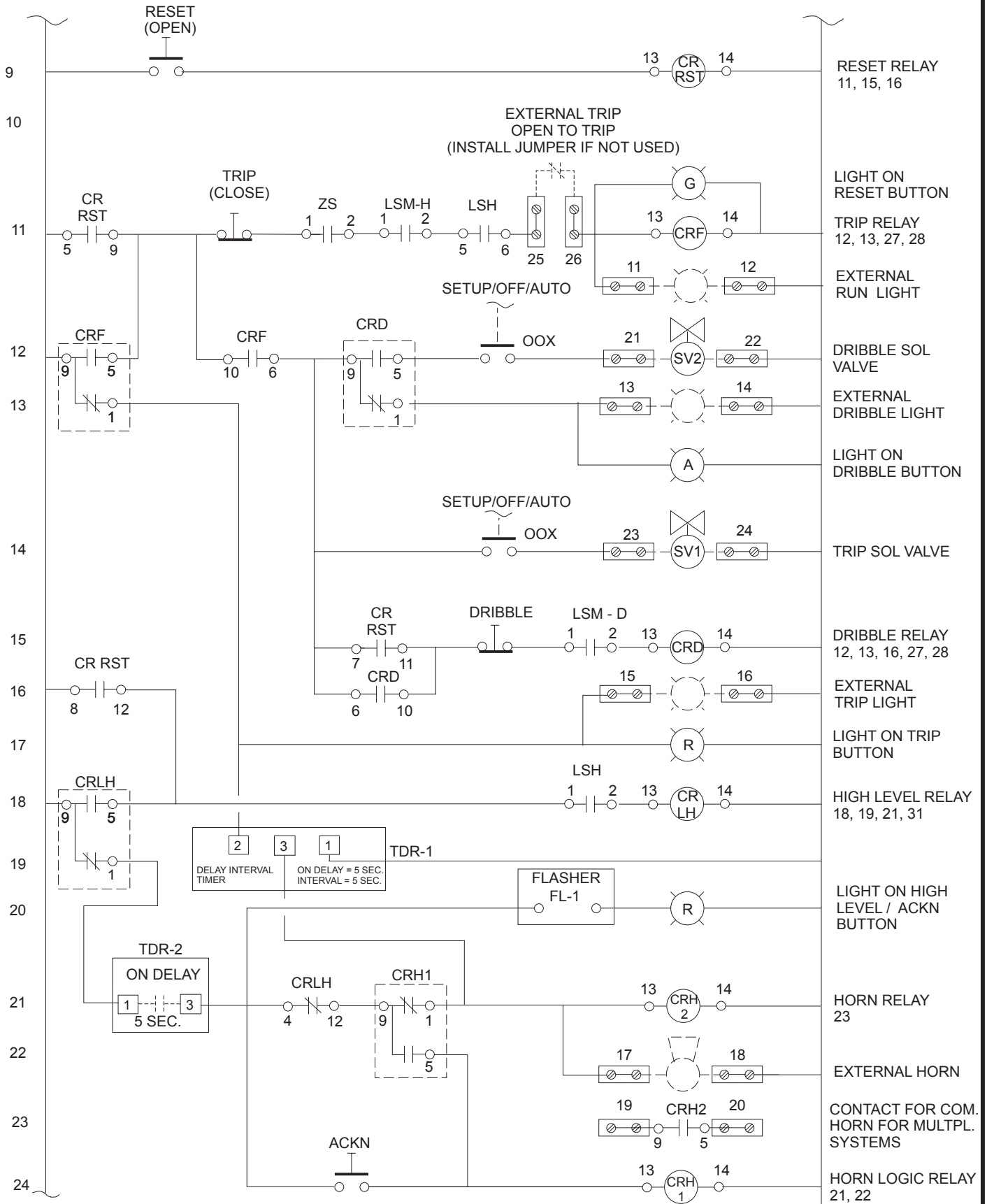

INDUSTRIAL FLUID CONTROLS
 CINCINNATI, OHIO 45246
 (513) 874-8499



JOSEPH SHEFSKY, P.E.

09/09/07

A300-CTR-SP0807 CONTROLLER
 SCHEMATIC DIAGRAM

SH 2 OF 3

DRAWING NO.

20070909-2

REV 11/05/07

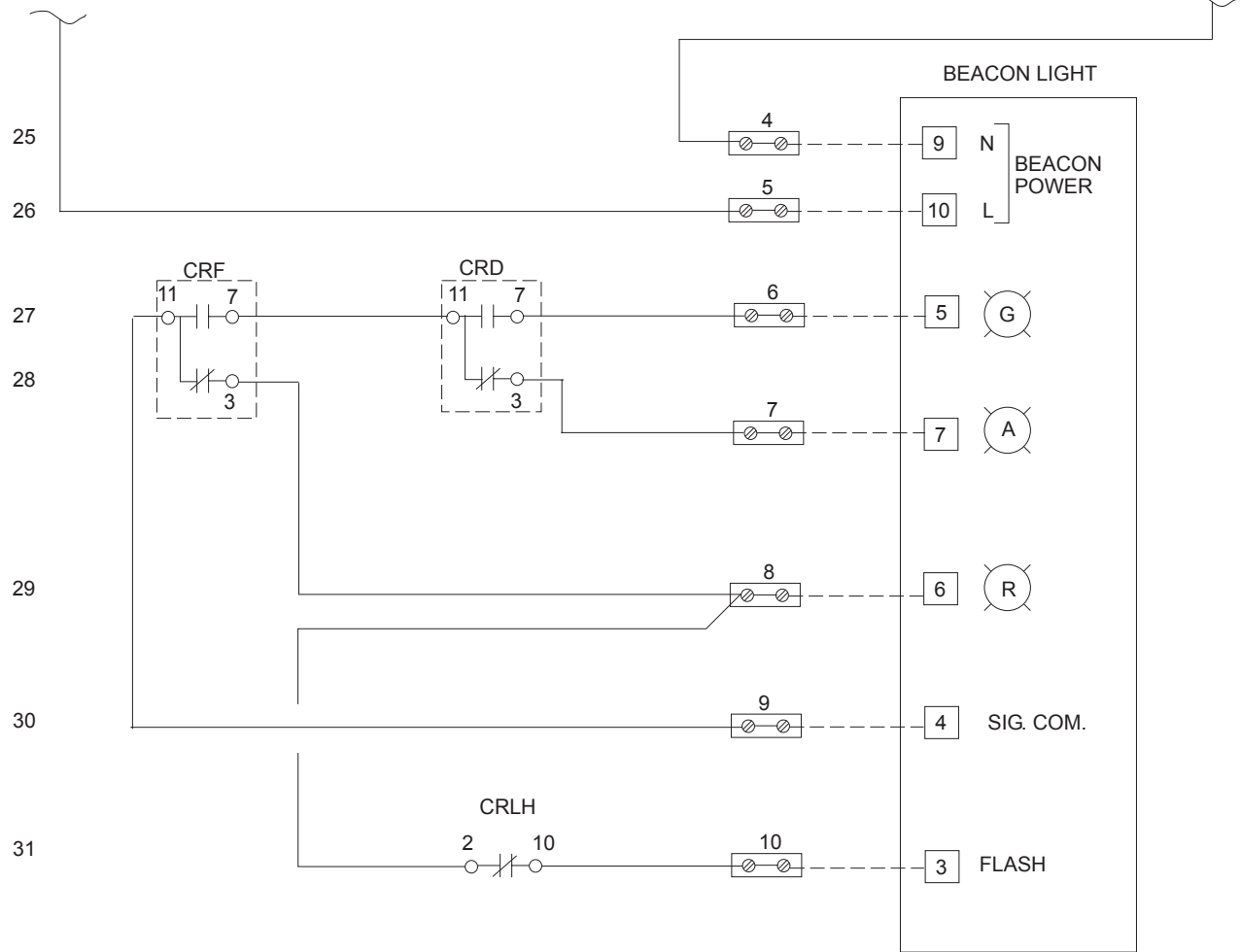

BEACON LIGHT FEDERAL SIGNAL MODEL USIX-120TC, MULTICOLOR LED FOR DIV. 2 HAZARDOUS AREAS, 3 COLORS, RED, AMBER, AND GREEN.

DISPLAY SEQUENCE

ON POWER-UP	RED FLASH
START (VALVE OPEN)	GREEN
DRIBBLE BY MIDLAND	AMBER
TRIP BY MIDLAND	RED
TRIP BY LSH	RED FLASH



INDUSTRIAL FLUID CONTROLS
CINCINNATI, OHIO 45246
(513) 874-8499



JOSEPH SHEFSKY, P.E.

09/09/07

A300-CTR-SP0807 CONTROLLER
SCHEMATIC DIAGRAM

SH 3 OF 3

DRAWING NO.

20070909-3

REV 11/05/07

1	PWR	L
2		N 120VAC
3		G
4	BEACON LIGHT	9N
5		10L
6		5G
7		7A
8		6R
9		4 SIG. COM.
10		3 FLASH
11	L N	EXT. RUN LIGHT
12		
13	L N	EXT. DRIBBLE LIGHT
14		
15	L N	EXTERNAL TRIP LIGHT
16		
17	L N	EXTERNAL HORN
18		
19	HORN DRY CONTACT (N.O.)	
20		
21	L N	DRIBBLE SOL. VALVE
22		
23	L N	TRIP SOL. VALVE
24		
25	EXTERNAL TRIP OPEN TO TRIP (INSTALL JUMPER IF NOT USED)	
26		
27	PROBE	LSM-D
28		LSM-H
29		LSH
30		ZS
31		COM.



INDUSTRIAL FLUID CONTROLS
CINCINNATI, OHIO 45246
(513) 874-8499



JOSEPH SHEFSKY, P.E.

09/09/07

A300-CTR-SP0807 CONTROLLER
TERMINAL BOARD WIRING

DRAWING NO.

20070909-4

REV 11/05/07

MIDLAND SENSOR

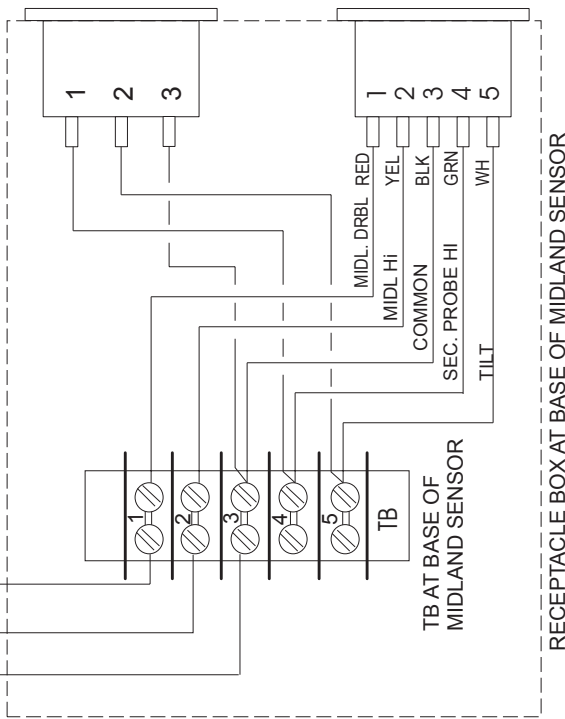
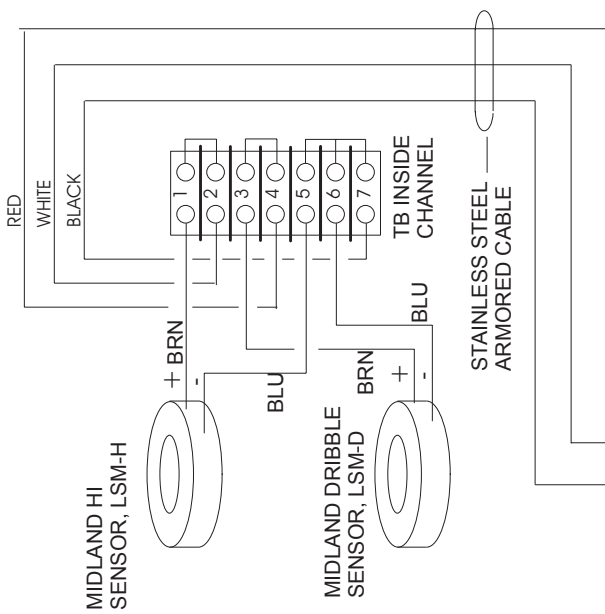

SECONDARY PROBE CONNECTOR HEAD

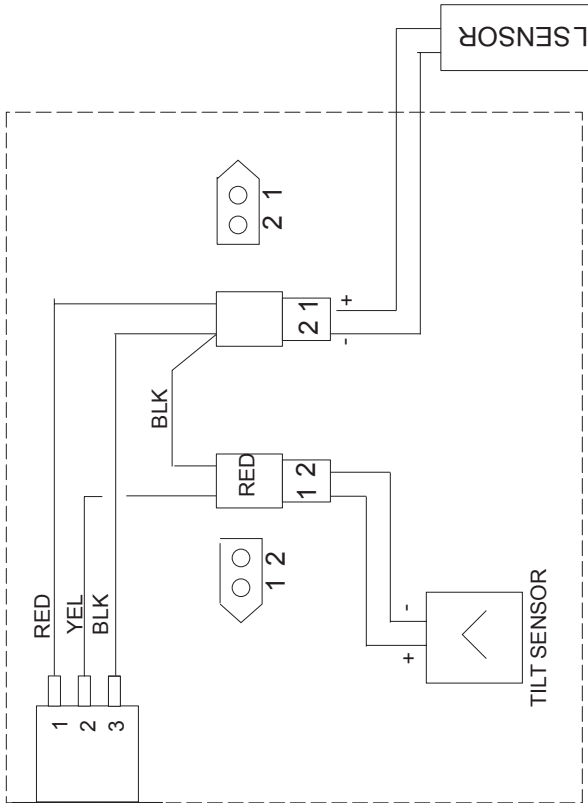

FIELD WIRING

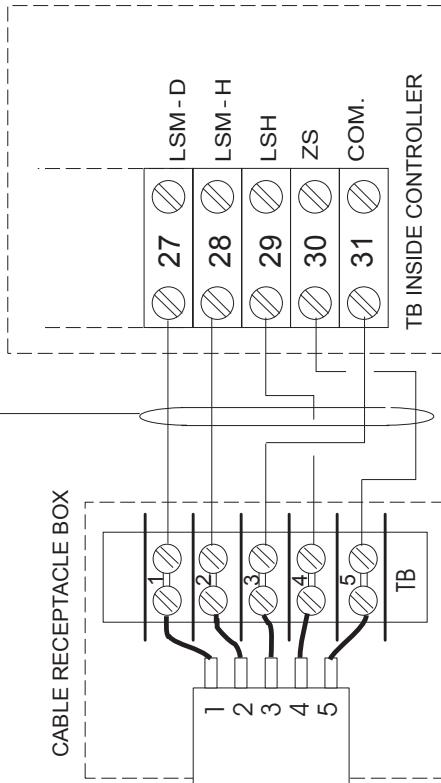

INDUSTRIAL FLUID CONTROLS
CINCINNATI, OHIO 45246
(513) 874-8499



JOSEPH SHEFSKY, P.E. 03/01/06
A300-SP0807 MIDLAND SYSTEM SENSOR
TO CONTROLLER WIRING DIAGRAM
DRAWINGNO. SK-110607-3

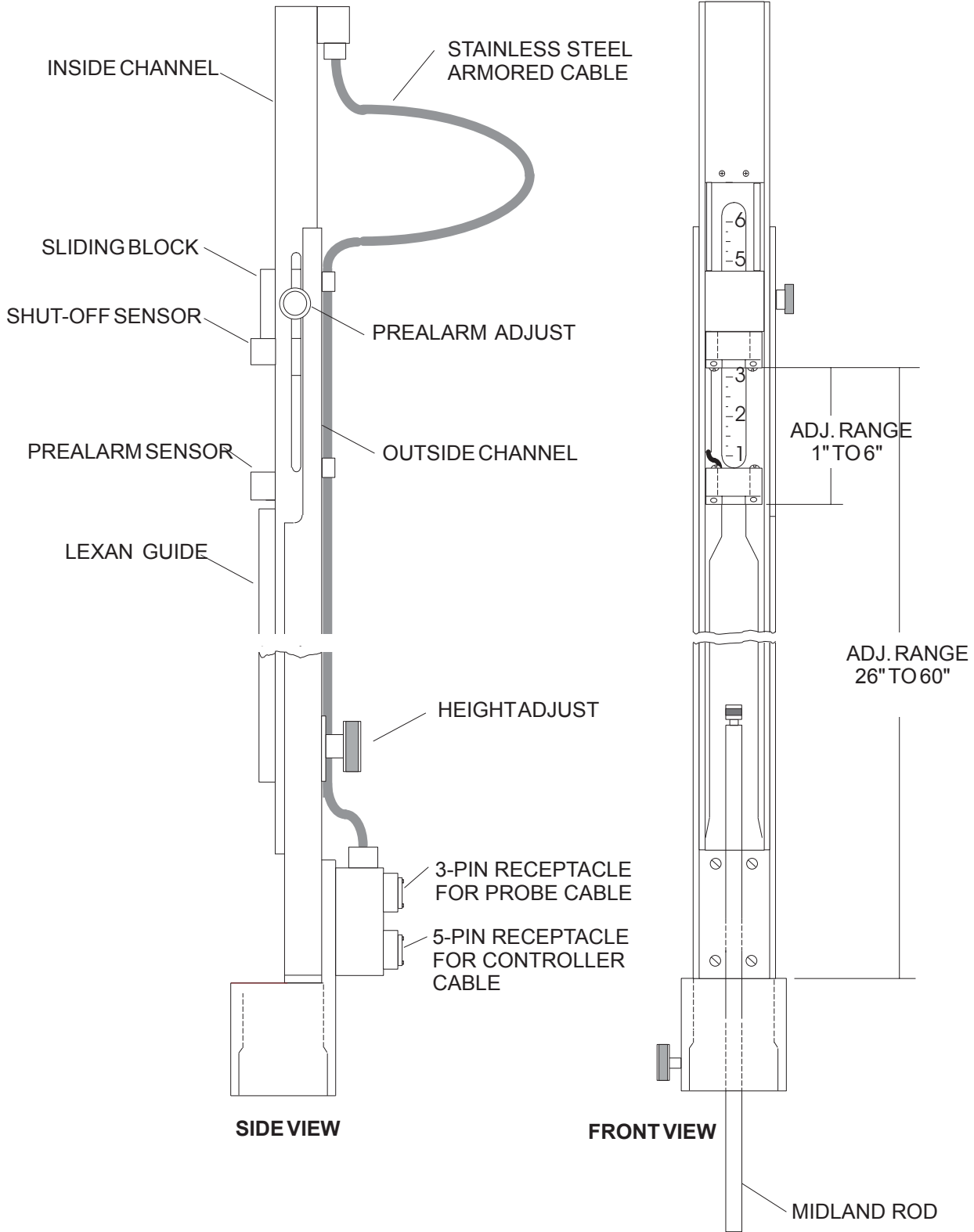

INDUSTRIAL FLUID CONTROLS
 CINCINNATI, OHIO 45246
 (513) 874-8499

JOSEPH SHEFSKY, P.E.

6/26/07

MIDLAND B-612 GAGE ROD DETECTOR,
 2-POINT WITH RECEPTACLE FOR SECONDARY
 PROTECTION LEVEL PROBE

DRAWING NO.

20070626-1

- INTRINSICALLY SAFE DESIGN, CLASS I, DIV 1
- RUGGED, RELIABLE TIP SENSITIVE CAPACITANCE SENSOR.
- TILT SWITCH INTERLOCK, VIBRATION RESISTANT
- MAX TEMPERATURE, 212 DEG F MAX
- WETTED MATERIAL 316 SS AND TEFLON™
- GRADUATED ROD, LASER ENGRAVED.
- VARIABLE INSERTION LENGTH
- WORKS WITH ANY LIQUID WITH A DIELECTRIC CONSTANT OF 1.8 OR GREATER.
- NO CALIBRATION REQUIRED.
- MAX PRESSURE 50 P (300 P HIGH PRESS FITTING)
- LOW CURRENT DRAW, 0.50 MA AT 5 VDC.

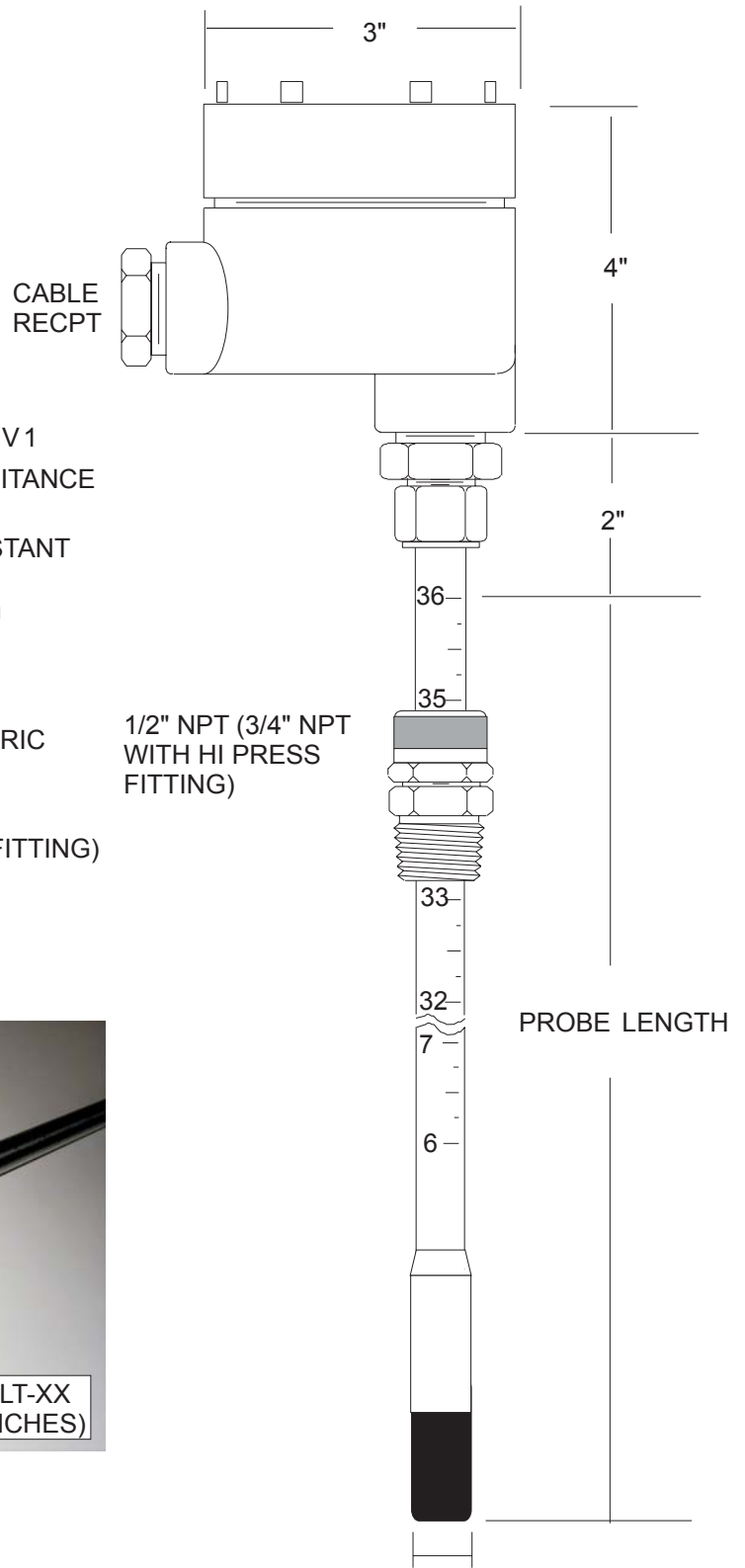
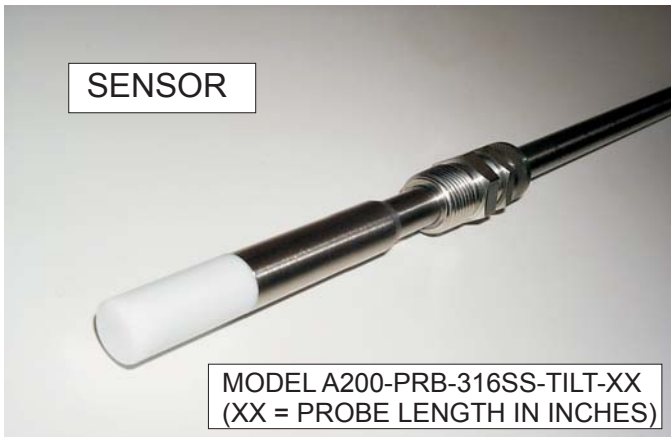

1/2" NPT (3/4" NPT WITH HI PRESS FITTING)

(WILL PASS THRU 1/2" NPT)



INDUSTRIAL FLUID CONTROLS
CINCINNATI, OHIO 45246
(513) 874-8499



JOSEPH SHEFSKY, P.E.

9/12/07

SECONDARY PROBE, CAPACITANCE LEVEL
SENSOR PLUS TILT INTERLOCK

DRAWING

2007912-1

INDUSTRIAL FLUID CONTROLS

CINCINNATI, OHIO 45246 (513) 874-8499

dixonvalve.com

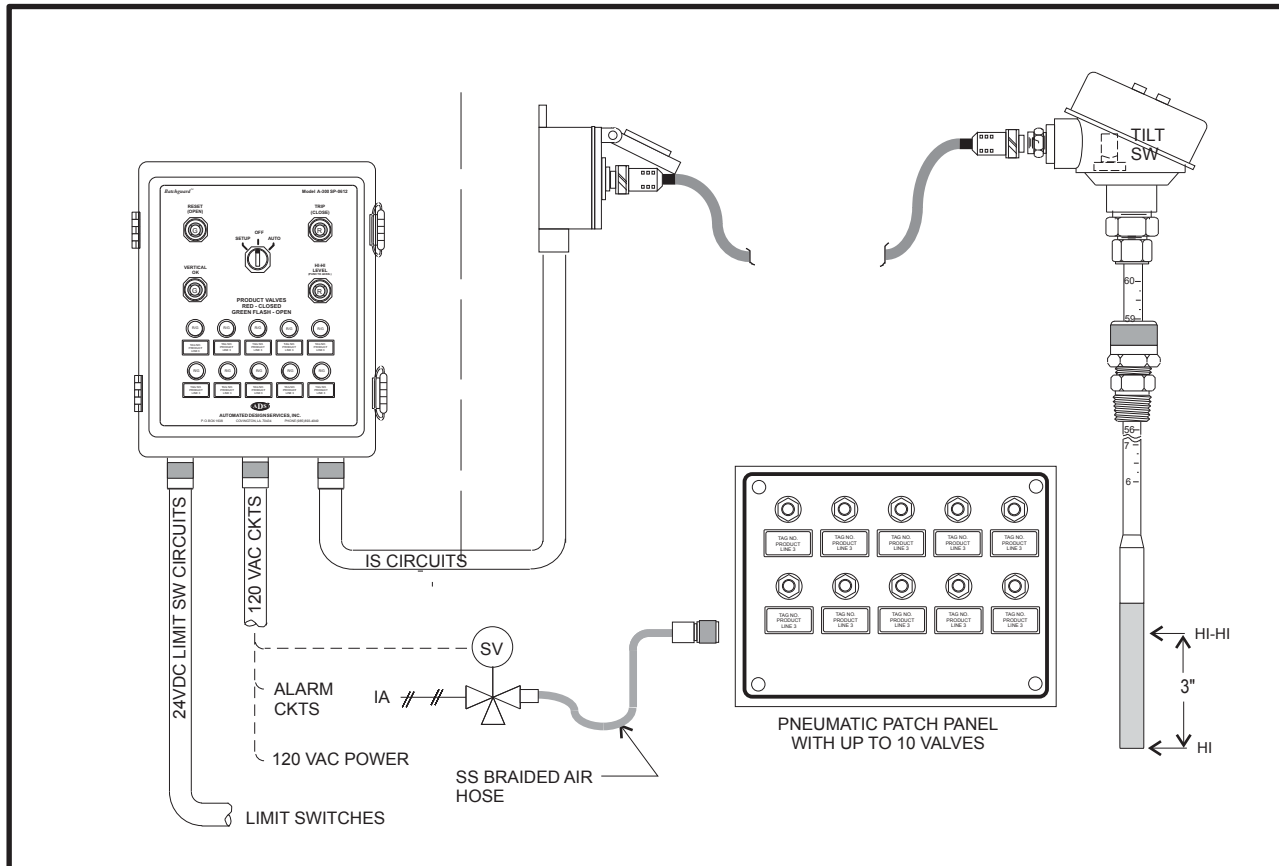

**TANK CAR LOADING SYSTEM PROPOSAL FOR DOW CHEMICAL TEXAS CITY
FEATURES AND SPECIFICATIONS
A300-SP0612**

Manufacturers of liquid level controls for overfill prevention.

- Liquid terminal automation
- Field storage

TANK CAR LOADING SYSTEM PROPOSAL FOR DOW CHEMICAL TEXAS CITY FEATURES AND SPECIFICATIONS A300-SP0612

Page 1

SYSTEM COMPRISED OF:

- 24 ea. All 316 SS 2-point level plus tilt probe.
- 24 ea. Batch controller with lighted pushbuttons and lights
- 24 ea. Controller-to-probe cable
- 24 ea. Controller cable receptacle box
- 24 ea. Product select pneumatic patch panel

PROBE:

- 2-point level with tilt interlock, 316 SS.
- 3/4" OD x 60" long, designed for rough handling.
- Switch points at control point, and 3" above control point
- Laser engraved graduated scale on probe.
- Tilt switch requires probe to be within +/- 20 deg of vertical for the system to reset
- Vapor tight sliding fitting.
- 3/4" male NPT process connections.
- The 2 sensors are totally independent and are fail safe (indicate high) on open or shorted cable conductors.
- Max pressure 50 psig, 250 deg F.
- Intrinsically Safe for Class I, Div 1 Groups A, B, C, D when used with supplied controller.

BATCH CONTROLLER:

- NEMA 4X enclosure with hermetically sealed switches and relays; and lights and timers suitable for Class I, Div. 2 without type Z-purge.
- Intrinsically safe FM approved sensor drivers for Class I, Div 1 Hazardous areas.
- Two level inputs plus electronic tilt switch with built-in time delay to eliminate chatter.
- 115 VAC/5 amp switched output connects directly to user's product valve controls. Connections are provided to power external status lights.
- Accepts external emergency trip switch inputs.
- 5 second self clearing horn blast at loading completion via LSH
- Continuous horn blast if loading completion via LSHH, silenced by acknowledge button
- Setup-Off-Auto switch and lighted pushbutton switches for reset, trip, and acknowledge. Setup mode allows setup and testing prior to loading.
- Open/Closed indication for each product valve via lights on front panel. Up to 10 valves, indication only.
- Green flash "open", red steady "closed".
- Power source 115 VAC/ 5 amp. User to supply circuit protection.

PROBE-TO-CONTROLLER CABLE:

- Industry standard mini-change 5/C rubber insulated cable with M/F connectors
- Screw on connectors with dust caps at each end.
- Weather and corrosion resistant rated IP-65
- Designed for repeated mating.

CONTROLLER CABLE RECEPTACLE BOX:

- Corrosion and weather resistant
- 5 point terminal block inside.
- Spring loaded hinged cover.
- IS safety blue.

Rev 032313



INDUSTRIAL FLUID CONTROLS CINCINNATI, OHIO 45246
(513) 874-8499



**TANK CAR LOADING SYSTEM PROPOSAL FOR DOW CHEMICAL TEXAS CITY
FEATURES AND SPECIFICATIONS
A300-SP0612**

Page 2

PRODUCT SELECT PNEUMATIC PANEL:

Select any one of up to 10 product valves.
Quick connect couplings. Female hose end coupling is valved shut when not plugged in.
Male bulkhead panel end couplings are vented and have captive dust caps.
Panel couplings have 3/8" dual ferrule tubing connections.
Panels are 1/4" stainless steel that will mount to a user supplied Unistrut frame.
Removable metallized custom product labels supplied as 1, 2, 3 ... 10.
Each panel comes with a single 3 ft.316 SS braided hose with 1/4" male NPT connector at one end and a valved female quick disconnect with a captive dust cap at the other end.
Approx size 12" x 15".

ITEMS NOT INCLUDED::

Horns
External lights
Solenoid valves

Rev 032313



INDUSTRIAL FLUID CONTROLS CINCINNATI, OHIO 45246
(513) 874-8499



TANK CAR LOADING SYSTEM PROPOSAL FOR DOW CHEMICAL TEXAS CITY FEATURES AND SPECIFICATIONS A300-SP0612

Page 3

CONTROL SEQUENCE

ON POWER-UP IN SET-UP OR AUTO:

Control solenoid valve de-energized, Valve is closed.

Red light on "TRIP (CLOSE)" push button switch will be on.

If "RESET" is not pressed within 5 seconds of power up, the horn will sound for 5 seconds, then clear. After another 5 seconds the horn will resound and the red HI-HI level (PUSHTO ACKN) light will flash.

Pressing the ACKN button will silence the horn and stop the flash. Pressing the "RESET" button will also silence the horn and start the loading operation.

-NOTE-

The tilt interlock will prevent the system from being reset unless the probe is within +/- 20 degrees of vertical

START LOADING:

Pushing the RESET (OPEN) push button will open the selected product valve.

The TRIP (CLOSE) light will go out and the green RESET (OPEN) light will go on.

The valve will remain open until the LSH sensor detects a liquid. At that time the valve will close, the red TRIP(CLOSE) light will go on, the green RESET (OPEN) light will go out. Then after a 5 second delay the horn will sound for 5 seconds and clear.

ABNORMAL TRIP:

If for some reason the primary LSH does not work, a totally independent LSHH at a point 3" above the LSH point will trip the valve closed, turn on the horn after a 5 second delay and flash the HI-HI LEVEL (PUSH TO ACKN.) push button. The horn will continue to sound and the light will flash until the HI-HI LEVEL (PUSH TO ACKN.) push button is pressed by the operator, which will silence the horn and stop the flash. The HI-HI level will continue to glow steady as long as the high LSHH sensor remains wetted.

If the system is tripped via the optional external trip contact, the valve will close, and the horn and light sequence will be the same as a normal trip.

SET-UP MODE:

The control sequence described above also applies in the set-up mode, **with the exception that the solenoid valve will always remain de-energized**. This mode is for set up and testing the functionality of the system.

Rev 032313



INDUSTRIAL FLUID CONTROLS CINCINNATI, OHIO 45246
(513) 874-8499



HAZARDOUS AREA
CLASS I, DIV 2, GR. A, B, C, & D

HAZARDOUS AREA
CLASS I, DIV 1, GR. A, B, C, & D

CONTROLLER

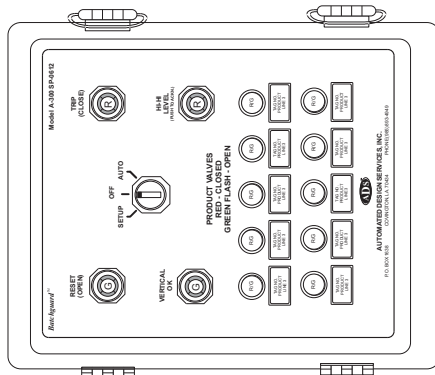

CABLE
TERMINATION
BOX

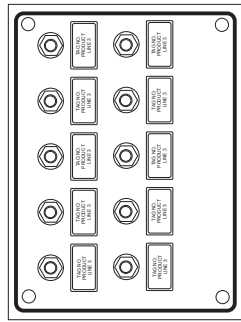

PNEUMATIC PATCH
PANEL WITH UP TO
10 VALVES

IS CIRCUITS

24VDC LIMIT SW CIRCUITS

120 VAC CKTS

ALARM
CKTS

120 VAC POWER

LIMIT SWITCHES

SV

IA

SS BRAIDED AIR
HOSE, 3 FT.

HI-HI ←
3" →
HI →

SLIDING GLAND
→ TO PRODUCT
VALVES BY USER

3/4" NPT

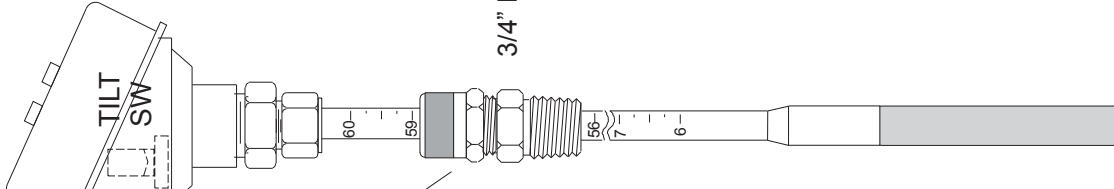

INDUSTRIAL FLUID CONTROLS
CINCINNATI, OHIO 45246
(513) 874-8499



J. SHEFSKY, P. E.

BATCH CONTROL SYSTEM WITH DUAL-POINT
INDEPENDENT CAPACITANCE SENSORS

DRAWINGNO.

SK061512-1

REV 032313

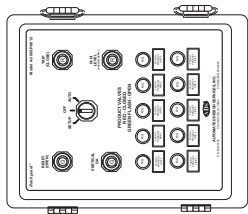
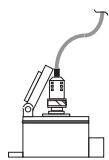
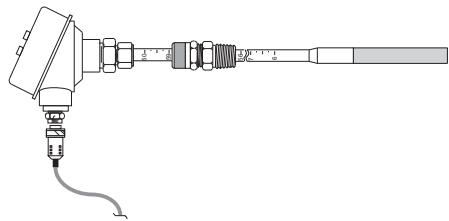

VALVE LIMIT SWITCHES

PWR

IA

SV

ENERG ← →

DE-ENERG →

SS BRAIDED AIR HOSE

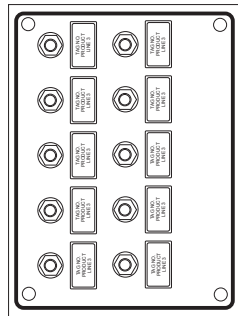

VALVE SELECT PATCH PANEL

USER SUPPLIED →

PRODUCT 1

PRODUCT 2

PRODUCT 3



FC

TO RAIL CAR



FC

TO RAIL CAR

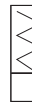

FC

TO RAIL CAR

TYPICAL FOR UP TO 10 PRODUCT VALVES PER CONTROLLER



INDUSTRIAL FLUID CONTROLS
CINCINNATI, OHIO 45246
(513) 874-8499



JOSEPH SHEFFSKY, P.E. 04/12/12

PROPOSED VALVE SELECT PATCH PANEL

DRAWING NO. SK-041212-3

REV 060113

Batchguard™

Model A-300 SP-0612

RESET
(OPEN)



TRIP
(CLOSE)

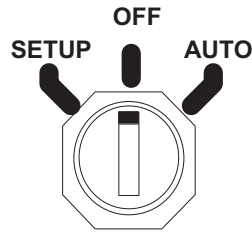
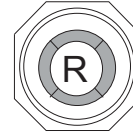

VERTICAL
OK



HI-HI
LEVEL
(PUSH TO ACKN.)

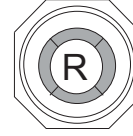

PRODUCT VALVES
RED - CLOSED
GREEN FLASH - OPEN

TAG NO. PRODUCT LINE 3	TAG NO. PRODUCT LINE 3	TAG NO. PRODUCT LINE 3	TAG NO. PRODUCT LINE 3	TAG NO. PRODUCT LINE 3
TAG NO. PRODUCT LINE 3	TAG NO. PRODUCT LINE 3	TAG NO. PRODUCT LINE 3	TAG NO. PRODUCT LINE 3	TAG NO. PRODUCT LINE 3



INDUSTRIAL FLUID CONTROLS CINCINNATI, OHIO 45246
(513) 874-8499



CONTROLLER FRONT ELEVATION
15.5"W x 18"H x 8.75"D

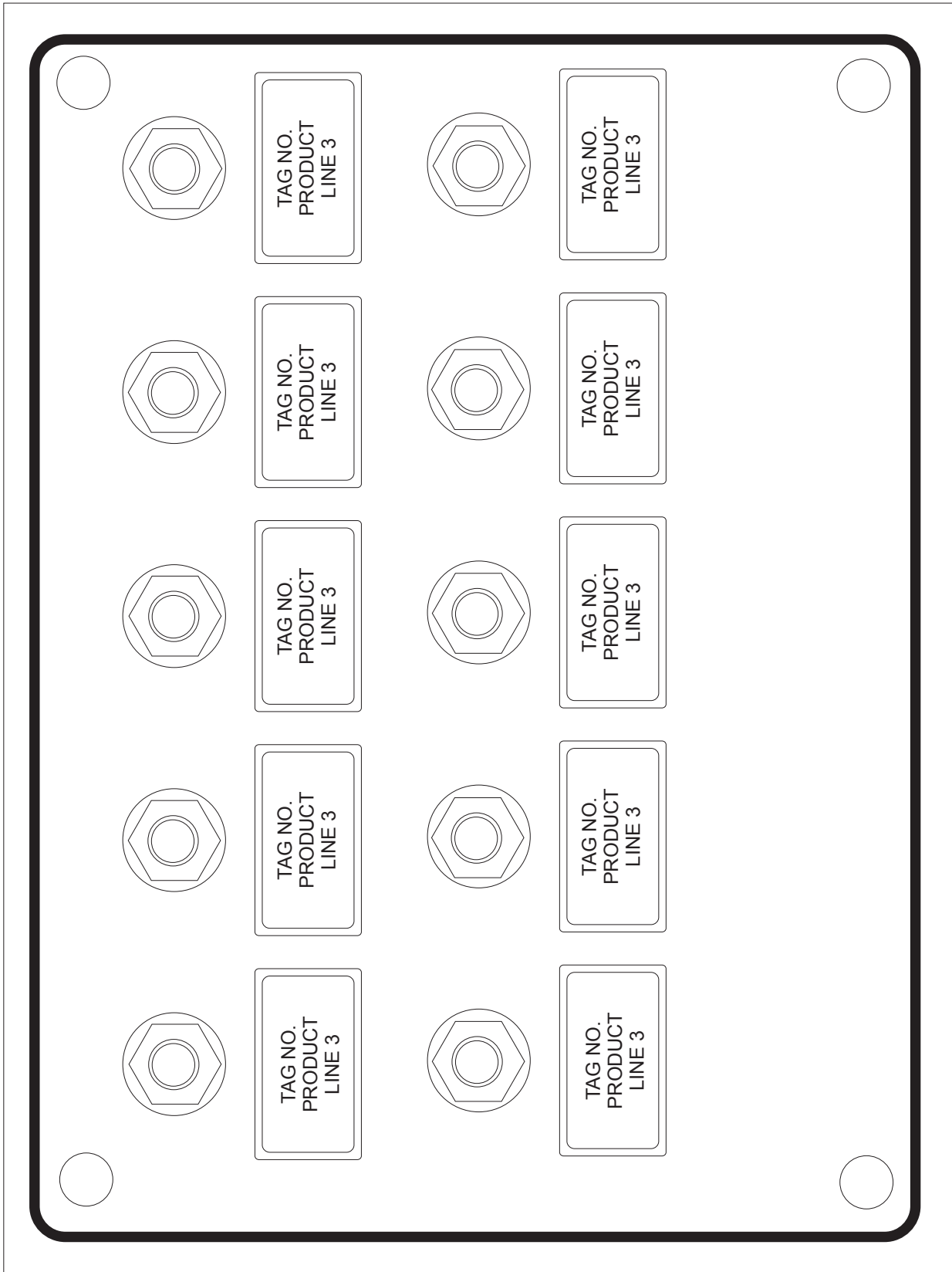

**PATCH PANEL 8" X 12" X 1/4" THK
ANODIZED ALUMINUM FACE WITH
REMOVABLE NAME TAGS**

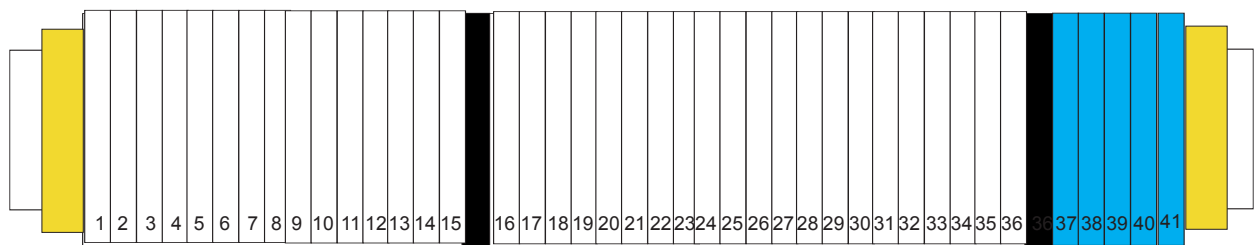
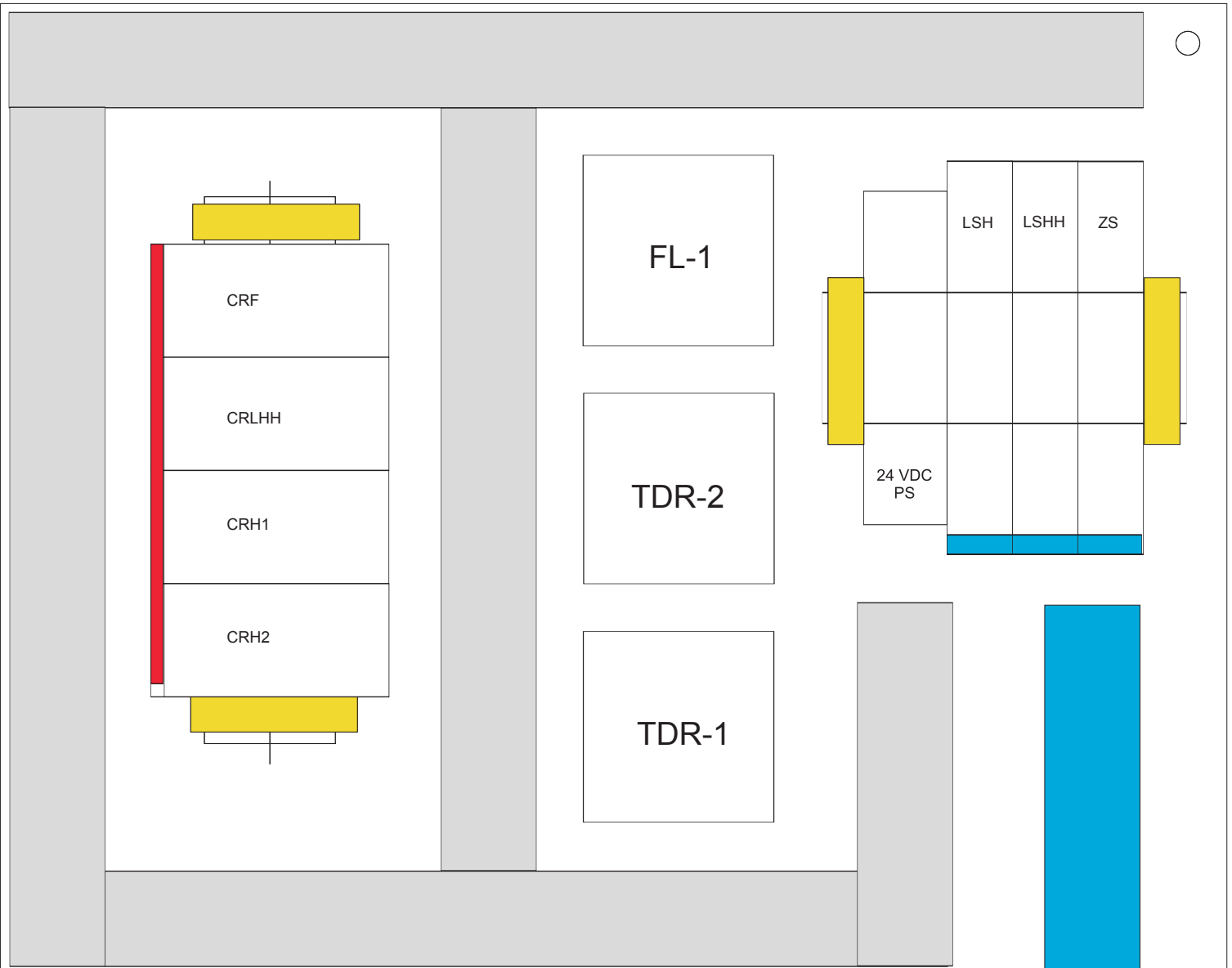

15 - MAIN PANEL

21 VALVE POS LIGHTS

5 - IS

CONTROL PANEL LAYOUT

Rev 02/19/13
 Changed order
 LSH LSHH ZS

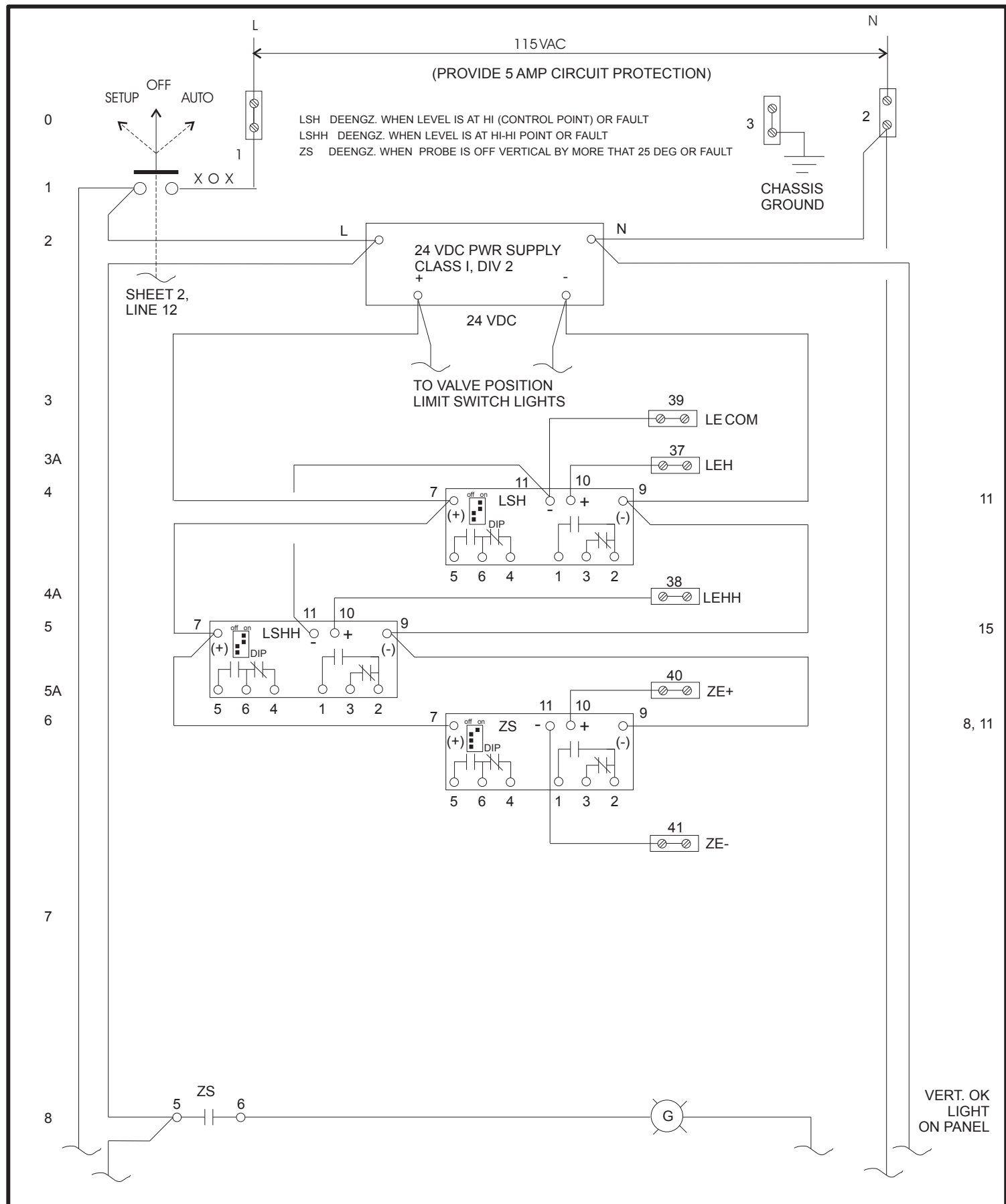

INDUSTRIAL FLUID CONTROLS
 CINCINNATI, OHIO 45246
 (513) 874-8499



JOSEPH SHEFSKY, P.E.

06/15/12

A300-CTR-SP0612 CONTROLLER
 SCHEMATIC DIAGRAM

SH 1 OF 4

DRAWING NO.

20120615-1

Rev 032313

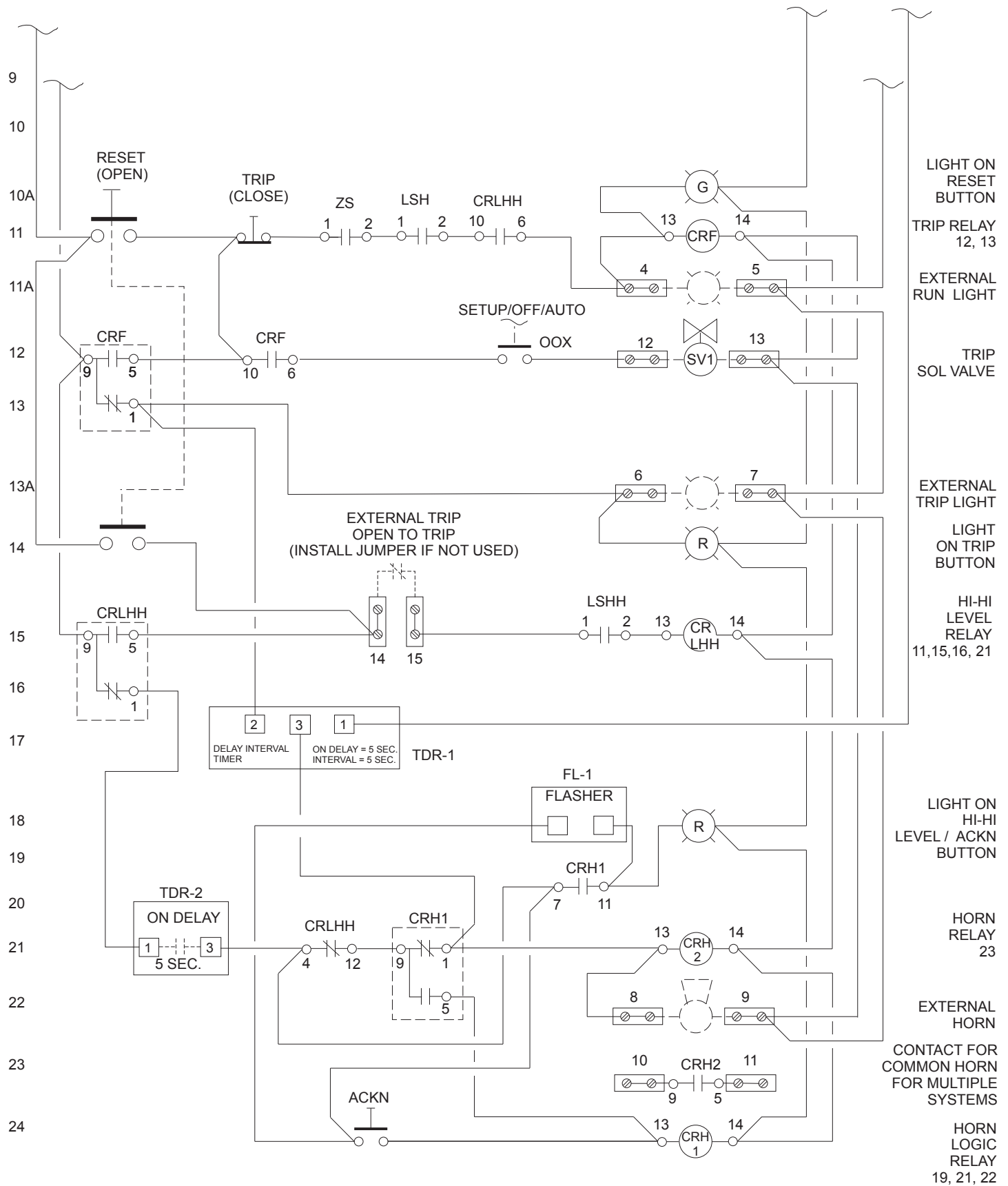

INDUSTRIAL FLUID CONTROLS
CINCINNATI, OHIO 45246
(513) 874-8499



JOSEPH SHEFSKY, P.E.

06/15/12

A300-CTR-SP0612 CONTROLLER
SCHEMATIC DIAGRAM

SH 2 OF 4

DRAWING NO.

20120615-2

REV 032313

TB-1

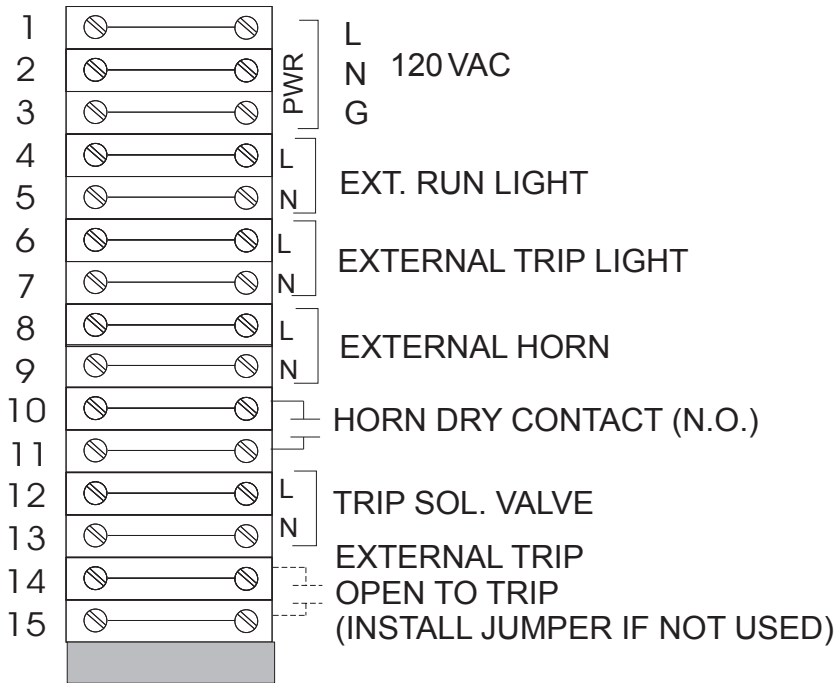

TB-2

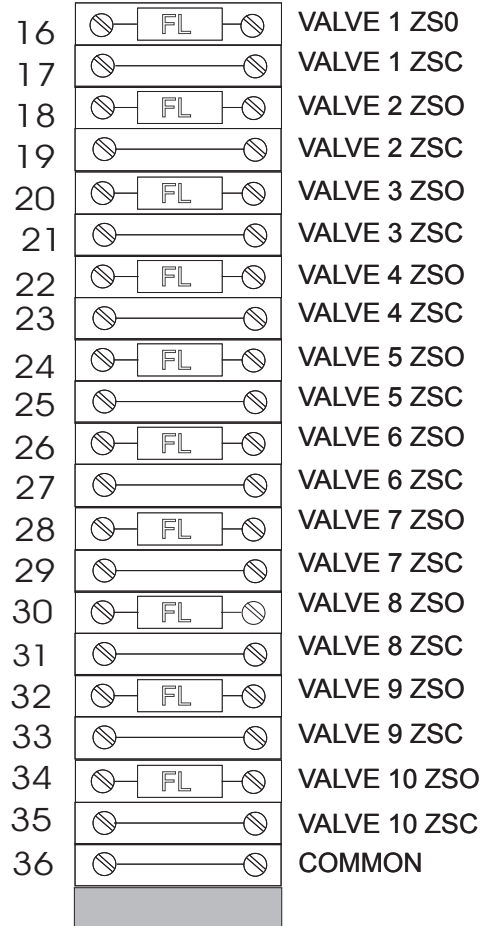

NOTE: FLASHER MODULE
PREWIRED INTO TERMINAL

TB-3

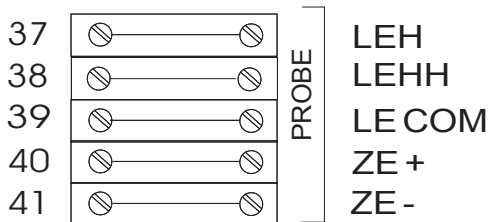

INDUSTRIAL FLUID CONTROLS
CINCINNATI, OHIO 45246
(513) 874-8499



JOSEPH SHEFSKY, P.E.

09/18/12

A300-CTR-SP0612 CONTROLLER TERMINAL
STRIP LAYOUT SH 3 OF 4

DRAWING NO.

20120615-3

Rev 010313

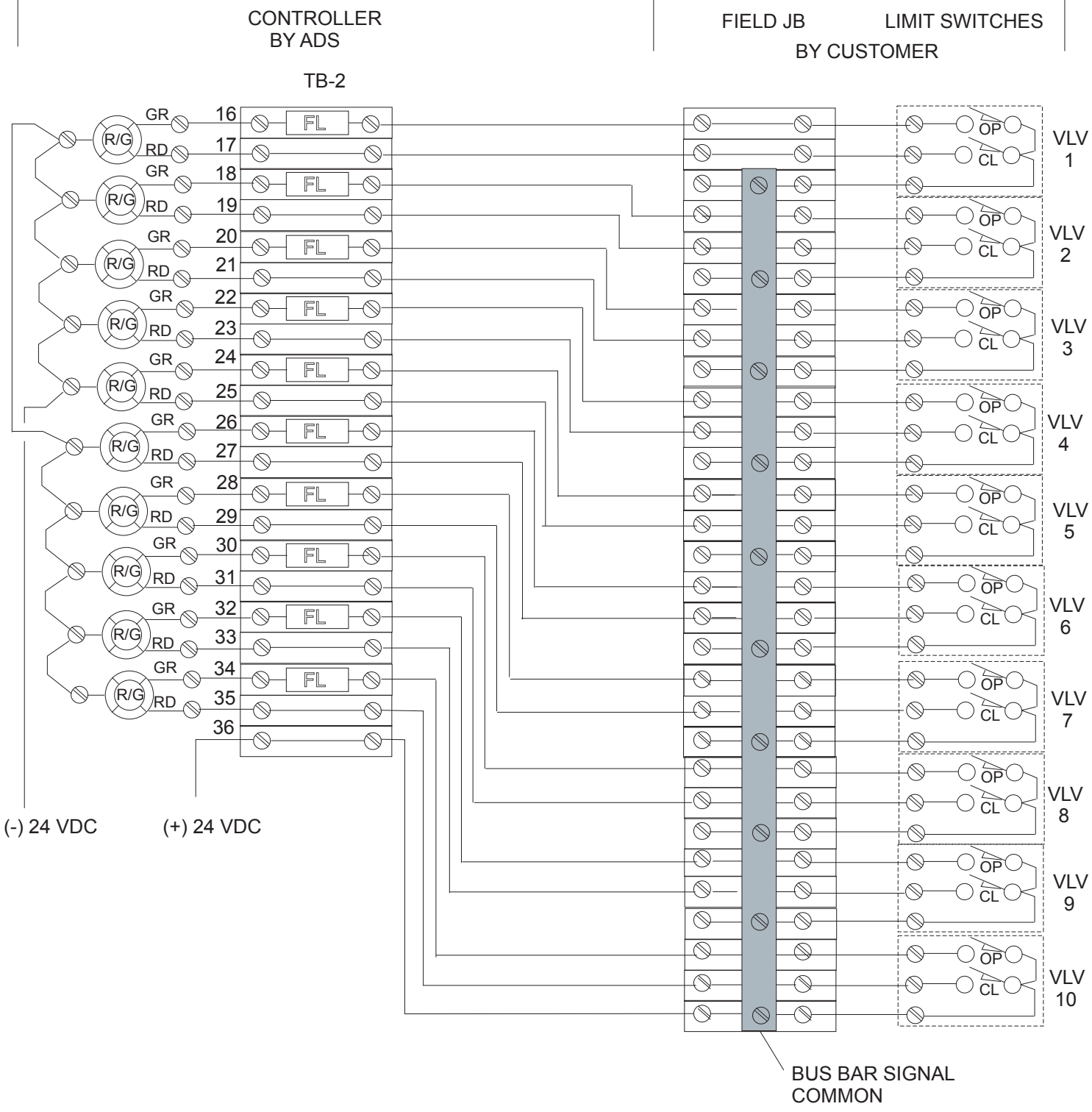

INDUSTRIAL FLUID CONTROLS
 CINCINNATI, OHIO 45246
 (513) 874-8499



JOSEPH SHEFSKY, P.E.

06/15/12

A300-SP0612 SYSTEM VALVE POSITION
 INDICATOR WIRING DIAGRAM

SH 4 OF 4

DRAWING NO.

20120615-4

Rev 032313

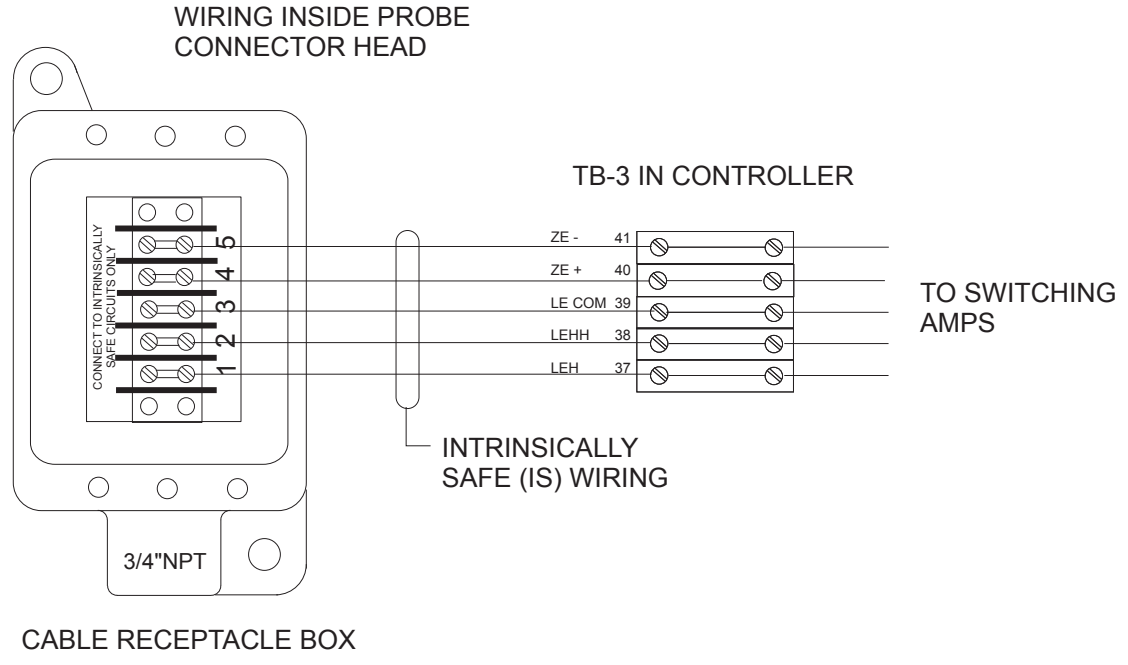
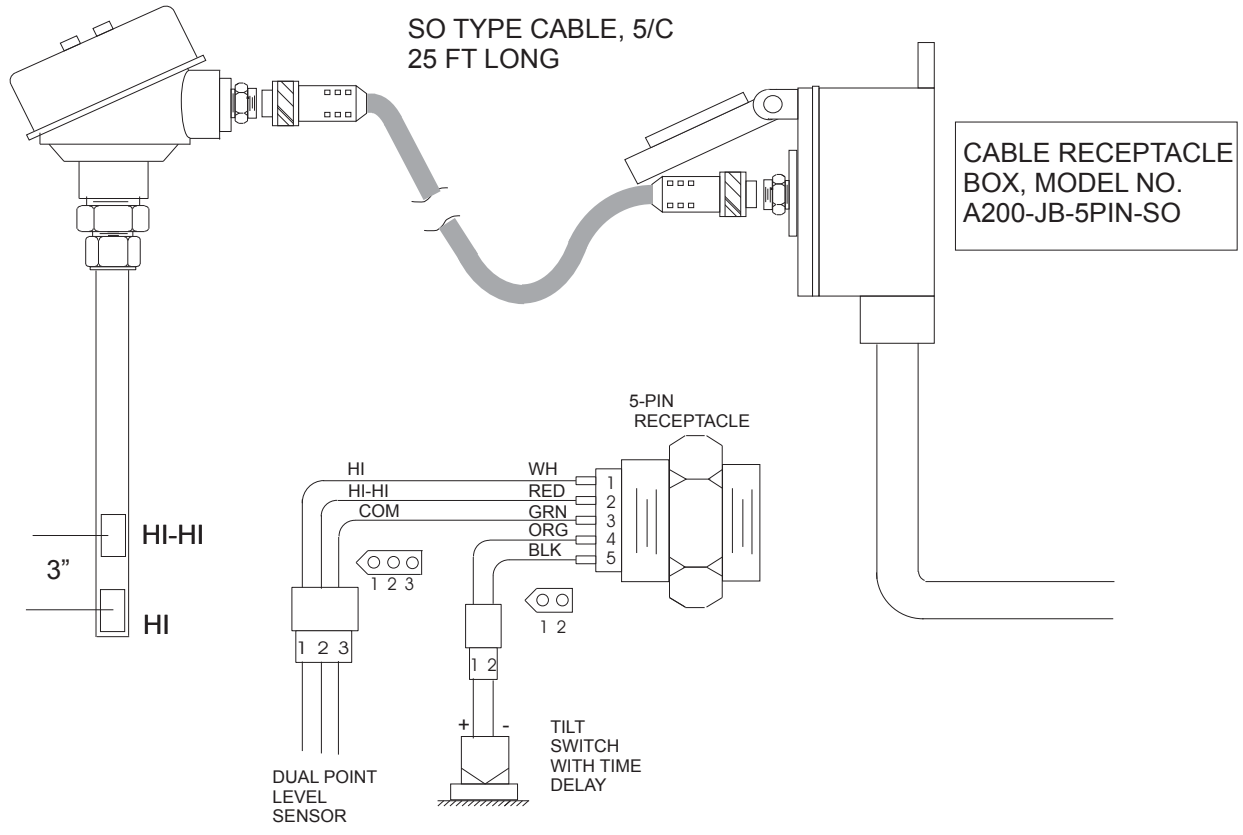

INDUSTRIAL FLUID CONTROLS
CINCINNATI, OHIO 45246
(513) 874-8499



JOSEPH SHEFSKY, P.E.

01/08/13

SENSOR WIRING DIAGRAM A300-SP0612 DUAL LEVEL PLUS TILT SWITCH

DRAWING NO.

20130108-1

Rev 060113

- INTRINSICALLY SAFE DESIGN, CLASS I, DIV 1
- RUGGED, RELIABLE TIP SENSITIVE DUAL INDEPENDENT CAPACITANCE SENSOR.
- OPTIONAL TILT SWITCH INTERLOCK WITH ELECTRONIC TIME DELAY
- MAX TEMPERATURE, 250 DEG F MAX
- WETTED MATERIAL 316SS AND TEFLON™
- GRADUATED ROD 316SS, FULL HARD, LASER ENGRAVED.
- VARIABLE INSERTION LENGTH
- WORKS WITH ANY LIQUID WITH A DIELECTRIC CONSTANT OF 1.8 OR GREATER, CONDUCTIVE AND NON-CONDUCTIVE
- NO CALIBRATION REQUIRED.
- MAX PRESSURE 50 P
- LOW CURRENT DRAW, < 1 MA AT 5 VDC.
- STANDARD PROBE LENGTHS UP TO 5 FT

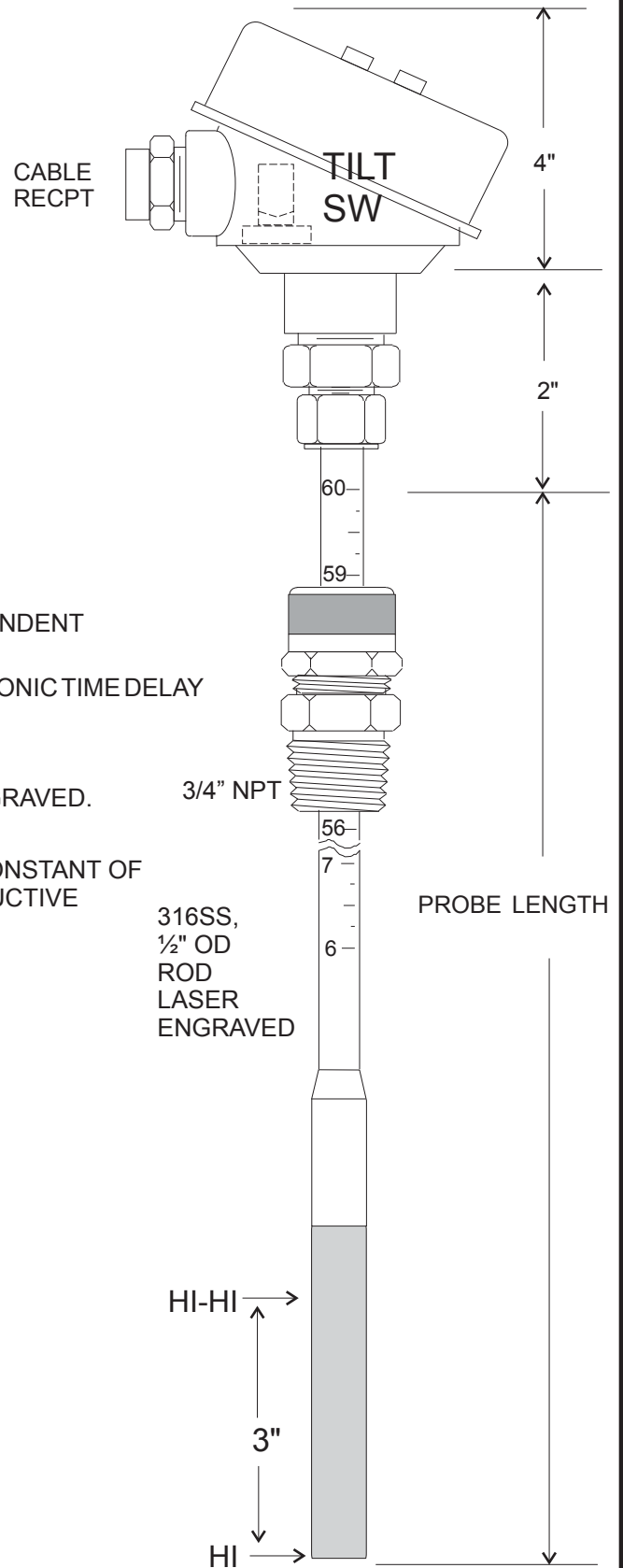

INDUSTRIAL FLUID CONTROLS
CINCINNATI, OHIO 45246
(513) 874-8499



JOSEPH SHEFSKY, P.E.

04/12/12

CAPACITANCE LIQUID LEVEL PROBE, DUAL INDEPENDENT SENSORS WITH OPTIONAL TILT SWITCH

DRAWING NO.

SK-041212-2

Rev 060113

DUAL-POINT *Phase Shift*[™] LIQUID LEVEL PROBE

- DIRECTLY INTERCHANGEABLE WITH DUAL POINT ULTRASONIC PROBE
- TOTALLY INDEPENDENT HI AND HI-HI SENSORS
- WORKS FOR ALL FLUIDS WITH DIELECTRIC CONSTANT 0 1.8 OR GREATER
- NO CALIBRATION REQUIRED, NOT AFFECTED BY TANK GEOMETRY
- HEAVY DUTY PRESSURE TIGHT SLIDING FITTING WITH LOCKING COLLET
- FULL HARD 316 SS SHAFT WITH LASER ENGRAVED SCALE
- OPTIONAL PRESSURE SENSOR FOR ADDITIONAL LAYER OF PROTECTION

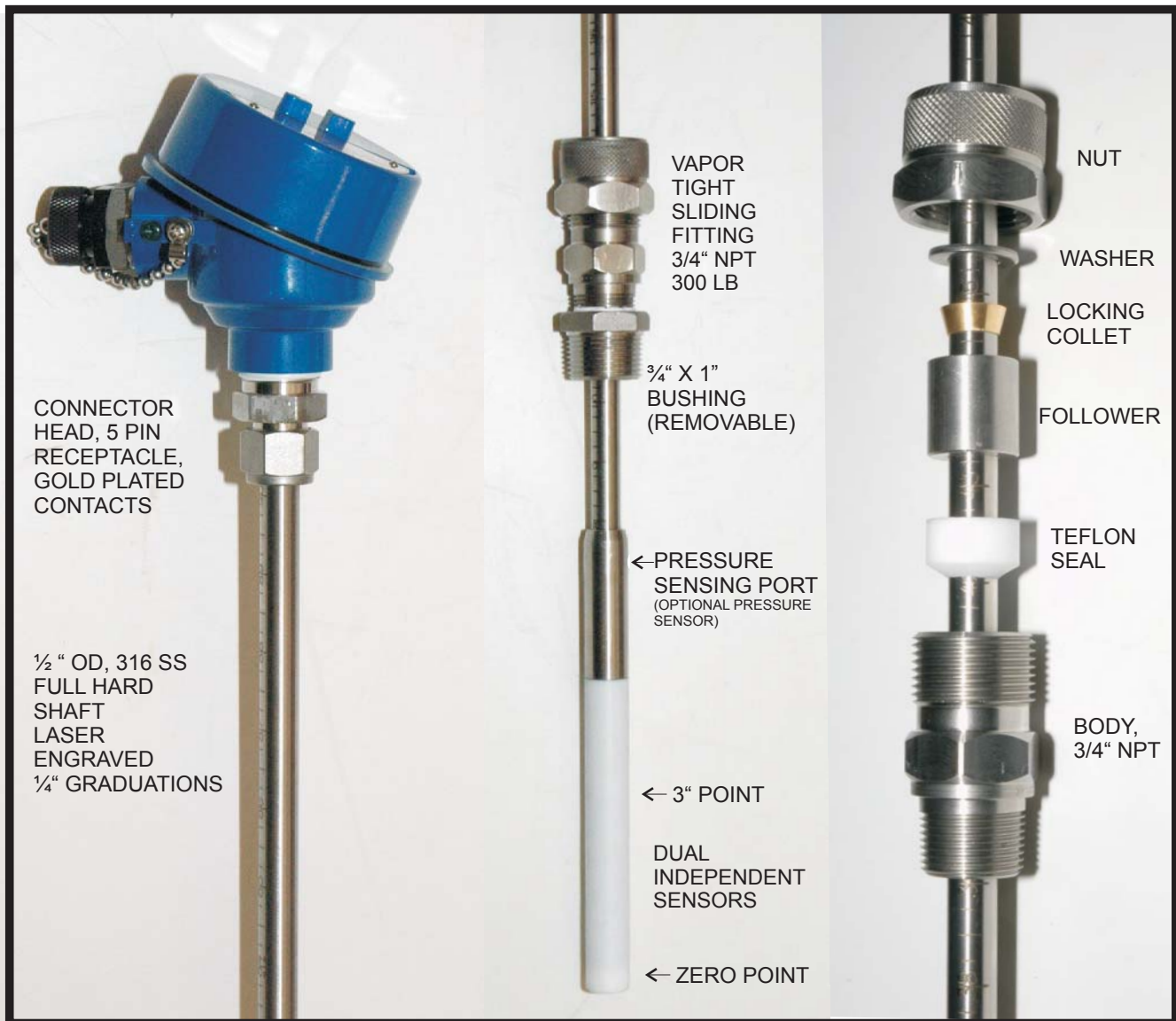

CONNECTOR HEAD, 5 PIN RECEPTACLE, GOLD PLATED CONTACTS

1/2" OD, 316 SS FULL HARD SHAFT LASER ENGRAVED 1/4" GRADUATIONS

VAPOR TIGHT SLIDING FITTING 3/4" NPT 300 LB

3/4" X 1" BUSHING (REMOVABLE)

← PRESSURE SENSING PORT (OPTIONAL PRESSURE SENSOR)

← 3" POINT

DUAL INDEPENDENT SENSORS

← ZERO POINT

NUT

WASHER

LOCKING COLLET

FOLLOWER

TEFLON SEAL

BODY, 3/4" NPT



INDUSTRIAL FLUID CONTROLS CINCINNATI, OHIO 45246
(513) 874-8499





OPTIONAL

STAINLESS STEEL ARMORED CABLE
 STANDARD LENGTHS 15, 20, 25 FT.
 LENGTHS UP TO 100 FT AVAILABLE.



SO STYLE RUBBER JACKET CABLE



CABLE CONNECTORS

INDUSTRY STANDARD SO TYPE CABLE

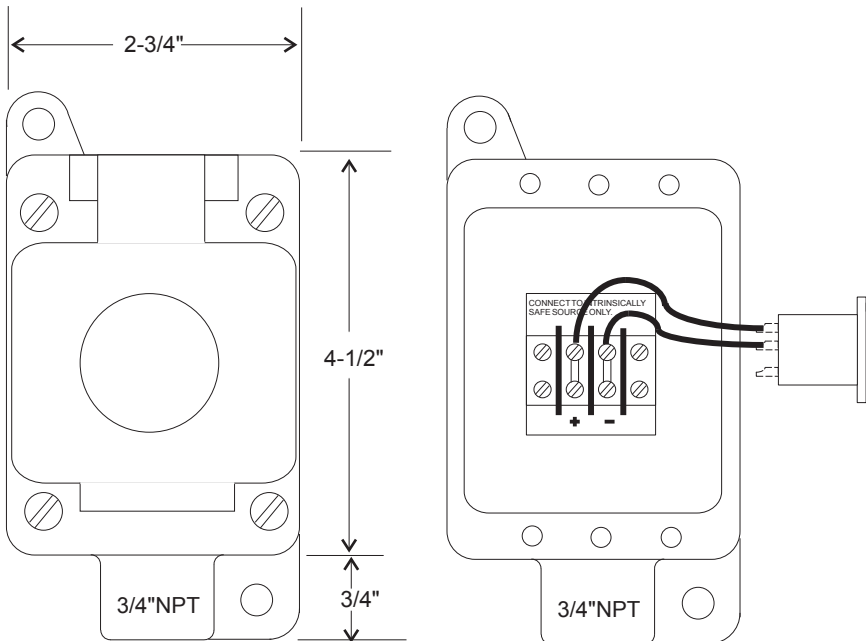

CABLE JUNCTION BOX FOR MODELS A-100 AND A-200

CONTROLLER MODEL A300-CTR-SP0612

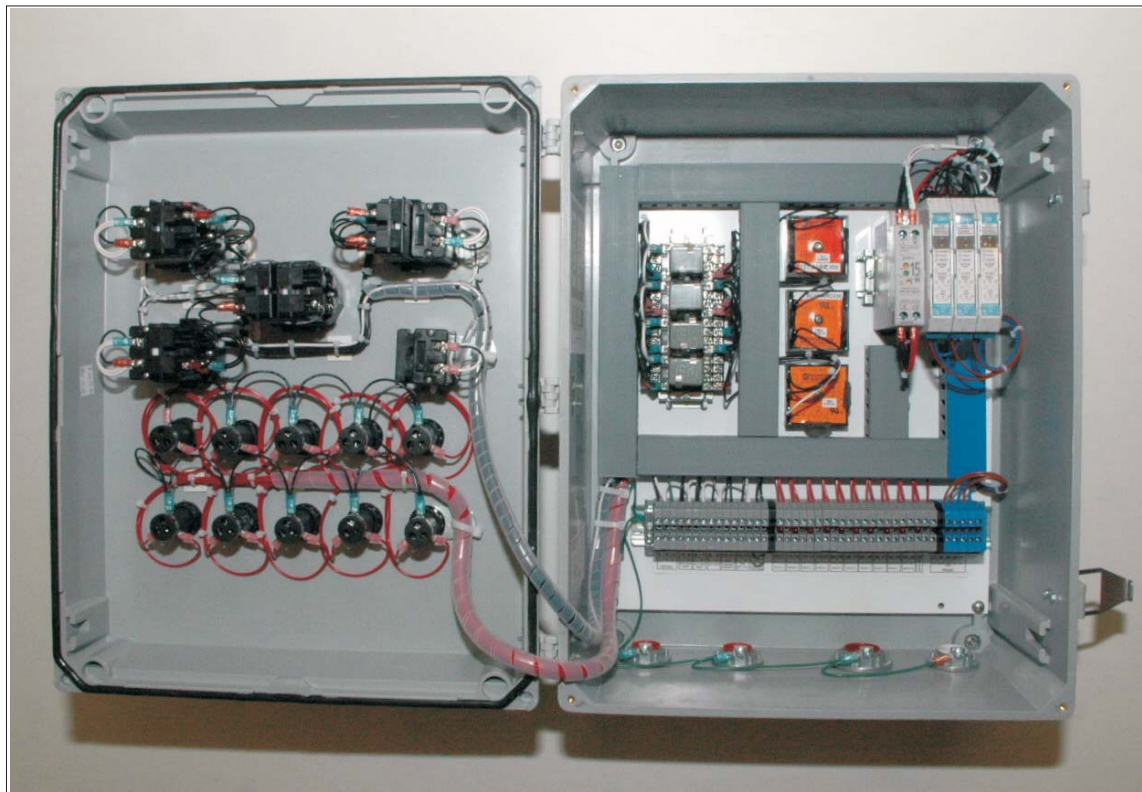



PNEUMATIC PRODUCT SELECT PANEL

INDUSTRIAL FLUID CONTROLS

CINCINNATI, OHIO 45246 (513) 874-8499

dixonvalve.com

PROBES



Manufacturers of liquid level controls for overflow prevention.

- **Liquid terminal automation**
- **Field storage**

- INTRINSICALLY SAFE DESIGN, CLASS I, DIV 1
- RUGGED, RELIABLE TIP SENSITIVE CAPACITANCE SENSOR.
- MAX TEMPERATURE, 212 DEG F MAX
- WETTED MATERIAL 316SS AND TEFLON
- GRADUATED ROD, LASER ENGRAVED.
- VARIABLE INSERTION LENGTH
- WORKS WITH ANY LIQUID WITH CONSTANT OF 1.8 OR GREATER.
- NO CALIBRATION REQUIRED.
- MAX PRESSURE 50P(300PHIGH PRESS FITTING)
- LOW CURRENT DRAW, 0.50 MA AT 5 VDC.

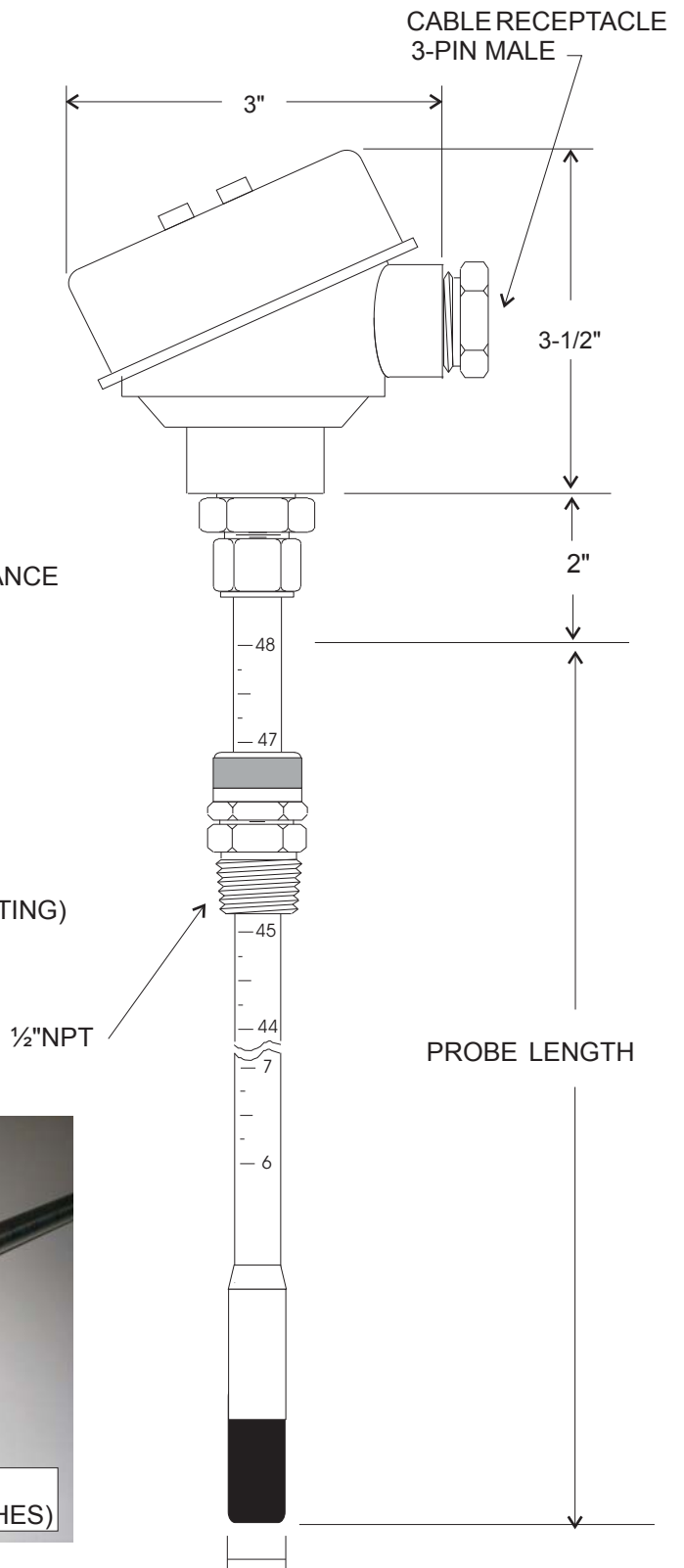
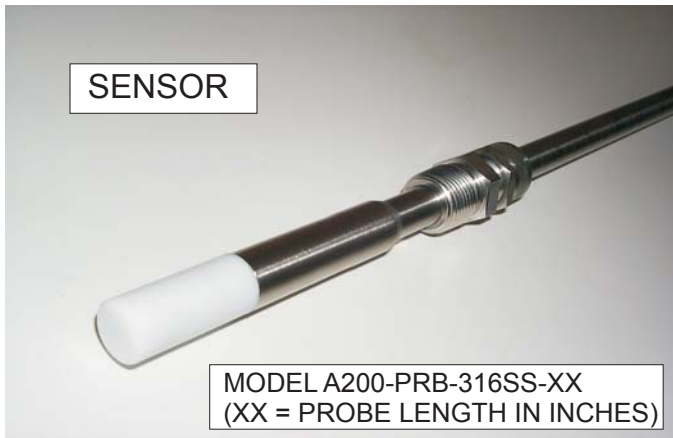

(WILL PASS THRU 1/2" NPT)



INDUSTRIAL FLUID CONTROLS
CINCINNATI, OHIO 45246
(513) 874-8499



JOSEPH SHEFSKY, P.E.

10/15/00

MODEL A-200 LEVEL PROBE, CAPACITANCE SENSOR

DRAWING

2000912-5

REV 04/14

- ELECTRICALLY AND MECHANICALLY INTERCHANGEABLE WITH EXISTING A-200 CAPACITANCE SENSORS-
- INTRINSICALLY SAFE DESIGN, CLASS I, DIV 1 WITH ADS, INC. INTERFACE.
- RUGGED, RELIABLE CONDUCTIVITY SENSOR
- TEMPERATURE, 300 DEG F MAX, HIGH TEMP OPTION 500 DEG F.
- WETTED MATERIAL 316SS AND TEFLON™
- GRADUATED ROD, LASER ENGRAVED.
- VARIABLE INSERTION LENGTH
- WORKS WITH CONDUCTIVE FLUIDS ONLY.
- SENSITIVITY 0.2 - 3.3 MEG OHM ADJUSTABLE. FACTORY SETTING 200 K OHM UNLESS SPECIFIED OTHERWISE.
- MAX PRESSURE 50 P (300 P HIGH PRESS FITTING)
- LOW CURRENT DRAW, 0.50 MA AT 5 VDC.
- INTEGRAL SPLASH SHIELD - SINGLE ELECTRODE DESIGN

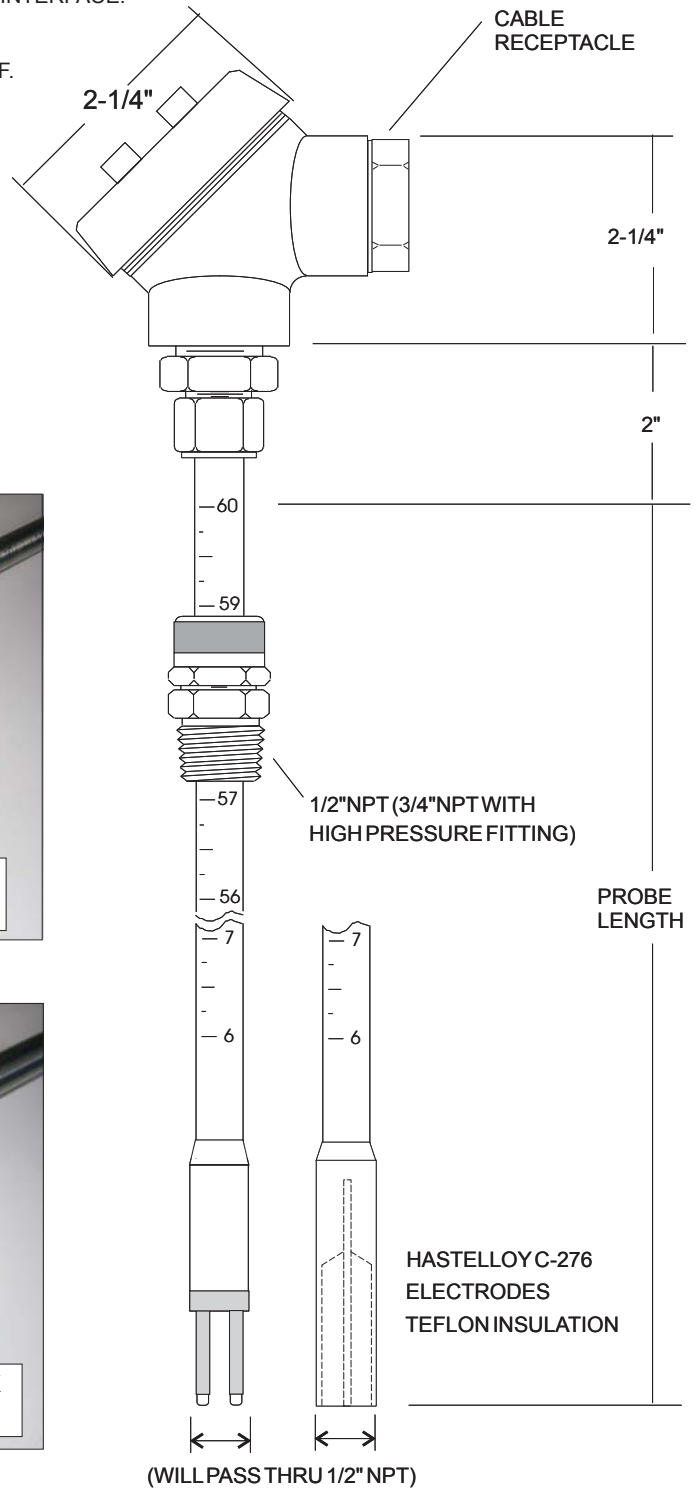

INDUSTRIAL FLUID CONTROLS
CINCINNATI, OHIO 45246
(513) 874-8499

JOSEPH SHEFSKY, P.E.

9/12/00

MODEL A-200 CONDUCTIVITY LEVEL PROBE
SINGLE AND DUAL ELECTRODES



DRAWING

2000912-5

REV 06/11

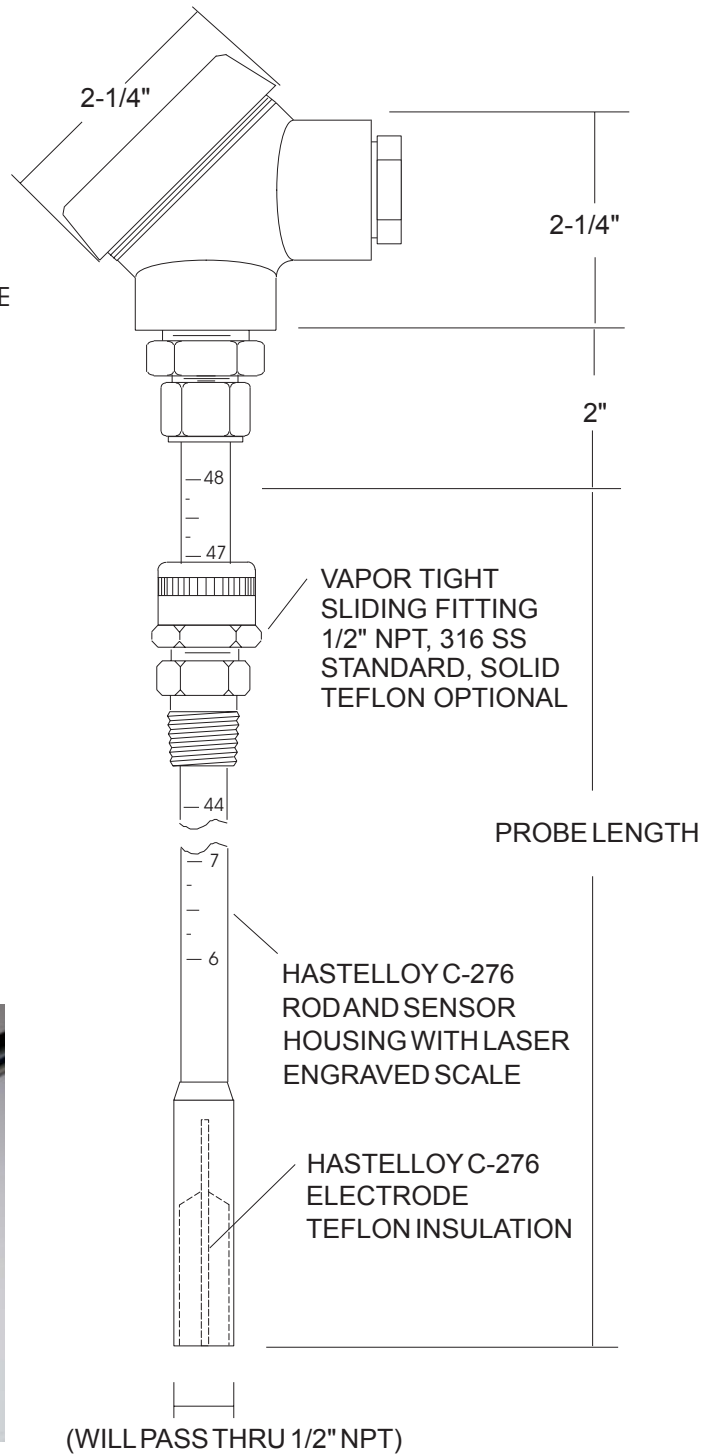
- INTEGRAL SPLASH SHIELD
- ELECTRICALLY AND MECHANICALLY INTERCHANGEABLE WITH EXISTING A-200 CAPACITANCE SENSORS
- INTRINSICALLY SAFE DESIGN, CLASS I, DIV 1
- RUGGED, RELIABLE CONDUCTIVITY SENSOR
- MAX TEMPERATURE, 250 DEG F
- WETTED MATERIAL HASTELLOY C-276 AND TEFLON™
- GRADUATED ROD, LASER ENGRAVED.
- VARIABLE INSERTION LENGTH
- SPECIFICALLY TUNED FOR HYDROCHLORIC ACID
- SENSITIVITY 5K OHMS (ADJUSTABLE 2K-20K OHMS)
- MAX PRESSURE 50 P
- LOW CURRENT DRAW, 0.50 MA AT 5 VDC.



 <p>INDUSTRIAL FLUID CONTROLS CINCINNATI, OHIO 45246 (513) 874-8499</p>		JOSEPH SHEFSKY, P.E.	2/26/02
		MODEL A-200 CONDUCTIVITY PROBE WITH INTEGRAL SPLASH SHIELD FOR TOP LOADING HYDROCHLORIC ACID	
		DRAWING NUMBER	20020226-3

- ELECTRICALLY AND MECHANICALLY INTERCHANGABLE WITH EXISTING A-200 CAPACITANCE SENSORS
- NAMUR OUTPUT
- INTRINSICALLY SAFE DESIGN, CLASS I, DIV 1
- RUGGED, RELIABLE CONDUCTIVITY SENSOR
- 300 DEG F MAX
- WETTED MATERIAL HASTELLOY C-276 AND TEFLON™ (SLIDING FITTING 316 SS)
- GRADUATED ROD, LASER ENGRAVED.
- VARIABLE INSERTION LENGTH
- WORKS WITH ANY CONDUCTIVE LIQUID
- SENSITIVITY 0-500,000 OHM ADJUSTABLE (FACTORY SET AT 20,000 OHM)
- MAX PRESSURE 50 P (300 P HIGH PRESS FITTING)
- LOW CURRENT DRAW, 0.50 MA AT 5 VDC.
- AVAILABLE LENGTHS, 2, 3, 4, AND 5 FEET.

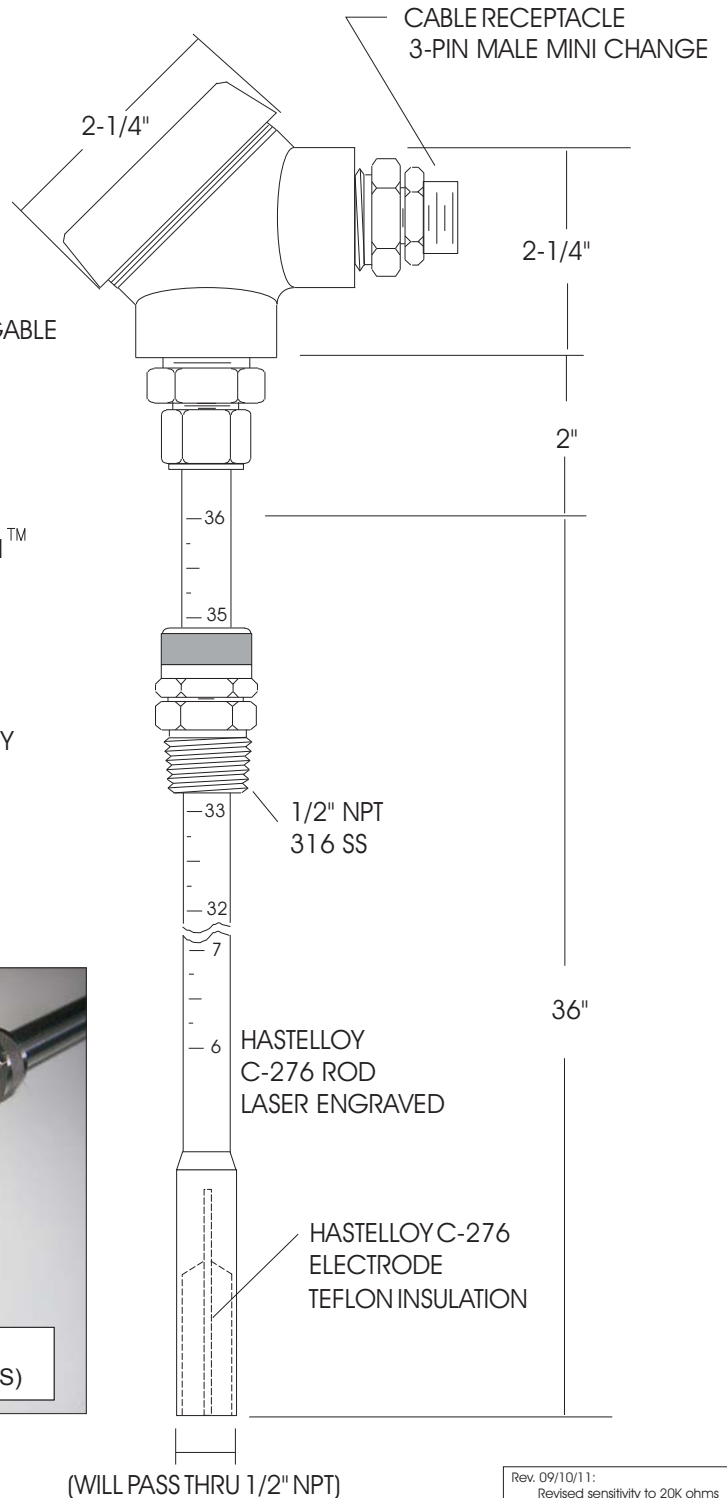

INDUSTRIAL FLUID CONTROLS
CINCINNATI, OHIO 45246
(513) 874-8499



JOSEPH SHEFSKY, P.E.

9/12/09

MODEL A-200 CONDUCTIVITY PROBE FOR HCL SERVICE

DRAWING NO.

2009912-1

Rev 09/10/11

- INTRINSICALLY SAFE DESIGN, CLASS I, DIV 1
- RUGGED, RELIABLE TIP SENSITIVE CAPACITANCE LEVEL SENSOR WITH ALL 316 SS PRESSURE TRANSDUCER.
- DUAL SETPOINT PRESSURE SENSOR. STANDARD CALIBRATION RANGE 0 - 50 PSIA, HIGHER RANGES AVAILABLE.
- MAX TEMPERATURE, 250 DEG F MAX
- WETTED MATERIAL 316SS AND TEFLON™
- GRADUATED ROD, LASER ENGRAVED UP TO 8 FT LONG.
- VARIABLE INSERTION LENGTH
- WORKS WITH ANY LIQUID WITH A DIELECTRIC CONSTANT OF 1.8 OR GREATER.
- OPTIONAL SLIDING FITTING WITH ELECTRICAL GROUND AND MECHANICAL LOCK UP TO 300 PSI RATING.
- OPTIONAL TILT AND GROUND VERIFICATION INTERLOCK

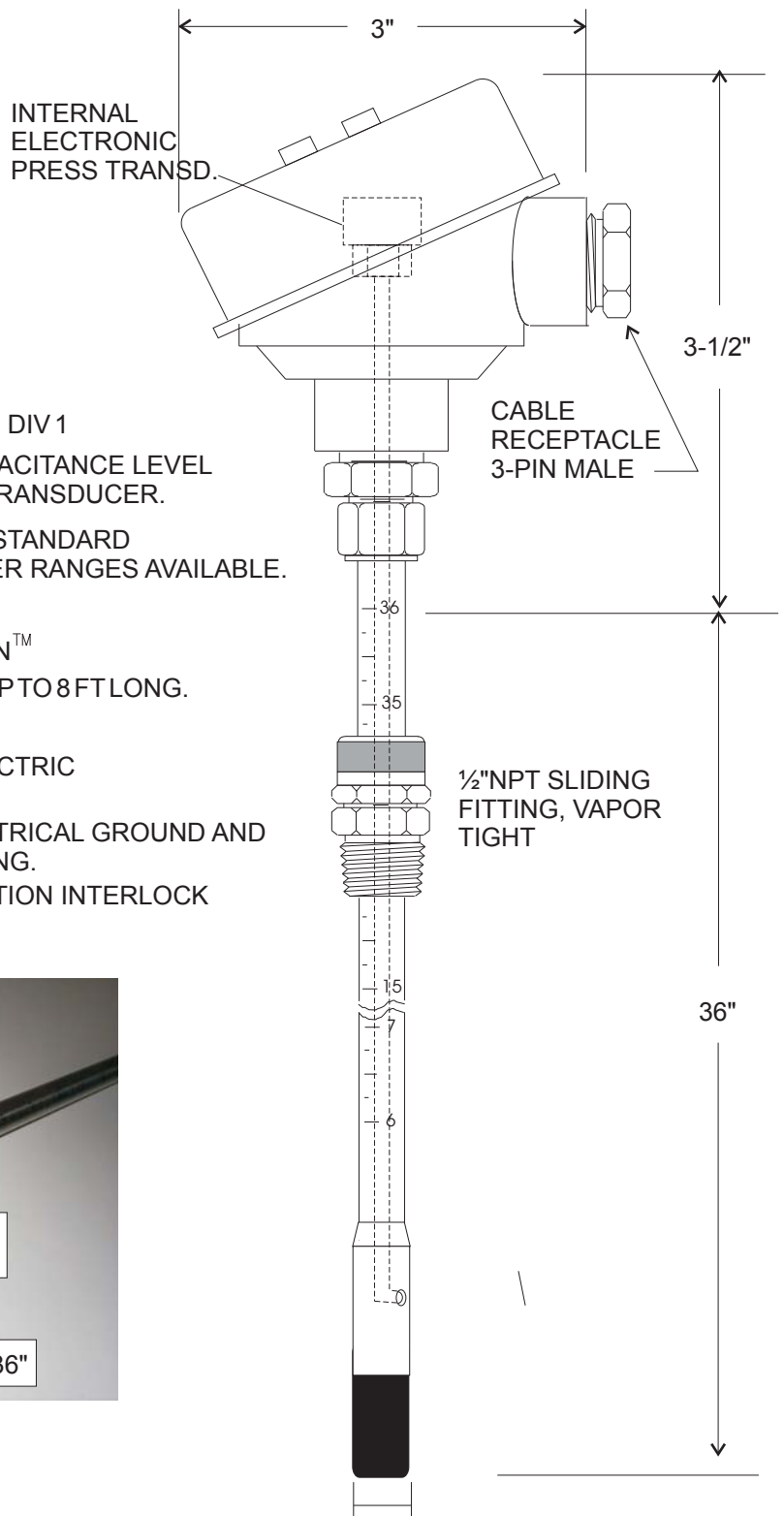
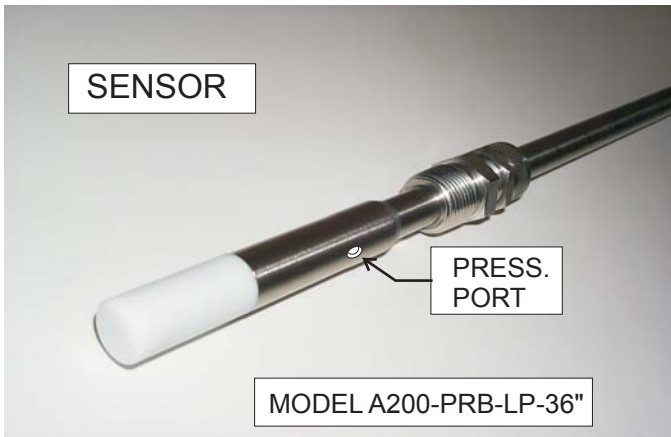

(WILL PASS THRU 1/2" NPT)



INDUSTRIAL FLUID CONTROLS
CINCINNATI, OHIO 45246
(513) 874-8499



JOSEPH SHEFSKY, P.E.

10/15/13

MODEL A-200 LEVEL/PRESSURE PROBE, CAPACITANCE SENSOR, NEW INTERNAL PRESSURE TRANSDUCER

DRAWING

SK-101513-2

— CAUTION —

THE POSITION OF THE UPPER AND LOWER FLOAT STOP COLLARS IS CRITICAL TO THE PROPER OPERATION OF THE PROBE. IF THE FLOAT NEED TO BE TEMPORARILY REMOVED BE SURE TO REPLACE THE STOP COLLARS AT THE ORIGINAL LOCATIONS. THE PROPER LOCATIONS ARE ETCHED ON THE ROD.

- INTRINSICALLY SAFE DESIGN, CLASS I, DIV 1
- RUGGED, RELIABLE MAGNETIC FLOAT SENSOR WITH HERMETICALLY SEALED REED SWITCH
- MAX TEMPERATURE, 400 DEG F
- WETTED MATERIAL 316SS AND TEFLON™
- VARIABLE INSERTION LENGTH
- WORKS WITH ANY LIQUID WITH SPECIFIC GRAVITY GREATER THAN 0.65
- NO CALIBRATION REQUIRED.
- MAX PRESSURE 50 P (300 P HIGH PRESS FITTING)
- LOW CURRENT DRAW, 0.50 MA AT 5 VDC.

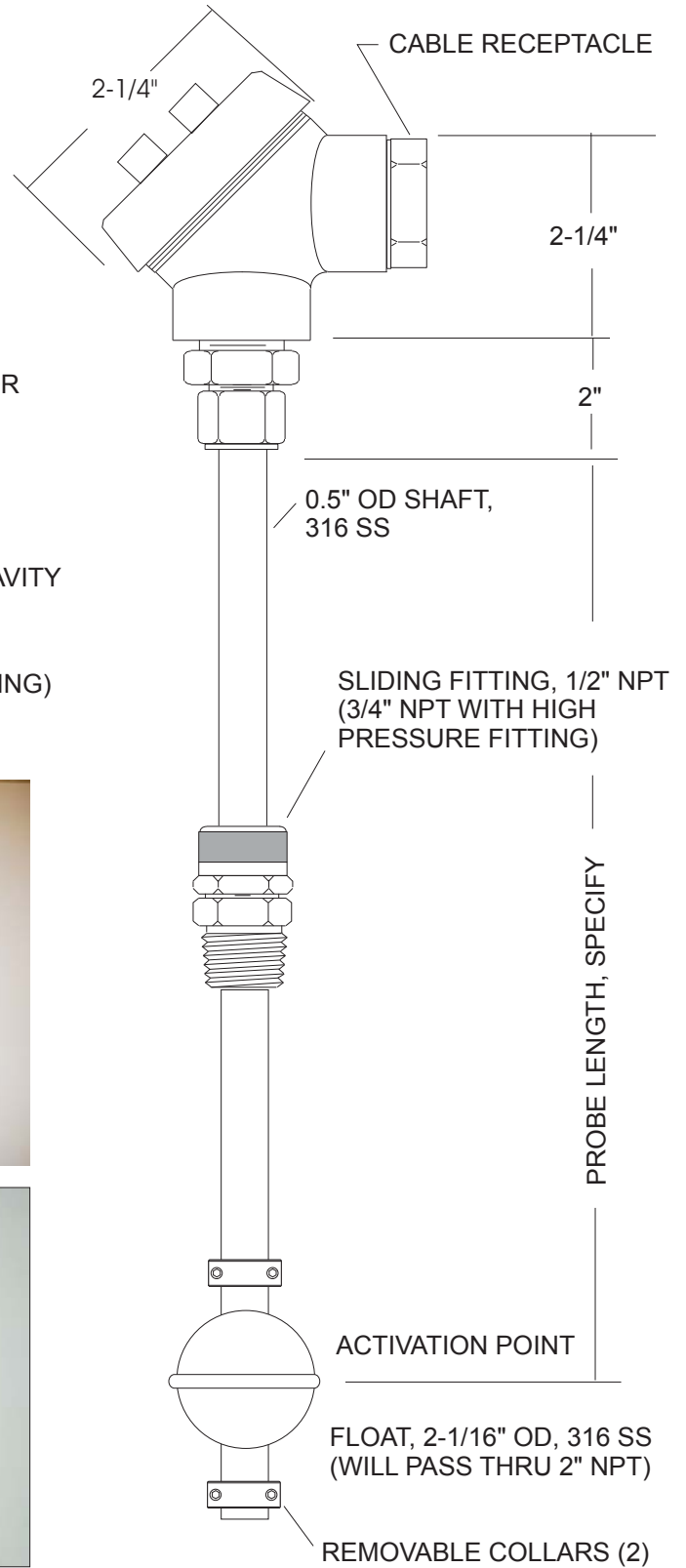
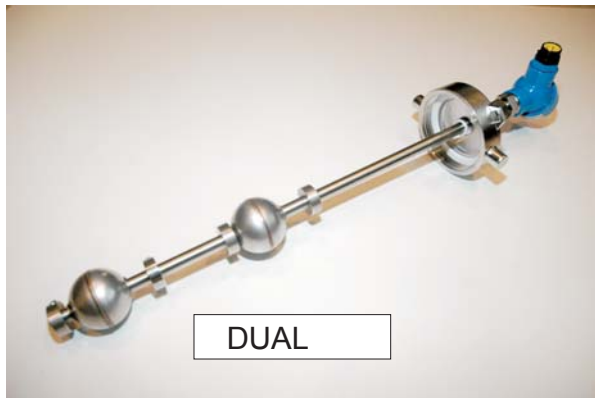

INDUSTRIAL FLUID CONTROLS
 CINCINNATI, OHIO 45246
 (513) 874-8499



JOSEPH SHEFSKY, P.E.

4/11/03

**FLOAT TYPE PROBE FOR SERIES A-200 SYSTEMS
 INTRINSICALLY SAFE**

DRAWING NO

20030411-1

REV. 07/17/07

ULTRASONIC LEVEL PLUS PRESSURE PROBE

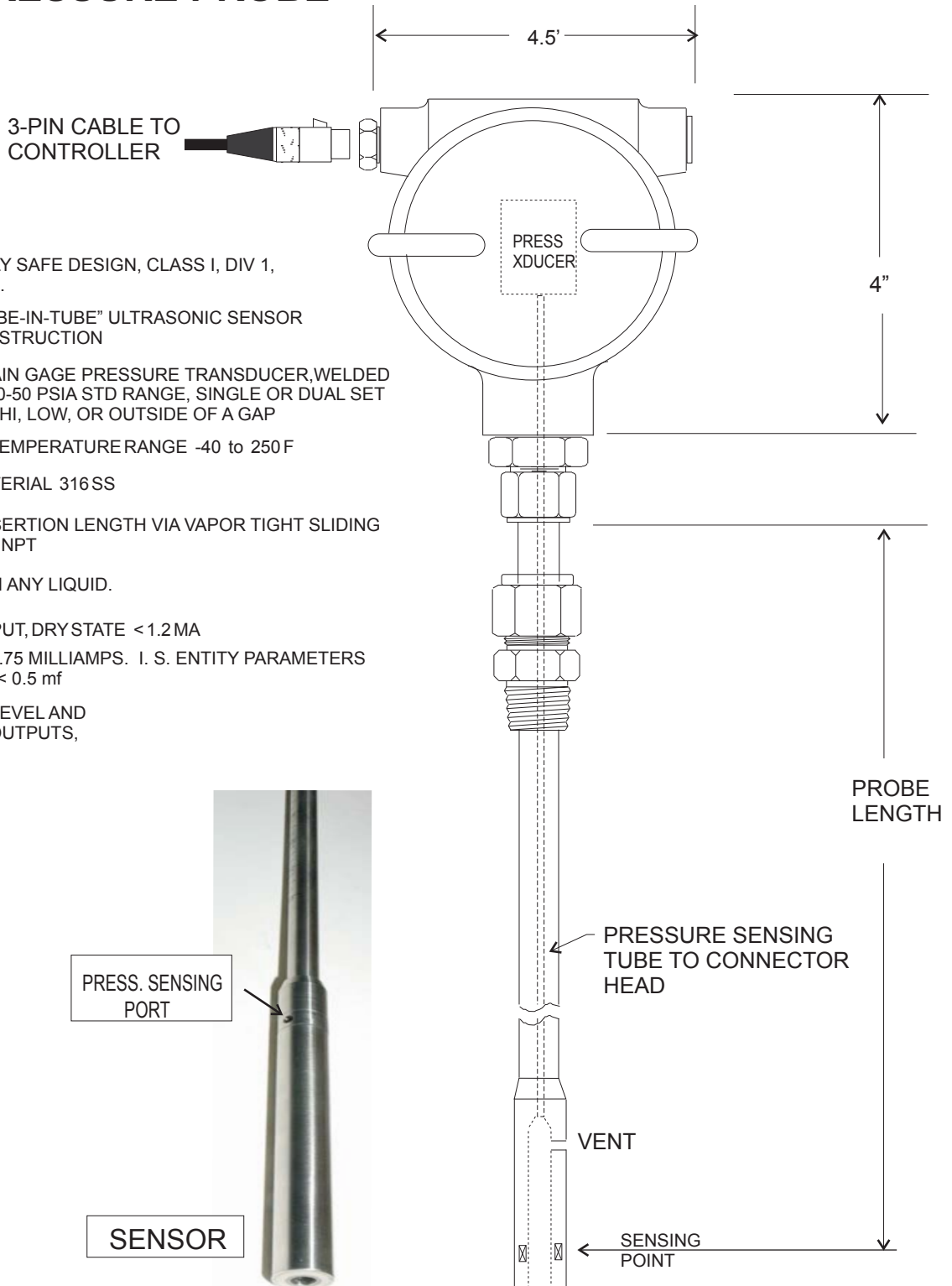

- INTRINSICALLY SAFE DESIGN, CLASS I, DIV 1, GR. A, B, C, D.
- RUGGED, "TUBE-IN-TUBE" ULTRASONIC SENSOR WELDED CONSTRUCTION
- SILICON STRAIN GAGE PRESSURE TRANSDUCER, WELDED DIAPHRAGM, 0-50 PSIA STD RANGE, SINGLE OR DUAL SET POINTS, TRIP HI, LOW, OR OUTSIDE OF A GAP
- OPERATING TEMPERATURE RANGE -40 to 250 F
- WETTED MATERIAL 316SS
- VARIABLE INSERTION LENGTH VIA VAPOR TIGHT SLIDING FITTING, 1/2" MNPT
- WORKS WITH ANY LIQUID.
- NAMUR OUTPUT, DRY STATE < 1.2 MA
WET STATE 2.75 MILLIAMPS. I. S. ENTITY PARAMETERS
L < 0.1 mh, C < 0.5 mf
- INDIVIDUAL LEVEL AND PRESSURE OUTPUTS,



INDUSTRIAL FLUID CONTROLS
CINCINNATI, OHIO 45246
(513) 874-8499

JOSEPH SHEFSKY, P.E.

05/03/16

MODEL A-200 LEVEL/PRESSURE PROBE,
CAPACITANCE LEVEL SENSOR, ELECTRONIC PRESS.

DRAWING

050316-2

DUAL-POINT *Phase Shift*TM LIQUID LEVEL PROBE

- DIRECTLY INTERCHANGEABLE WITH DUAL POINT ULTRASONIC PROBE
- TOTALLY INDEPENDENT HI AND HI-HI SENSORS
- WORKS FOR ALL FLUIDS WITH DIELECTRIC CONSTANT 0 1.7 OR GREATER
- NO CALIBRATION REQUIRED, NOT AFFECTED BY TANK GEOMETRY
- HEAVY DUTY PRESSURE TIGHT SLIDING FITTING WITH LOCKING COLLET
- FULL HARD 316 SS SHAFT WITH LASER ENGRAVED SCALE
- OPTIONAL PRESSURE SENSOR, TILT SWITCH, AND GROUND VERIFICATION INTERLOCK FOR ADDITIONAL LAYERS OF PROTECTION

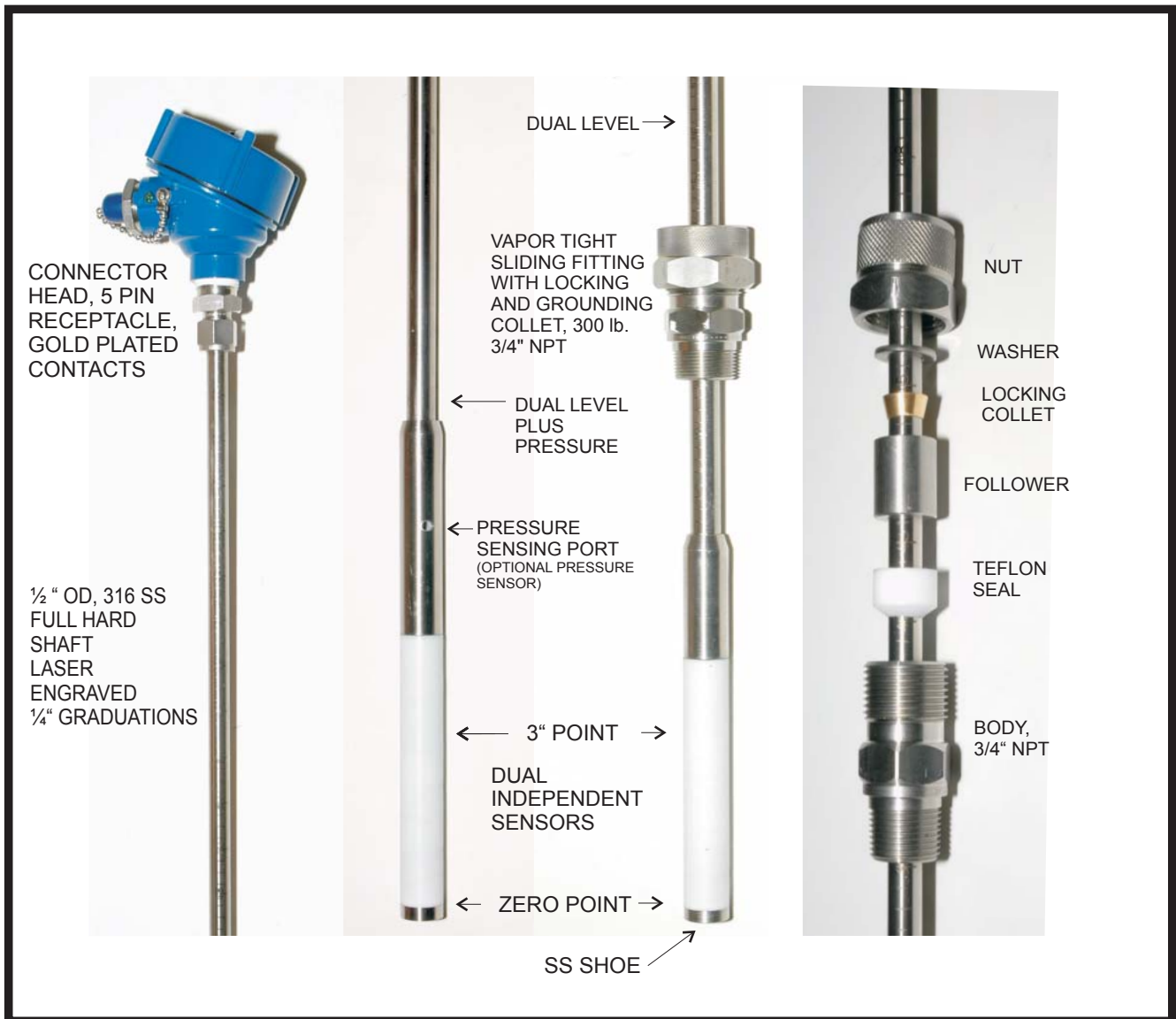

INDUSTRIAL FLUID CONTROLS CINCINNATI, OHIO 45246
(513) 874-8499



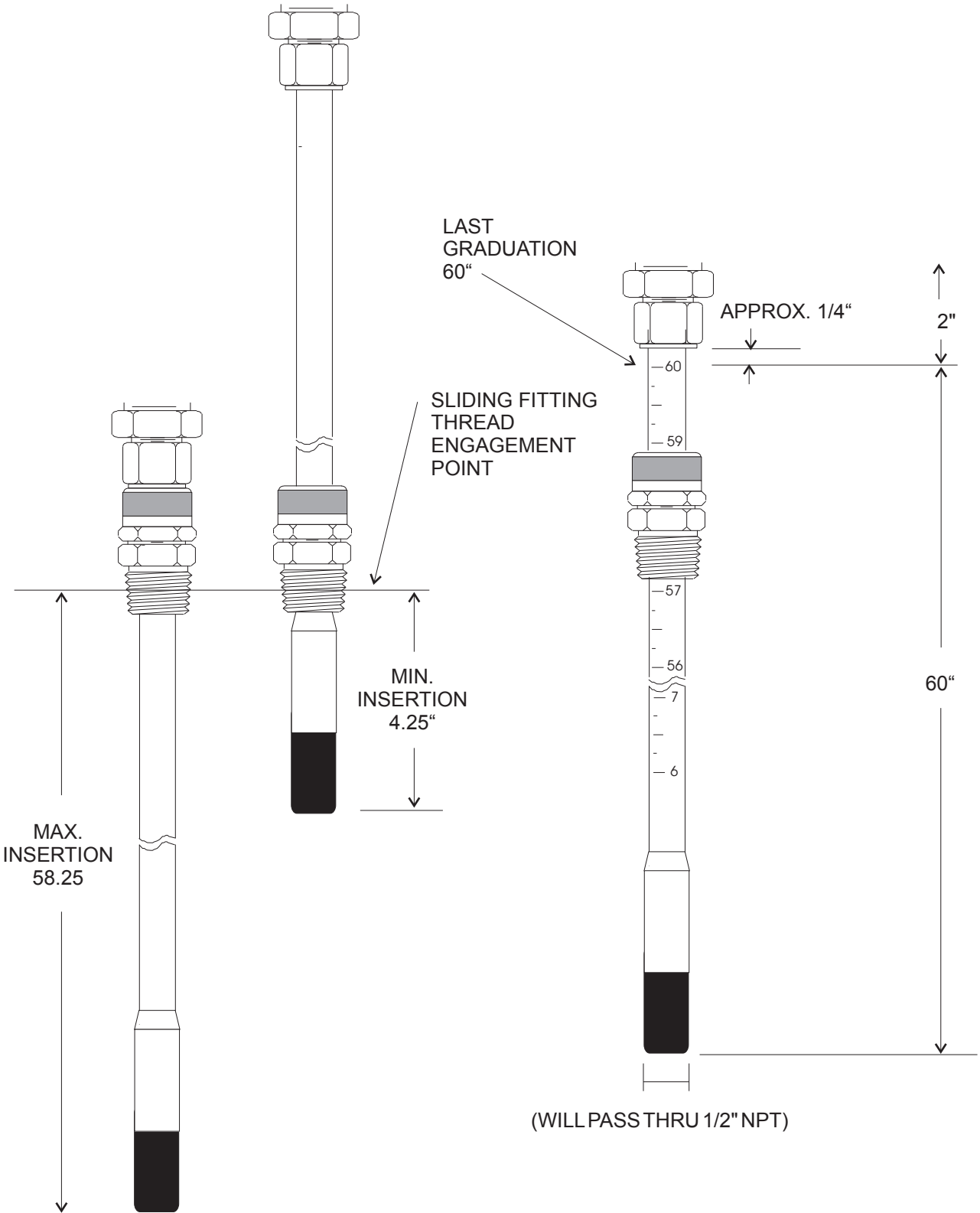

INDUSTRIAL FLUID CONTROLS
 CINCINNATI, OHIO 45246
 (513) 874-8499



JOSEPH SHEFSKY, P.E.

02/23/09

MODEL A-200 LEVEL PROBE, CAPACITANCE SENSOR
 MAX AND MIN INSERTION LENGTH FOR 60" PROBE

DRAWING

SK-02/23/09-2

SPECIAL CONDUCTIVITY PROBE FOR LATEX APPLICATION

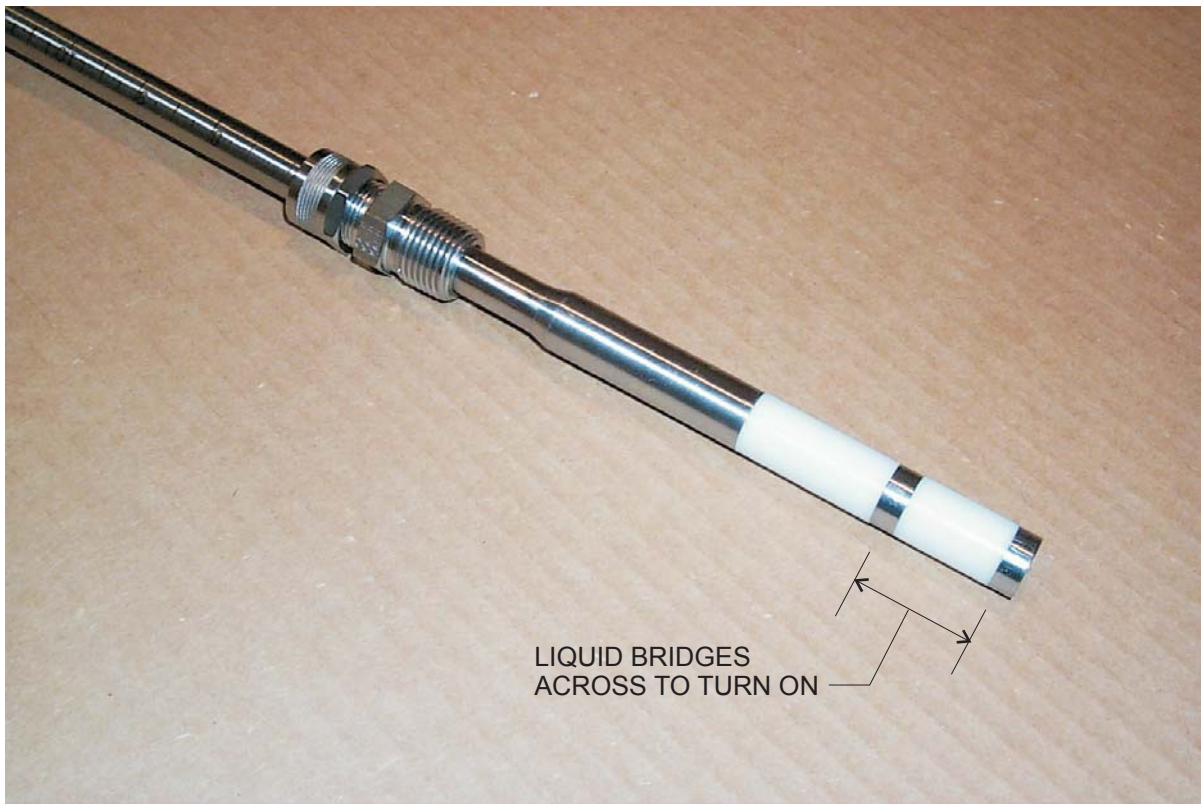

SINGLE POINT CAPACITANCE PROBE WITH PRESSURE SWITCH AND TANK TRUCK SWIVEL ADAPTER WITH 1-1/4" VENT CONNECTION AND LOCATING TAB FOR CLOSED DOME LOADING



PROBE CONNECTOR HEAD

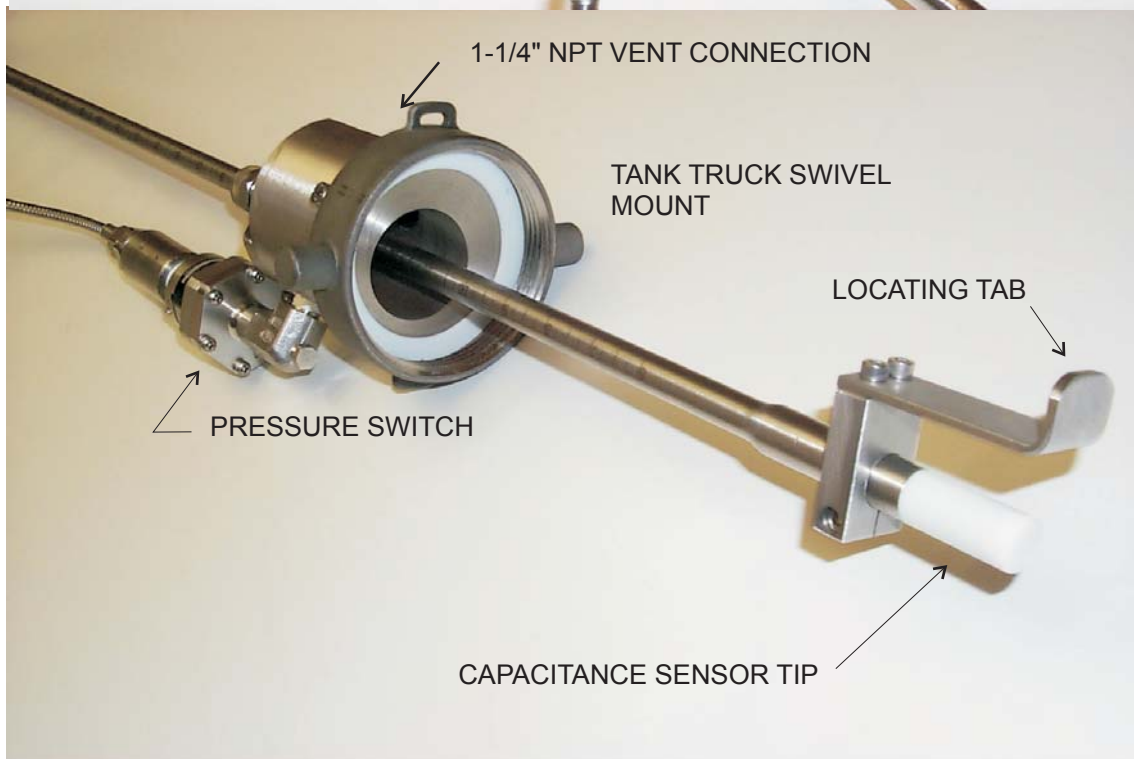

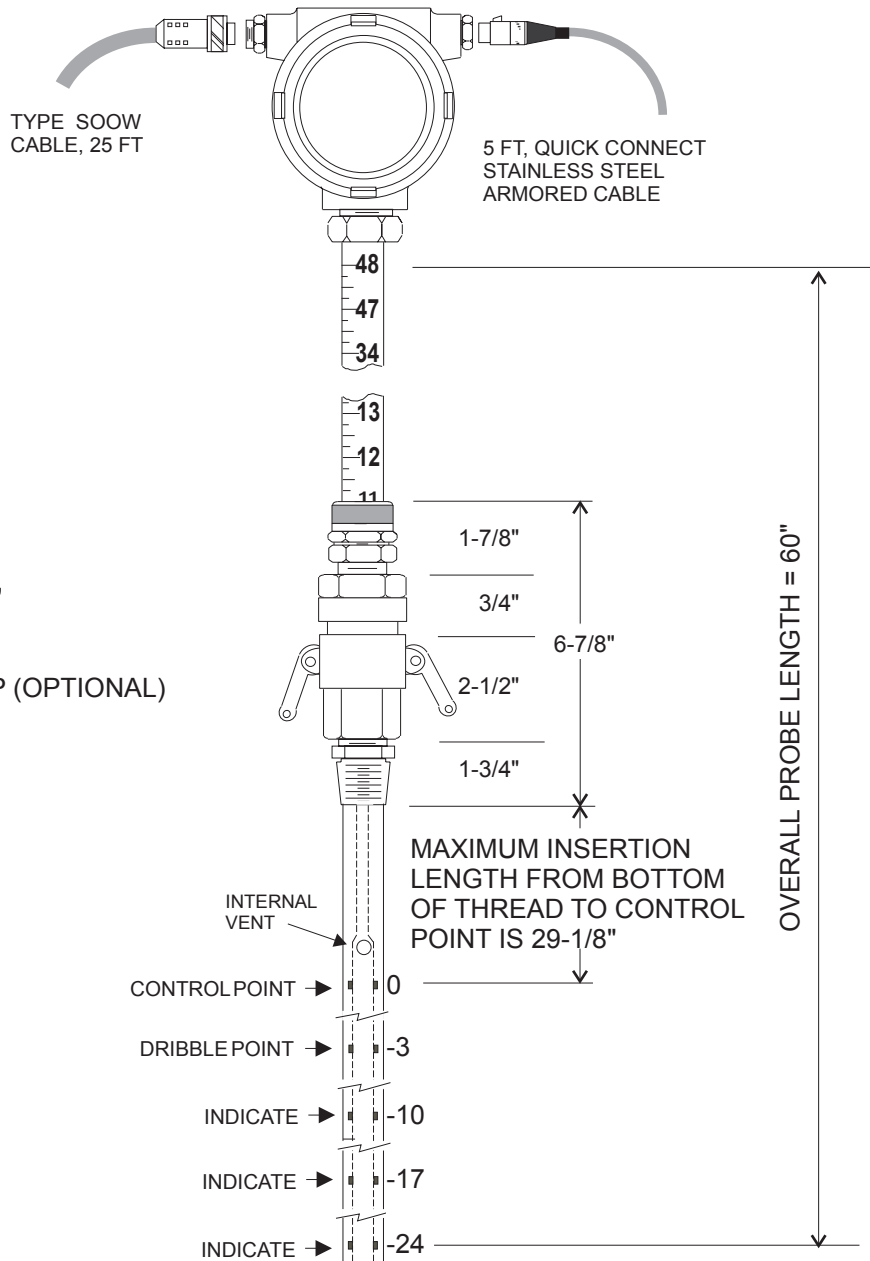

1. INDICATE -24, -17, -10"
2. DRIBBLE AT -3"
3. TRIP AT 0"
4. HIGH PRESSURE TRIP (OPTIONAL)
5. TILT INTERLOCK

PRIMARY PROBE FOR
TWO PROBE SYSTEM



INDUSTRIAL FLUID CONTROLS
CINCINNATI, OHIO 45246
(513) 874-8499



JOSEPH SHEFSKY, P.E.

10/02/07

5-POINT TUBE-INTUBE ULTRASONIC PROBE

DRAWING NO.

100207-2

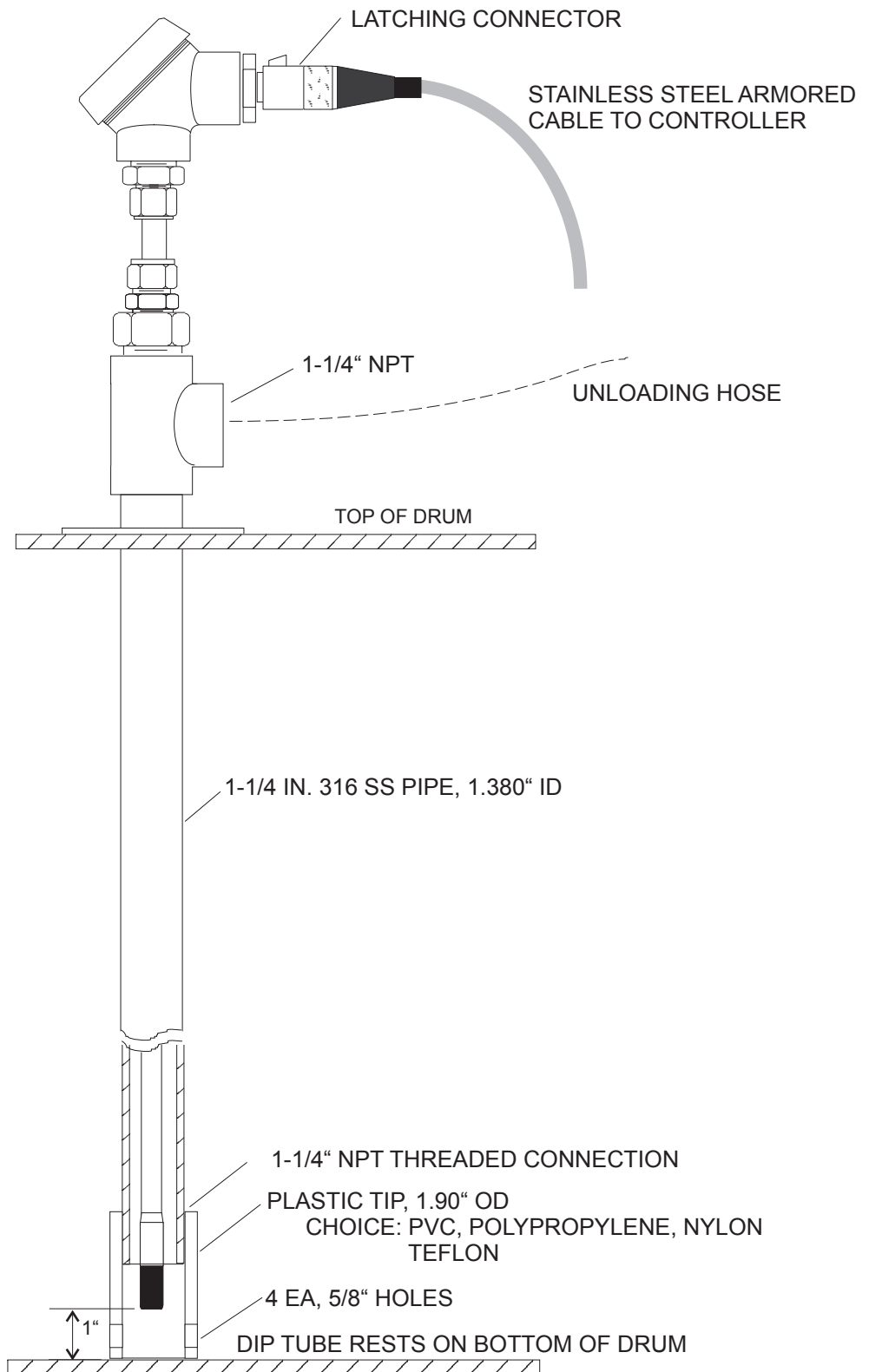

INDUSTRIAL FLUID CONTROLS
CINCINNATI, OHIO 45246
(513) 874-8499

JOSEPH SHEFSKY, P.E.

8/14/03

PROBE/DIP TUBE ASSEMBLY FOR TRIPPING PUMP
WHEN DRUM GOES EMPTY..

DRAWING N

SK-081404-1



SPILLGUARD™

REDUNDANT LIQUID LEVEL ALARM



MODEL B-100F

The **MODEL B-100F SPILLGUARD™** adds affordable redundant high level alarm to existing continuous level controls ■ ■ ■ ■ **Low installed cost, requires no external power or additional wiring to the control room.**

APPLICATION

The Model B-100F SPILLGUARD™ is the perfect companion for existing liquid level instrumentation. This novel instrument provides totally independent and redundant high level sensing and alarming for existing 4 - 20 MA analog level indication and control loops.

OPERATION

The Model B-100F SPILLGUARD™ employs a variable insertion length (up to 5 ft. standard) float sensor probe and installs onto the vessel via 3" 150 lb flange. In most cases the sensor can be installed onto the vessel through an existing roof nozzle. Electrically it is wired directly in parallel with the existing level transmitter (two wires). During normal operation while the liquid level is below the sensor, the existing transmitter functions normally. However, when the liquid reaches the sensor, the loop current pegs upscale, regardless of the transmitter reading. Thus, high level alarming is retained even if the transmitter fails to read the correct liquid level, for example; due to a plugged lead, liquid in the low pressure lead, change in product specific gravity, or general failure of the transmitter. Self-test feature provided to test operation without raising level to activation point or removing probe from tank.

SPECIFICATIONS

- Hermetically sealed reed switch element activated magnetically by float.
- Activation point repeatability +/- 1/4".
- Works with all 4-20 MA transmitters.
- Minimum specific gravity 0.65
- Wetted materials 316 SS, Teflon. Other materials available.
- Insertion length 4" to 60" adjustable, longer lengths available.
- Maximum temperature 400 deg F.
- Pressure rating - standard unit 50 psig. Consult factory for applications up to to 300 psig.

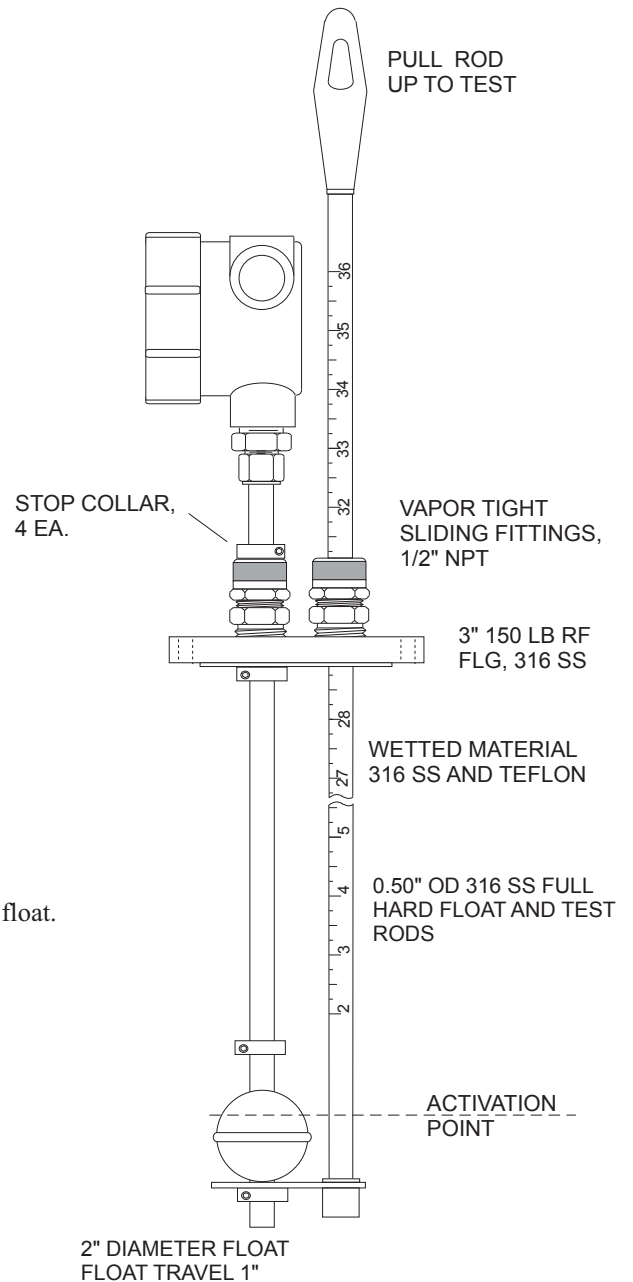

www.adscontrols.com



INDUSTRIAL FLUID CONTROLS CINCINNATI, OHIO 45246
(513) 874-8499



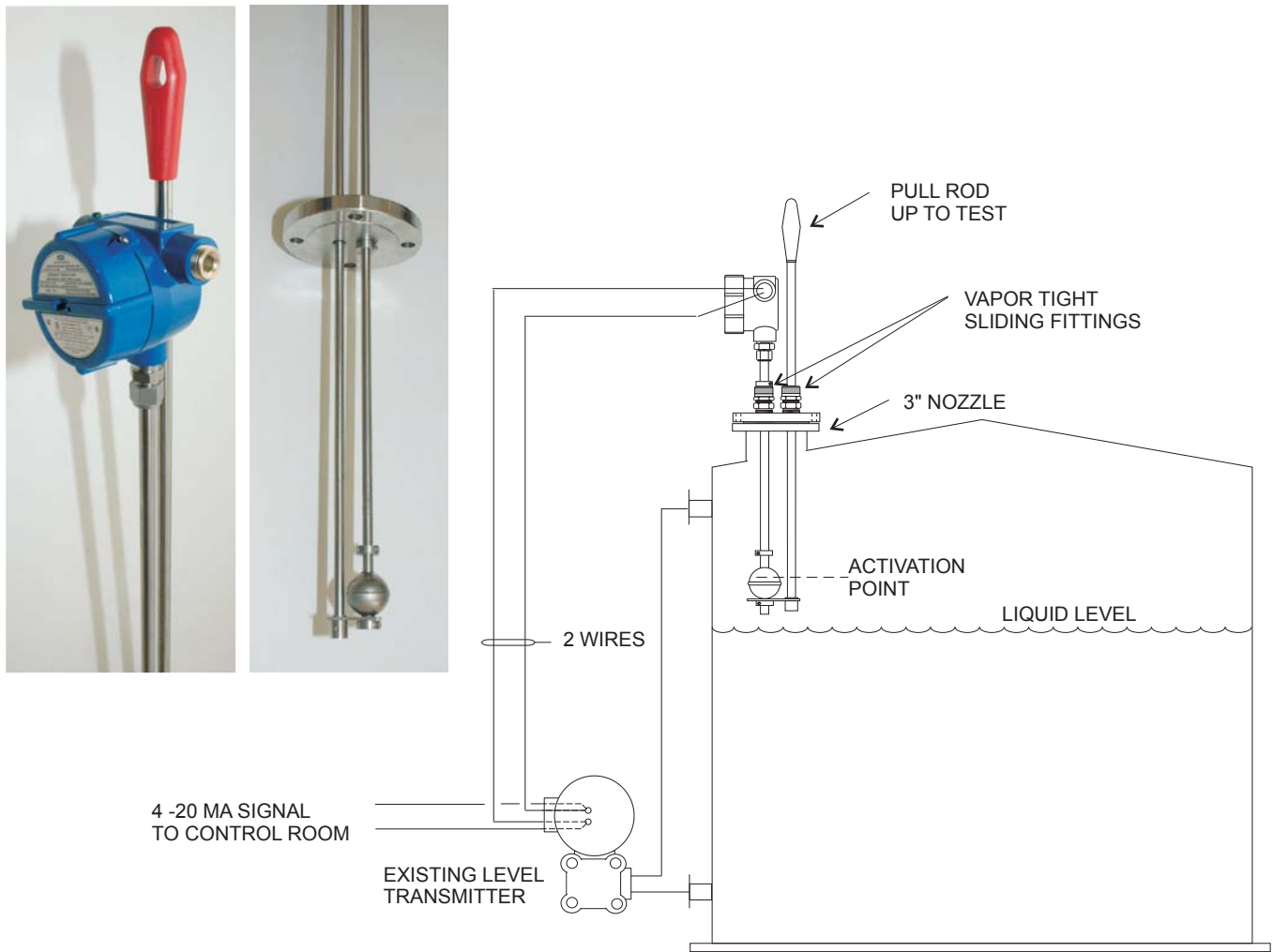

Figure 1. Typical installation with dp type level transmitter. The Model B-100F *Spillguard*[™] can work in conjunction with any continuous liquid level instrument that outputs a 4-20 ma analog signal.

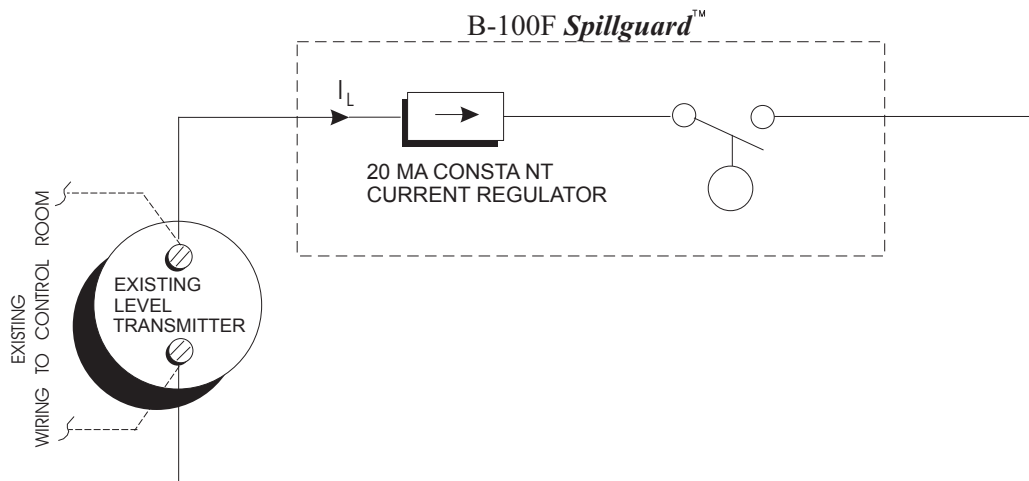
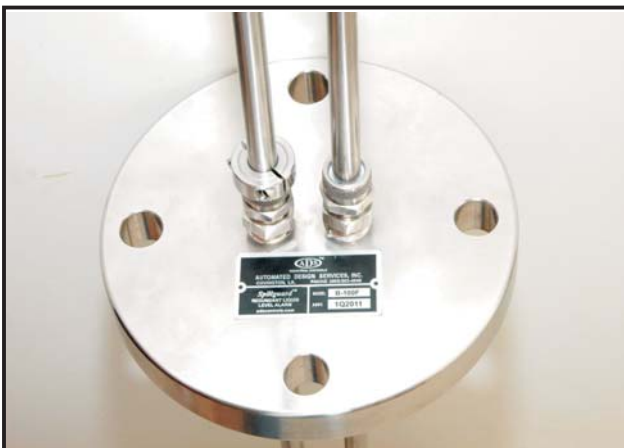

Figure 2. During normal operation the float switch is open and no current flows through the loop. When the level reaches the activation point the float switch closes, adding a constant 20 ma to the loop current. This pegs the loop current upscale regardless of the reading of the primary transmitter, thus providing the backup high level alarm.

CINCINNATI, OHIO 45246 (513) 874-8499

dixonvalve.com



Spillguard™ MODEL B-100F REDUNDANT LIQUID LEVEL ALARM

INDUSTRIAL FLUID CONTROLS

CINCINNATI, OHIO 45246 (513) 874-8499

dixonvalve.com

ACCESSORIES



Manufacturers of liquid level controls for overflow prevention.

- **Liquid terminal automation**
- **Field storage**

LOCATING TAB FOR SETTING OUTAGE CLOSED DOME

TO SET OUTAGE:

1. SCREW NOZZLE ADAPTER ONTO W/O NOZZLE.
2. WITHDRAW GAGE ROD UNTIL TAB TOUCHES INSIDE SHELL OF TANK. NOTE READING ON ROD.
3. ADD DESIRED OUTAGE TO READING AND PUSH DOWN ROD TO THE CALCULATED READING.
4. THE PROBE SENSOR IS NOW AT THE DESIRED OUTAGE.

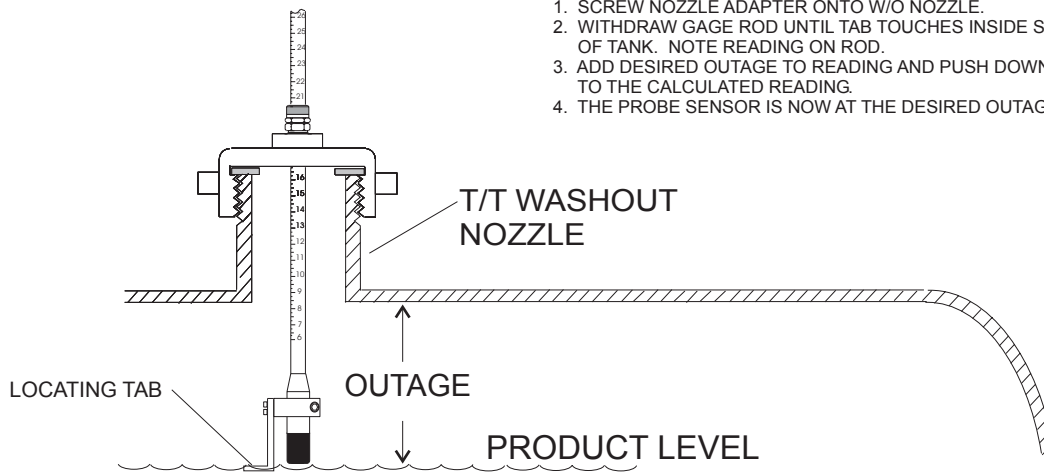

EXAMPLE SETTING 10" OUTAGE:

ROD WITHDRAWN
READING 12.5"

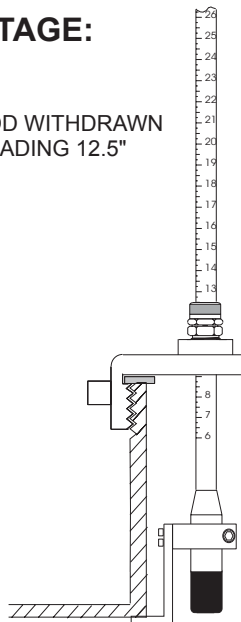

ADD 10" TO READING
(12.5 + 10 = 22.5")
PUSH ROD DOWN TO 22.5"
READING 22.5"

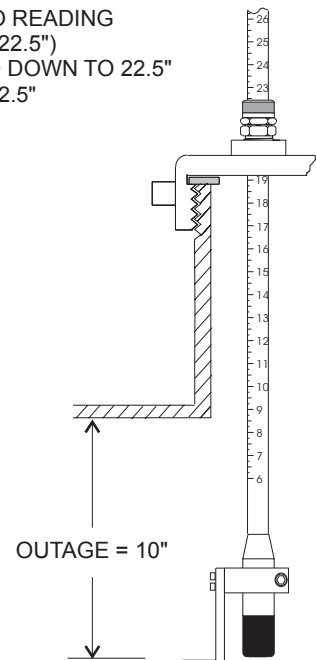

INDUSTRIAL FLUID CONTROLS CINCINNATI, OHIO 45246
(513) 874-8499



The Right Connection®

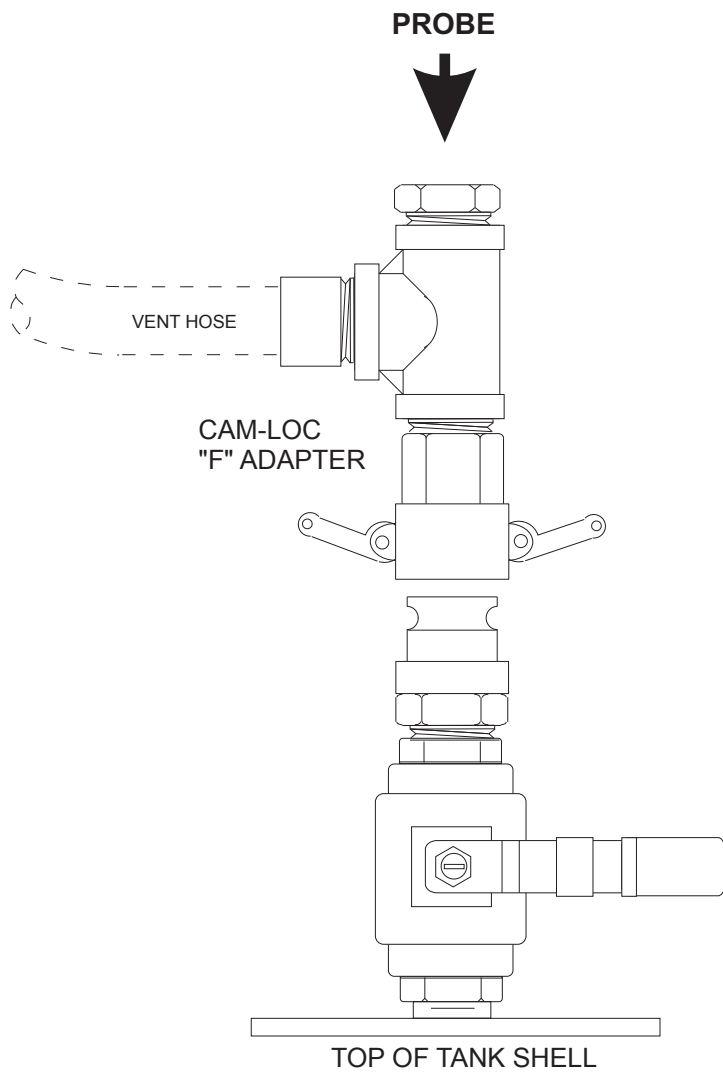

WITH VENT

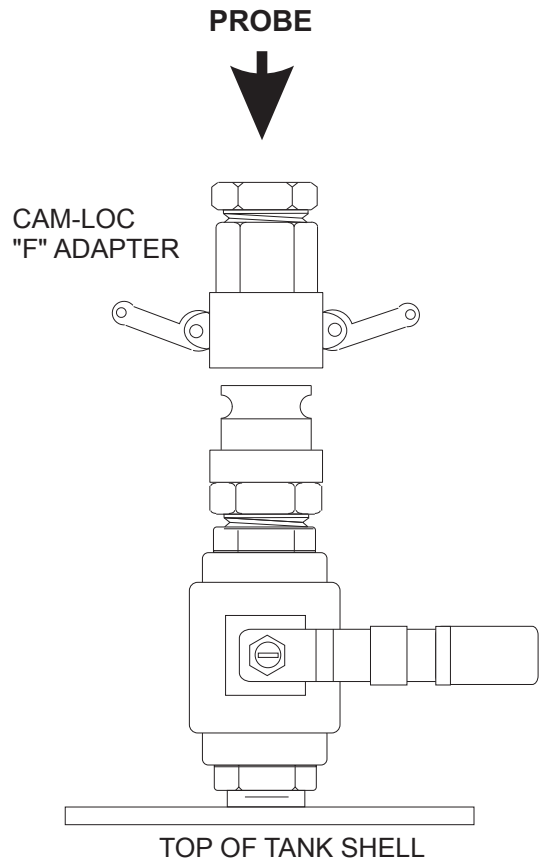

WITHOUT VENT



INDUSTRIAL FLUID CONTROLS
CINCINNATI, OHIO 45246
(513) 874-8499



JOSEPH SHEFSKY, P.E.

11/11/13

SPECIAL FITTING

DRAWING NO.

SK-111113-11

OUTGAGE™

STAINLESS STEEL OUTGAGE GAGE

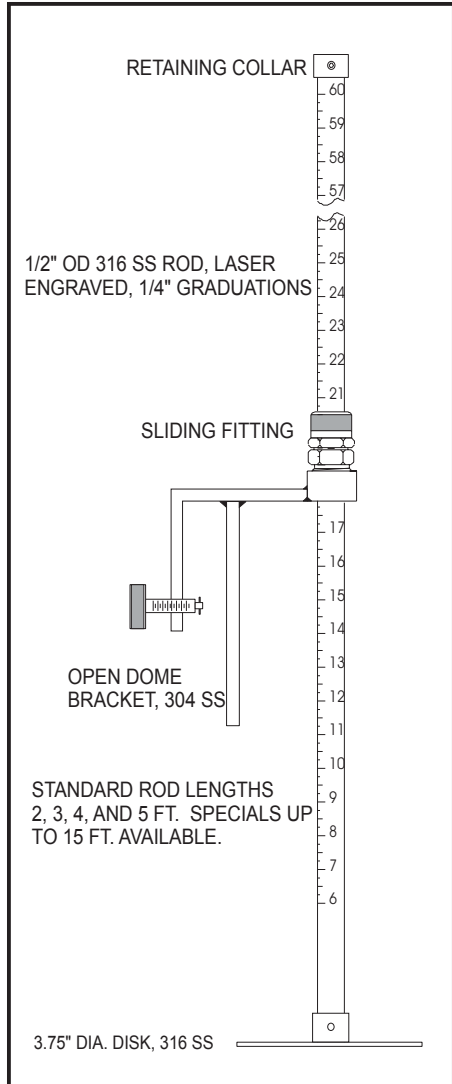

TO SET OUTGAGE:

1. CLAMP BRACKET TO VERTICAL SECTION OF DOME.
2. WITHDRAW GAGE ROD UNTIL DISK TOUCHES INSIDE SHELL OF TANK. NOTE READING ON ROD.
3. ADD DESIRED OUTGAGE TO READING AND PUSH DOWN ROD TO THE CALCULATED READING.
4. THE DISK IS NOW AT THE DESIRED OUTGAGE.

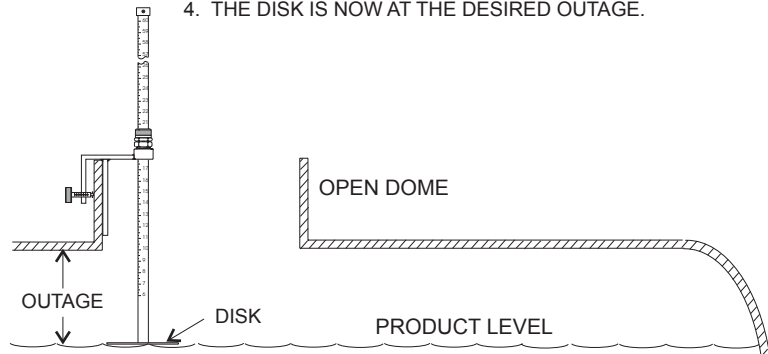

EXAMPLE SETTING 10" OUTGAGE:

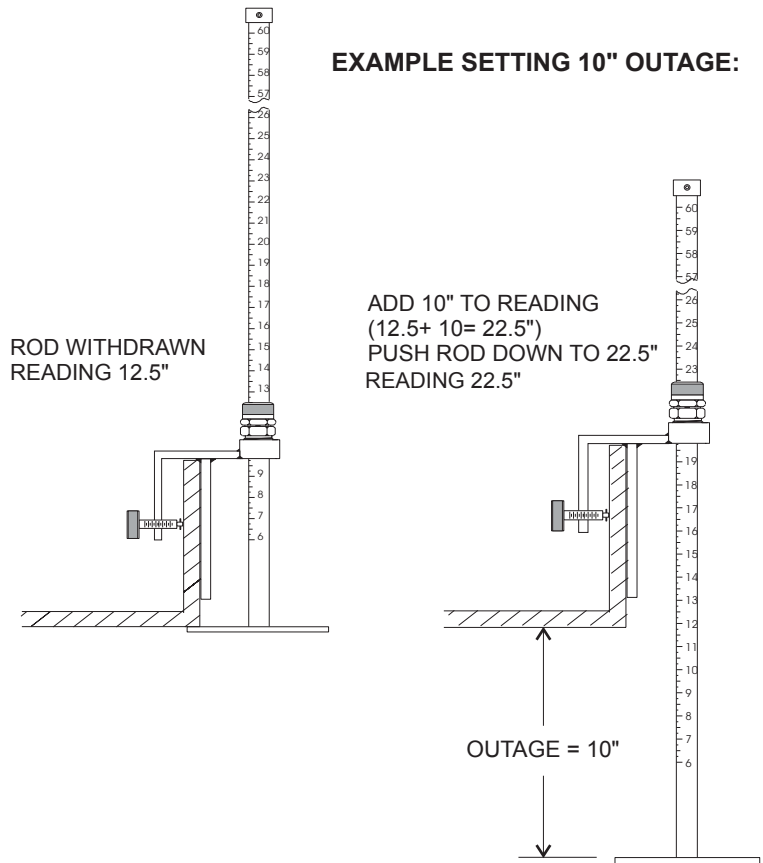

INDUSTRIAL FLUID CONTROLS CINCINNATI, OHIO 45246
(513) 874-8499



ACCESSORIES

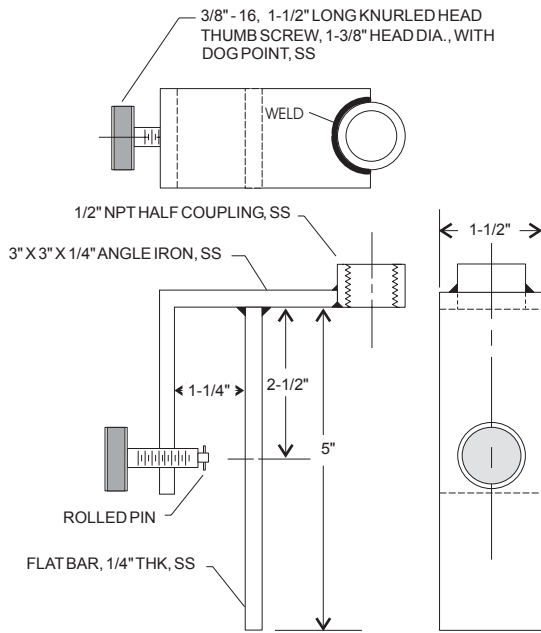

OPEN DOME LOADING ADAPTER BRACKET FOR OUTALARM AND SPILLGUARD LEVEL PROBES

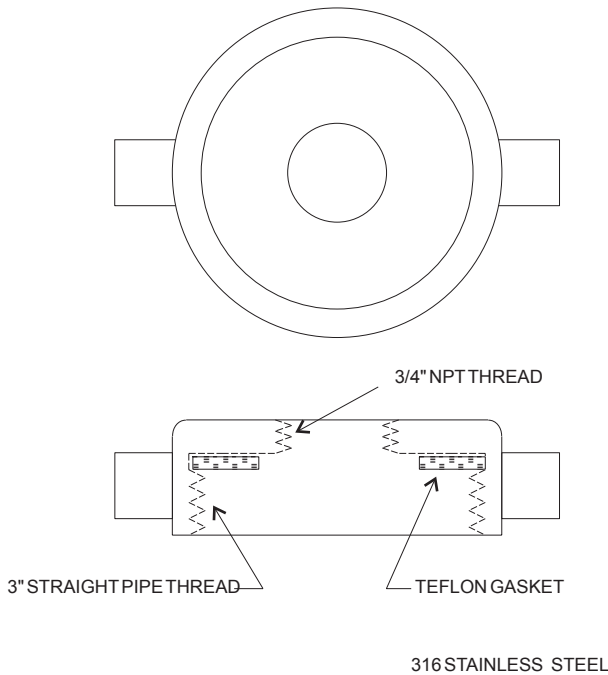

TANK TRUCK 3" WASH-OUT NOZZLE ADAPTER FOR OUTALARM AND SPILLGUARD LEVEL PROBES

ACCESSORIES



SHIELD IN PLACE



SHIELD PUSHED UP
FOR CLEANING

- SOLID TEFLON CONSTRUCTION
- REQUIRES 1" NPT PROCESS CONNECTION
- CAN SLIDE UP FOR CLEANING PROBE
- ALLOWS FULL IMPINGEMENT OF PRODUCT ONTO SENSOR WITHOUT TRIPPING.

SPLASH SHIELD FOR OUTALARM AND SPILLGUARD LEVEL PROBES

ACCESSORIES



CABLE, STAINLESS STEEL ARMORED
15 FT, 25 FT, 50 FT. STANDARD
OTHER LENGTHS OPTIONAL



CABLE, COILED
RETRACTED - 4 FT.
EXTENDED - 20 FT.

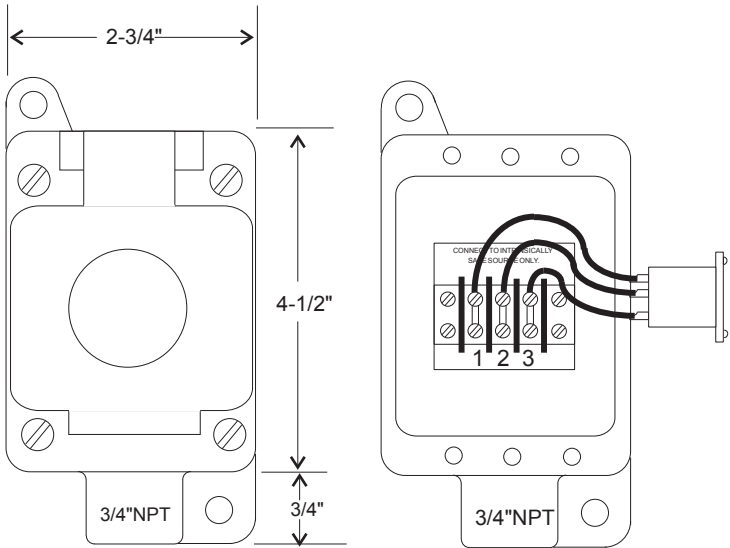

CABLE JUNCTION BOX FOR MODELS A-100 AND A-200

OPTIONAL SO STYLE CABLE WITH SCREW-ON CONNECTORS FOR ADS, INC. SERIES A-100REMOTE, A-200, AND A-300 CONTROLS



SO STYLE RUBBER JACKET CABLE



CABLE CONNECTORS



EXPLOSION PROOF CONTROLLER RECEPTACLE



PROBE RECEPTACLE

OUTGAGE™

STAINLESS STEEL OUTGAGE GAGE

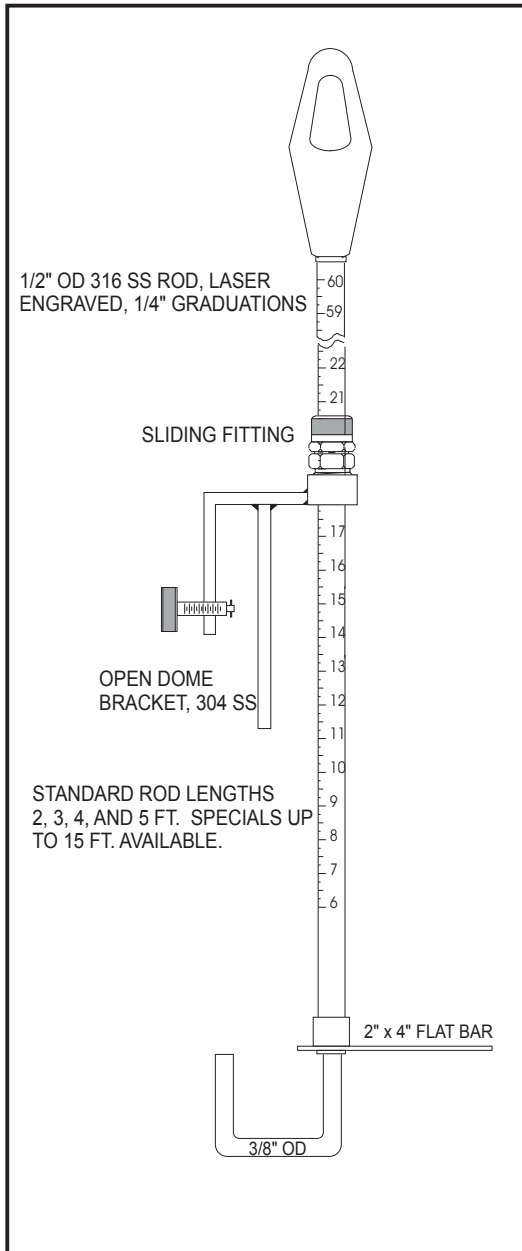

TO SET OUTGAGE:

1. CLAMP BRACKET TO VERTICAL SECTION OF DOME.
2. WITHDRAW GAGE ROD UNTIL U BAR TOUCHES INSIDE SHELL OF TANK. NOTE READING ON ROD.
3. ADD DESIRED OUTGAGE TO READING AND PUSH DOWN ROD TO THE CALCULATED READING.
4. THE FLAT BAR IS NOW AT THE DESIRED OUTGAGE.

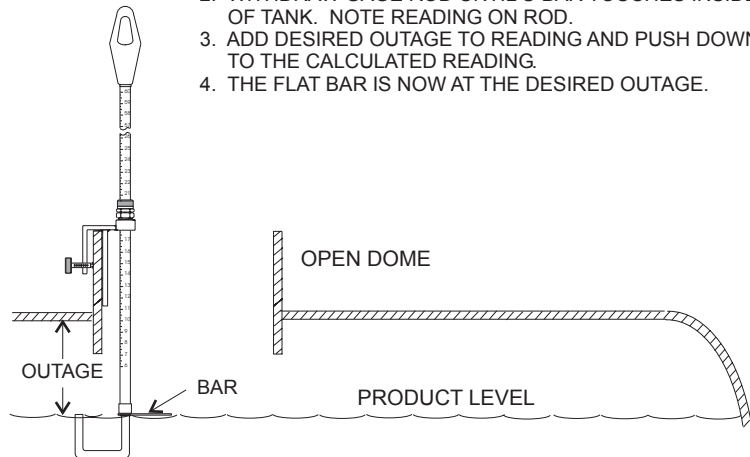

EXAMPLE SETTING 10" OUTGAGE:

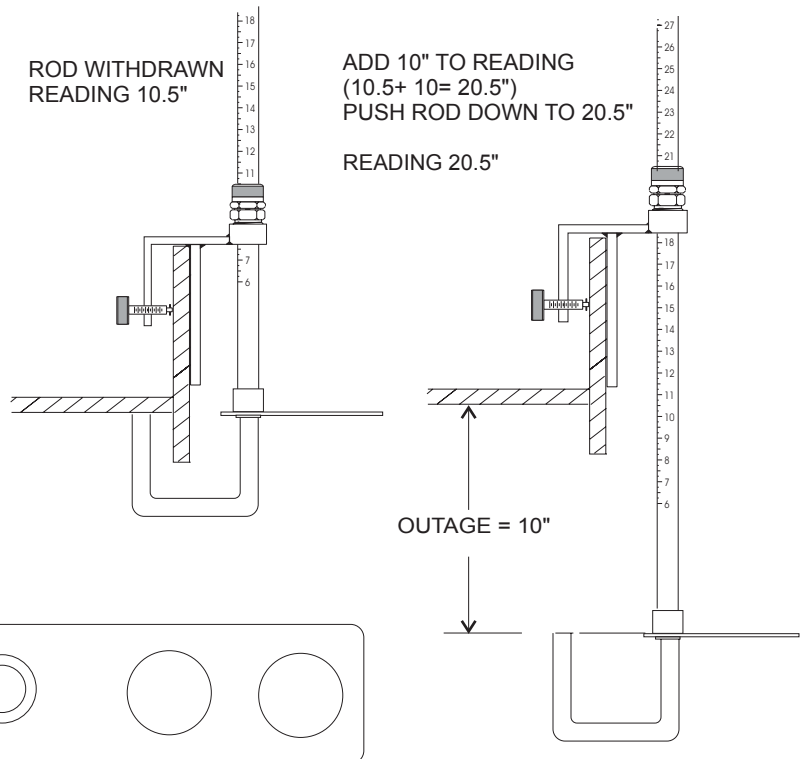

ROD ATTACHMENT POINT

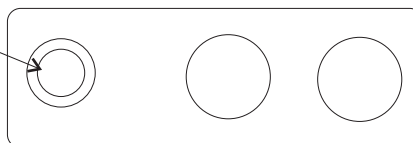

FLAT BAR 2" x 4" x 1/8" WITH 2 EA 7/8" HOLES



INDUSTRIAL FLUID CONTROLS CINCINNATI, OHIO 45246
(513) 874-8499



DRILL 1-3/64" TOP AND BOTTOM

GLUE CONNECTIONS

3/4" PVC COUPLING (2 EA.)

3" PVC PIPE CAP (2 EA.)

3" SCH 40 PVC PIPE, 4.5 FT.

3/4" THIN WALL PVC, 5 FT.

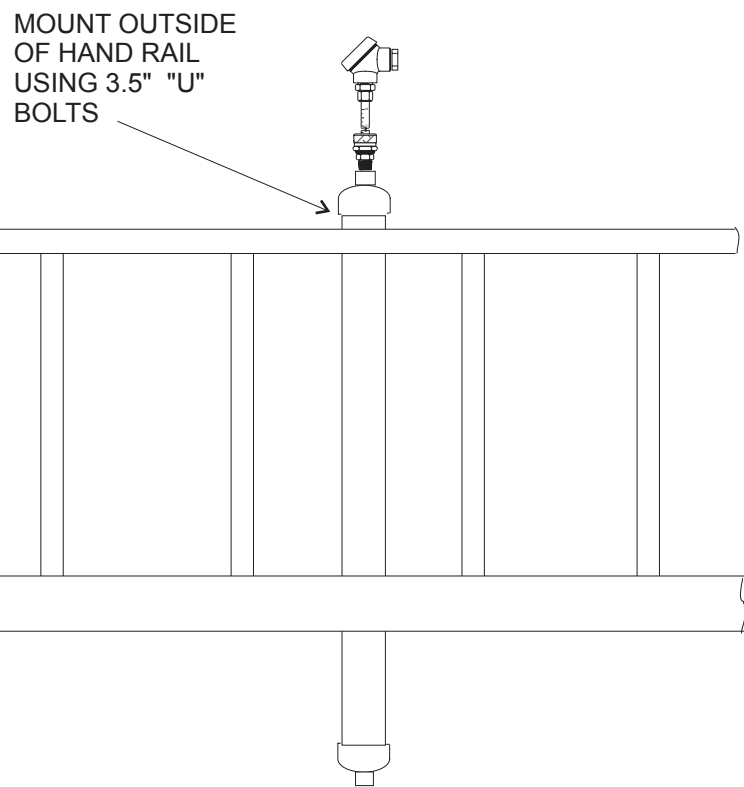
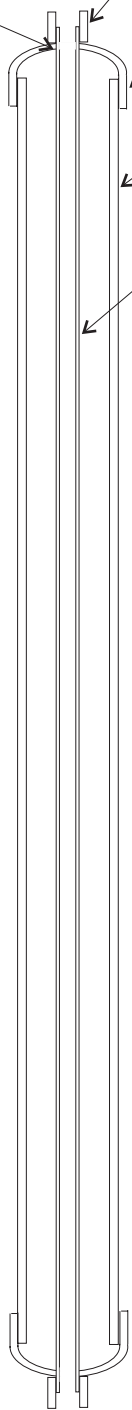

INDUSTRIAL FLUID CONTROLS
 CINCINNATI, OHIO 45246
 (513) 874-8499



JOSEPH SHEFSKY, P.E.

06/11/09

PROPOSED PROBE HOLDER FOR IMTT
 GEISMAR

DRAWING NO.

SK-061109-2

LOCATING TAB FOR SETTING OUTAGE, OPEN DOME

TO SET OUTAGE:

1. CLAMP BRACKET TO VERTICAL SECTION OF DOME OR NOZZLE..
2. WITHDRAW GAGE ROD UNTIL TAB TOUCHES INSIDE SHELL OF TANK. NOTE READING ON ROD.
3. ADD DESIRED OUTAGE TO READING AND PUSH DOWN ROD TO THE CALCULATED READING.
4. THE PROBE SENSOR IS NOW AT THE DESIRED OUTAGE.

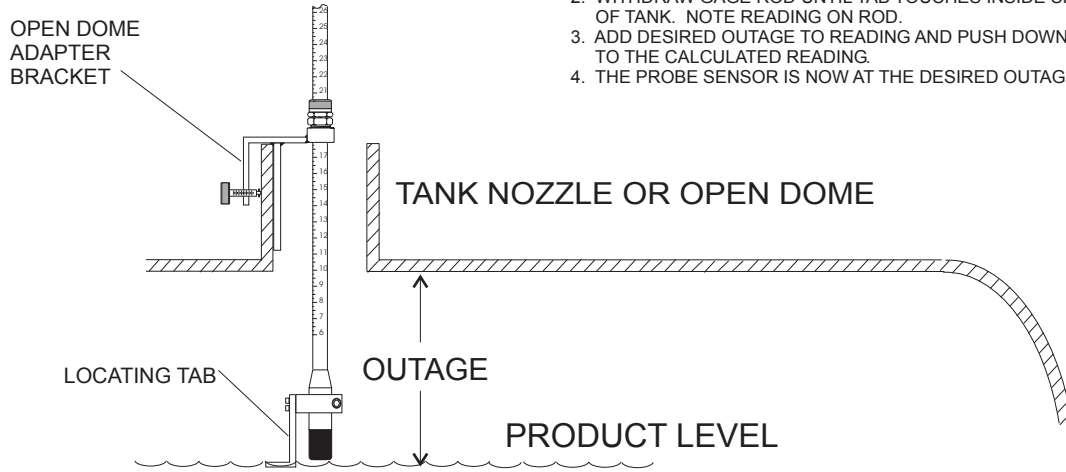

EXAMPLE SETTING 10" OUTAGE:



ROD WITHDRAWN
READING 12.5"

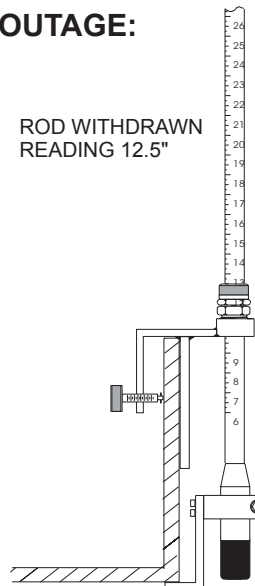

ADD 10" TO READING
(12.5 + 10 = 22.5")
PUSH ROD DOWN TO 22.5"
READING 22.5"

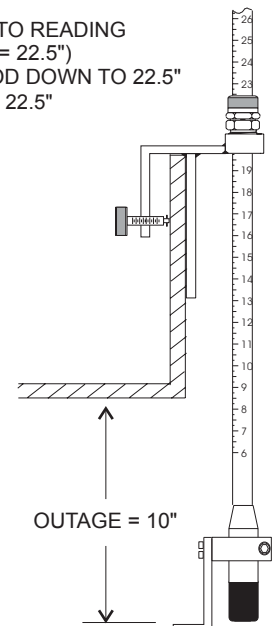

INDUSTRIAL FLUID CONTROLS CINCINNATI, OHIO 45246
(513) 874-8499



ACCESSORIES

HIGH PRESSURE FITTING, MAX PRESSURE 150 LB



ASSEMBLED

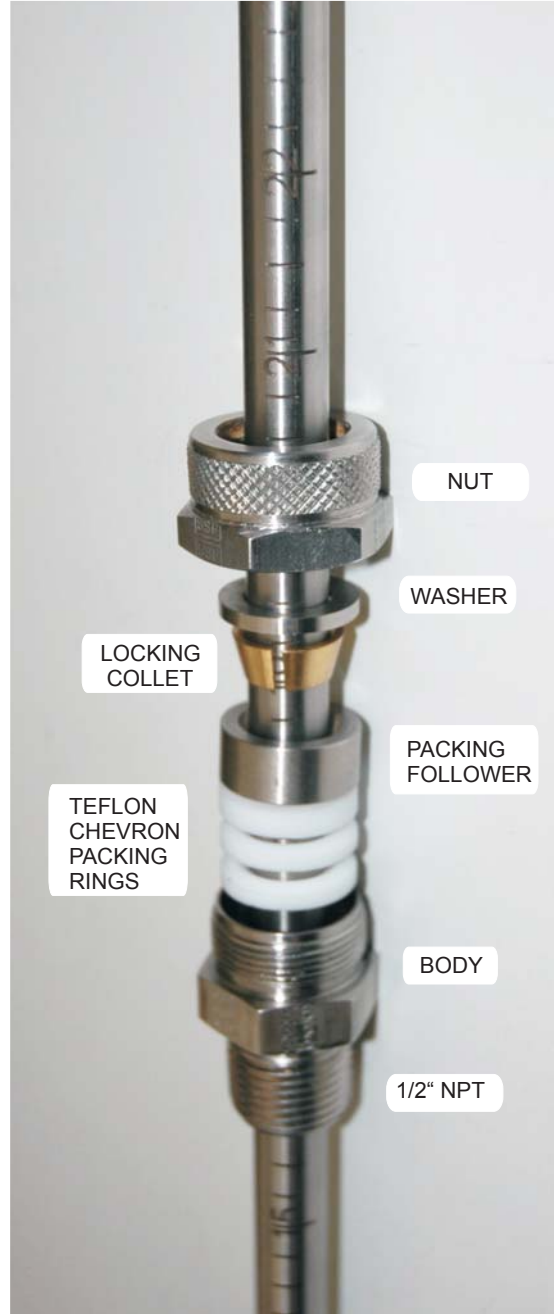

EXPLODED VIEW

INDUSTRIAL FLUID CONTROLS CINCINNATI, OHIO 45246
(513) 874-8499

ACCESSORIES

HIGH PRESSURE FITTING, MAX PRESSURE 300 LB



ASSEMBLED



EXPLODED VIEW

ACCESSORIES

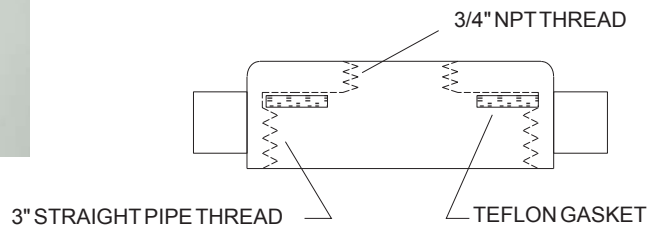
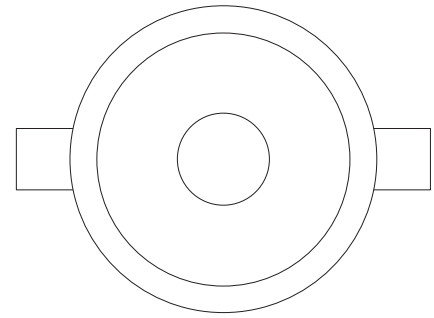

316 STAINLESS STEEL

TANK TRUCK WASHOUT NOZZLE ADAPTER DRILLED AND TAPPED 3/4" NPT

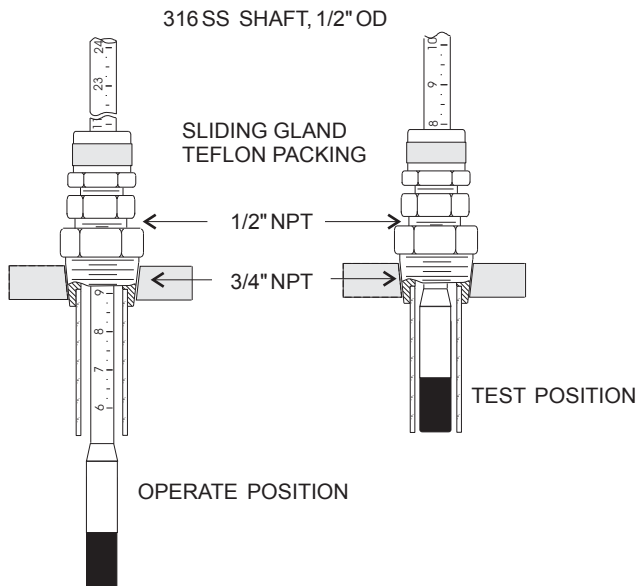

SELF TEST ADAPTER FOR OUTALARM AND SPILLGUARD LEVEL PROBES

ACCESSORIES

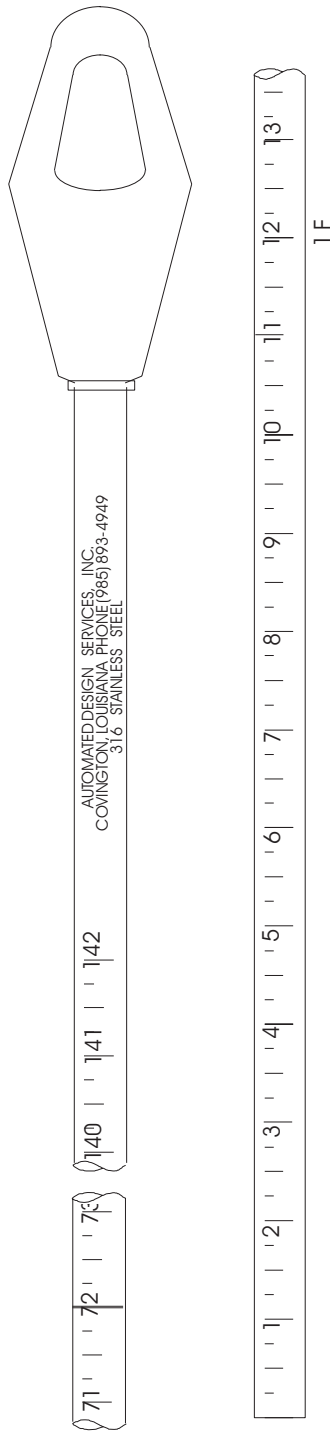

SPECIFICATIONS:

- 1/2" x 0.065 WT, HARDENED 316 STAINLESS STEEL
- LASER ENGRAVED SCALE WITH 1/4" GRADUATIONS
- RODS COME IN TWO SECTIONS THAT SCREW TOGETHER AT THE MIDPOINT
- FOOT MARKS INSCRIBED ON ROD AT 1 FOOT INTERVALS BELOW INCH MARK
- HEAVY DUTY PLASTIC HANDLE
- OPTIONAL SLIDING INNAGE BAR

ASSEMBLY:

1. THE TWO SECTIONS OF THE GAGE ROD ARE A MATCHED PAIR AND ARE PACKAGED TOGETHER TO PRESERVE THE ALIGNMENT OF THE ENGRAVING. TO ASSEMBLE, SCREW THE SECTIONS TOGETHER.
2. TO PERMANENTLY LOCK THE THREADED CONNECTION USE THE LOCTITE NO. 262 THREAD LOCKER PROVIDED. APPLY A SMALL QUANTITY OF THE THREAD LOCKER TO THE MALE STUD AND SCREW TOGETHER. PLEASE NOTE THAT ONCE THE LOCTITE CURES IT WILL BE IMPOSSIBLE TO DISASSEMBLE THE TWO ROD SECTIONS.



ROD COUPLING



OPTIONAL INNAGE BAR



HANDLE



OPTIONAL END STOP (USED WITH INNAGE BAR)

GAGE ROD, 12 FT. LONG

ACCESSORIES

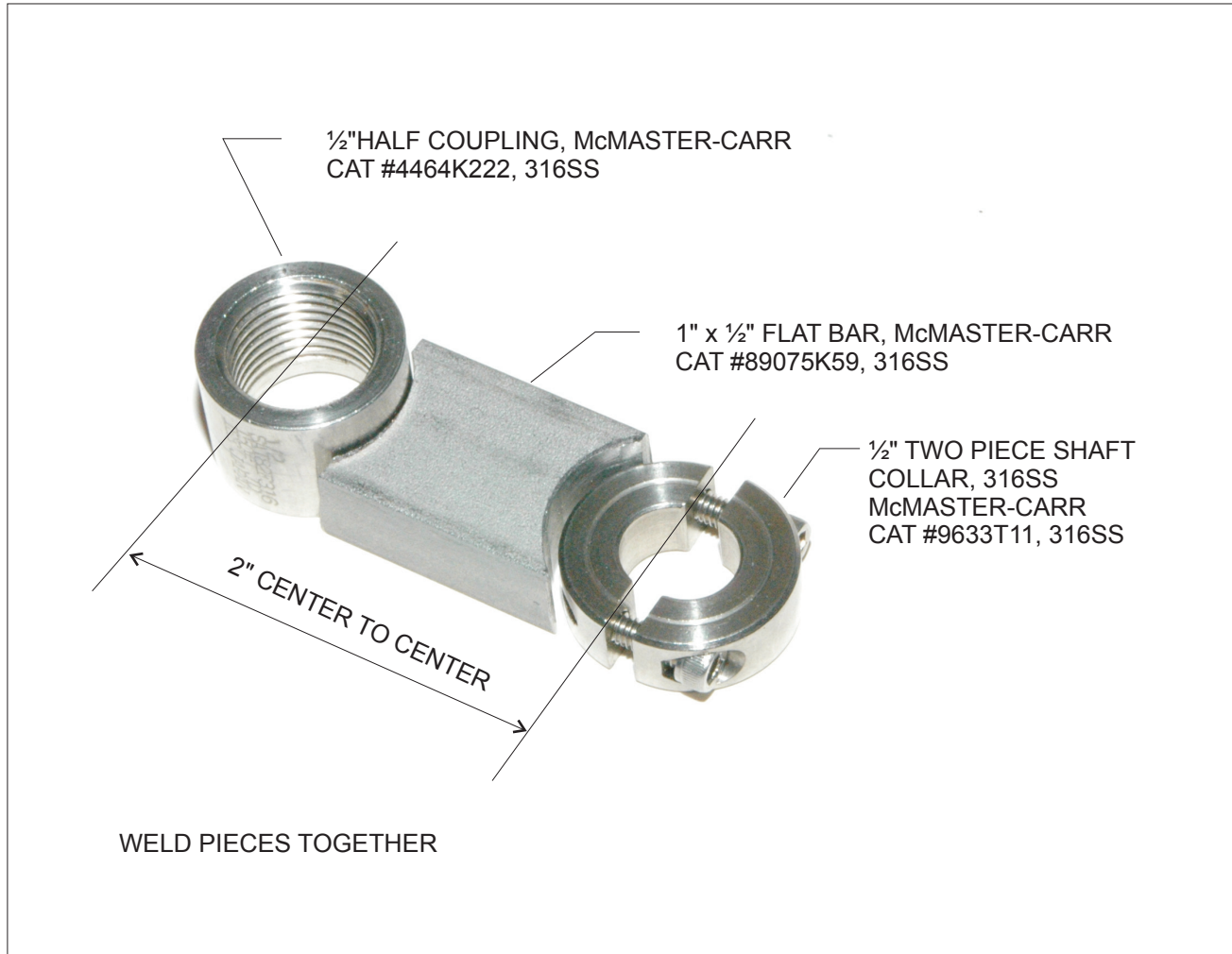

PROPOSED A-100 TO INNAGE GAGE ROD ADAPTER

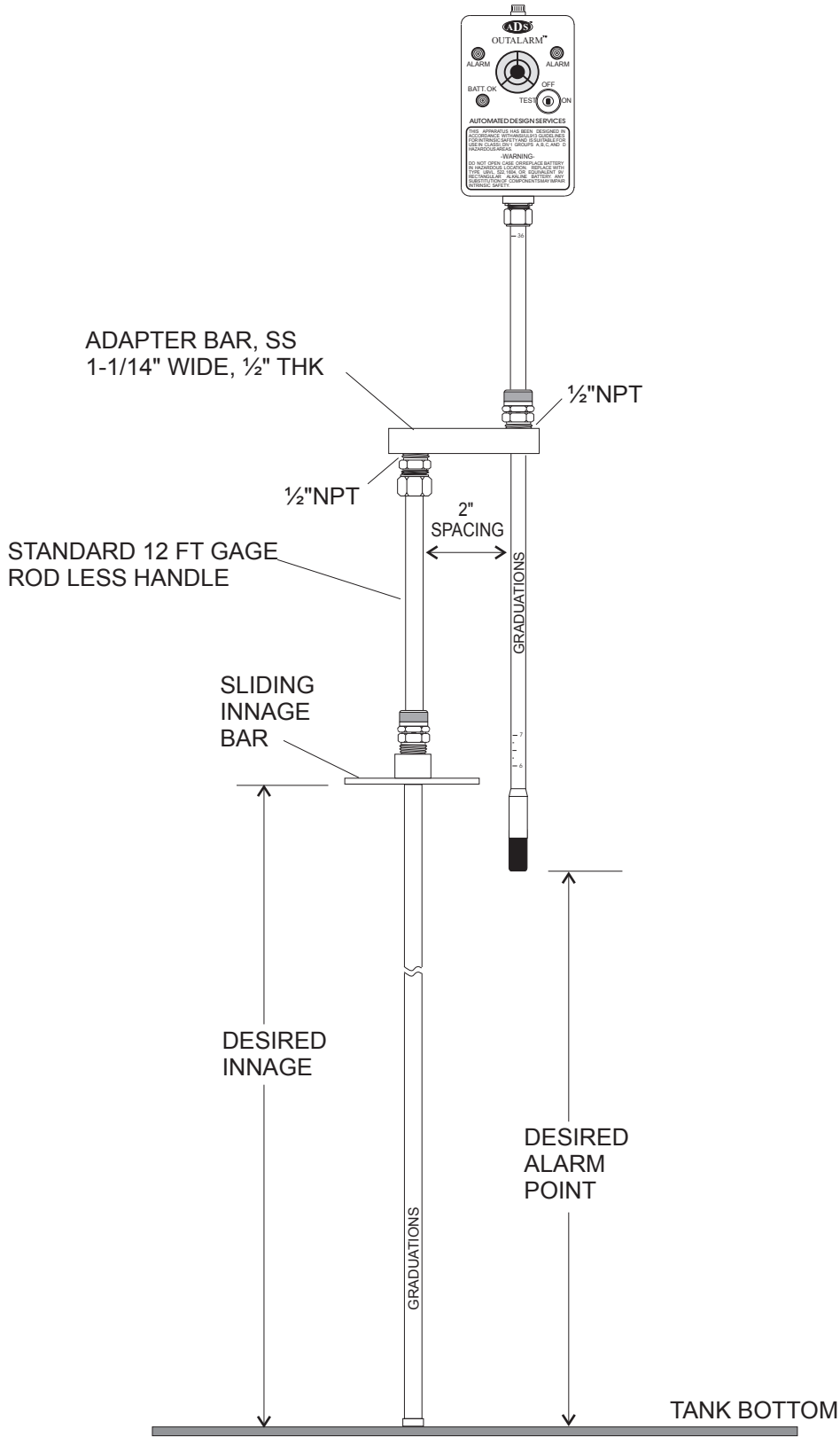

INDUSTRIAL FLUID CONTROLS
 CINCINNATI, OHIO 45246
 (513) 874-8499



JOSEPH SHEFSKY, P.E. 03/11/14

A-100 ADAPTED TO INNAGE GAGE ROD

DRAWING NO.

SK-031114-1

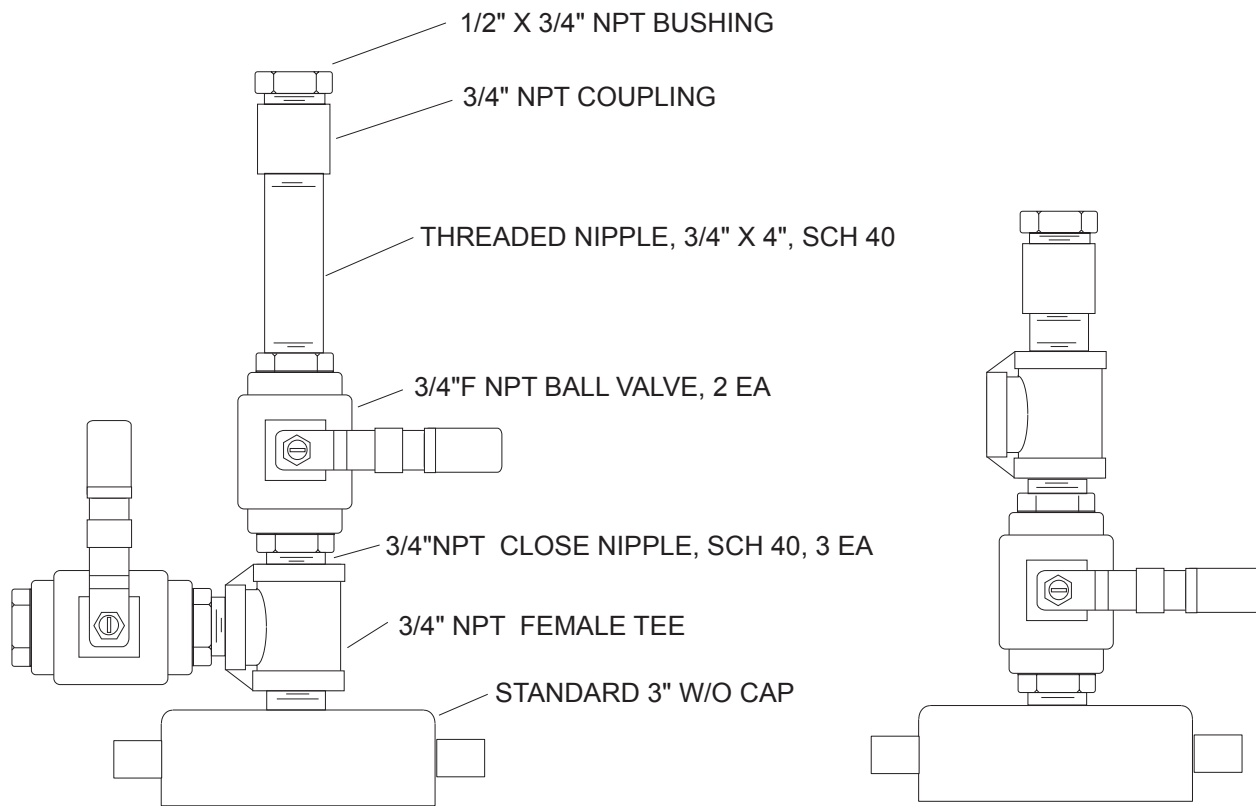

TWO VALVE CONFIGURATION WITH VENT

SINGLE VALVE CONFIGURATION WITH VENT

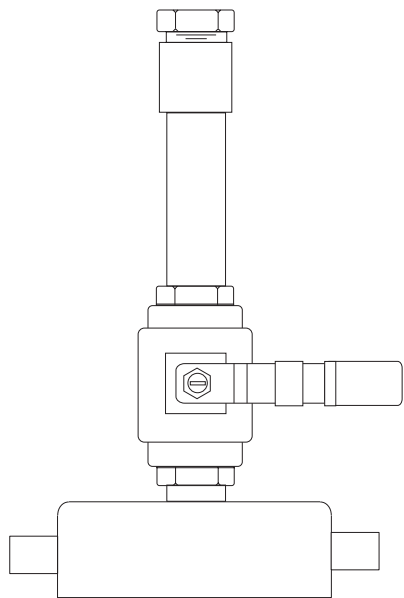

NO VENT CONFIGURATION



W/O CAP DRILLED AND TAPPED 1" NPT

TANK TRUCK 3" WASH-OUT NOZZLE ADAPTER VARIOUS CONFIGURATIONS FOR OUTALARM AND SPILLGUARD LEVEL PROBES

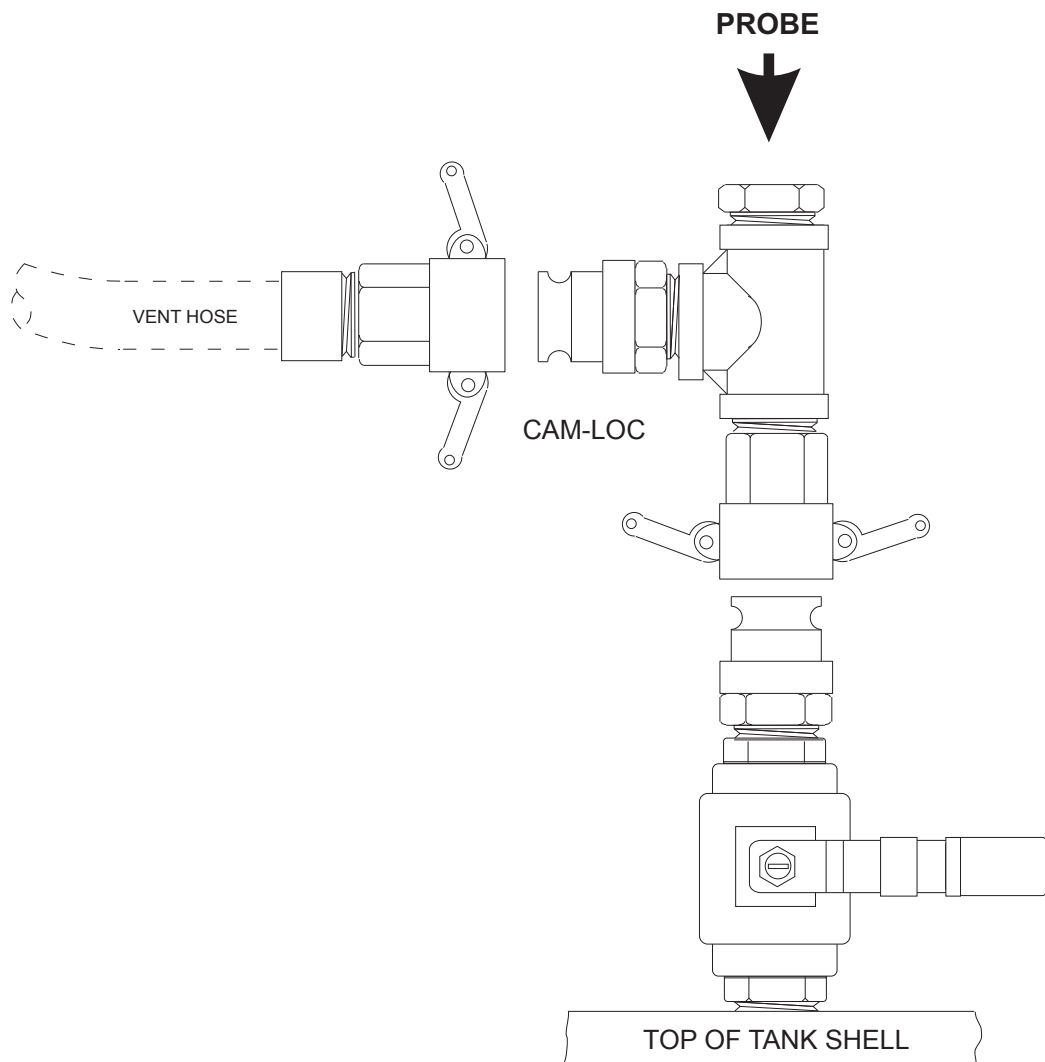

INDUSTRIAL FLUID CONTROLS
 CINCINNATI, OHIO 45246
 (513) 874-8499



JOSEPH SHEFSKY, P.E.

05/14/14

PROBE ADAPTION WITH VENT COLLECTION

DRAWING NO.

SK-051414-1

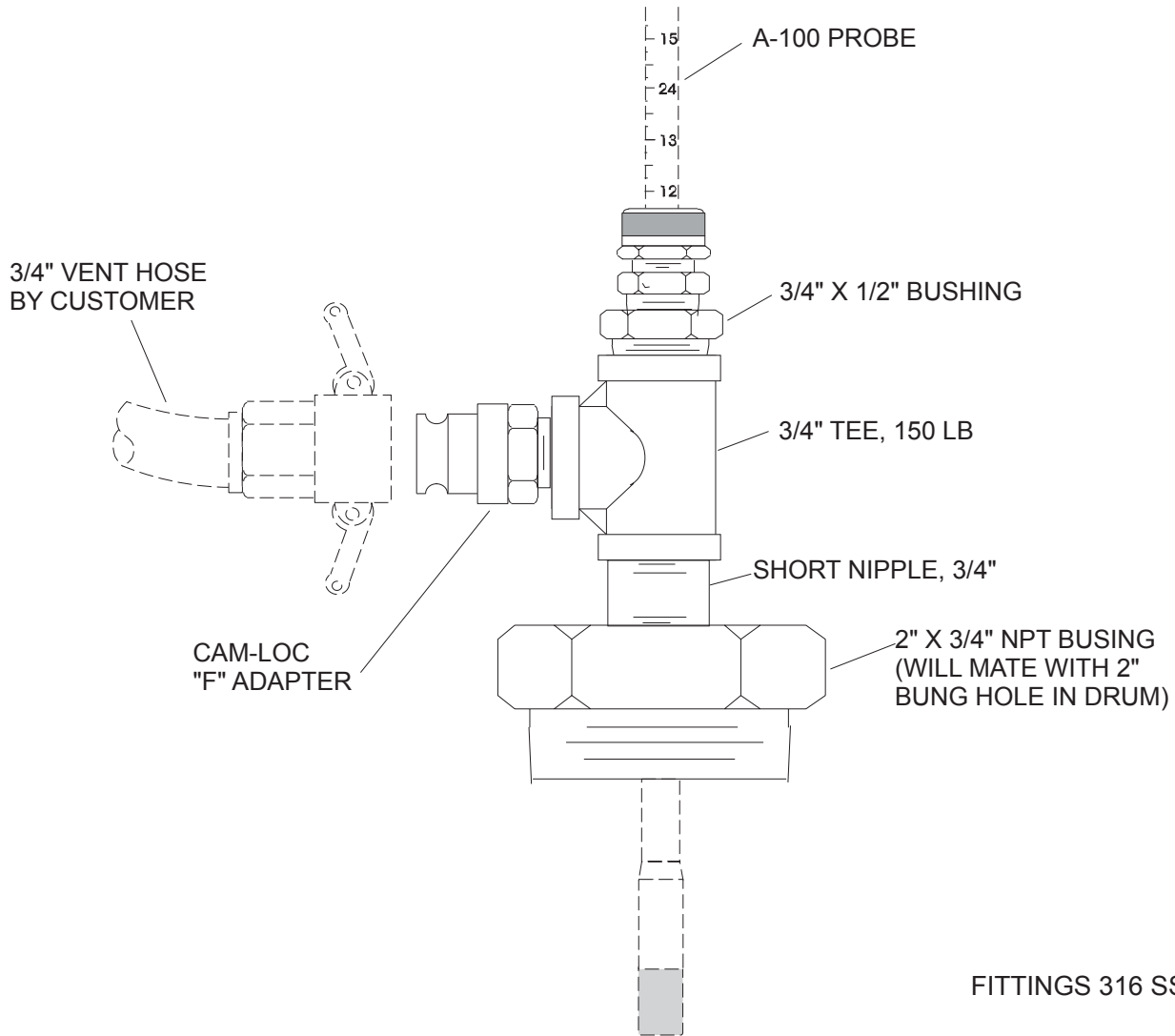

CONNECTION FOR ADAPTING A-100 TO DRUM WITH INTEGRAL VENT